

# TOYOTA INDUSTRIAL VEHICLE

# PARTS CATALOG

FBA10,15 20-FBA10,15  
30-FBA10,15  
No.G208-1

TOYOTA MOTOR CORPORATION  
TOYODA AUTOMATIC LOOM WORKS, LTD.

# TOYOTA

## FORKLIFT TRUCK

### PARTS CATALOG

MODEL	----- F B A -----
FRAME NO.	----- F B A 1 5 -----
LIFTING HEIGHT	----- mm

#### DESCRIPTION

UL-approved Model Type E	
Cold Storage Model Type 45S	
Deadman Seat Brake	
Fully Oil Charged Lift Cylinder	

**TOYOTA MOTOR CORPORATION**  
**TOYODA AUTOMATIC LOOM WORKS, LTD.**

QUICK REFERENCE INDEX	
INTRODUCTION	█
ELECTRICAL SYSTEM	█
CHASSIS	█
BODY	█
ELECTRICAL SYSTEM	█
MAST	█
HYDRAULIC SYSTEM	█
	█
	█
	█

## GENERAL INFORMATION

This parts catalog has been prepared for the customers of Toyota Industrial Vehicles and this shows only the part name codes instead of parts numbers.

When ordering parts from your local Toyota dealer, please specify the complete model number of the truck, the engine number or frame number. Also it is essential that you specify the part name codes described in the pages of illustrations and text.

The complete model number and frame number are shown in the front page of this catalog. All the columns in this quick reference index are supposed to be filled out by both the factory and your local dealer.

For the industrial vehicle with optional equipment, which is described in the lower part of the DESCRIPTION, it is imperative for you to specify optional equipment when ordering parts.

Your Toyota dealer has always been furnished with enough information to decode the correct part numbers based on your information of model number, engine number or frame number as well as part name code.

## INFORMATIONS D'ORDRE GENERAL

Ce catalogue de pièces a été préparé pour les propriétaires de Véhicules Industriels Toyota. On n'y trouvera que les codes de désignation de pièces au lieu des numéros de pièces.

Pour la commande de pièces auprès de votre concessionnaire Toyota, prière de spécifier le numéro de modèle complet de l'engin, le numéro du moteur ou le numéro du châssis. Il est aussi nécessaire de spécifier les codes de désignation de pièces comme ils sont décrits dans les pages d'illustrations et dans le texte.

Le numéro de modèle complet et le numéro de châssis sont indiqués en première page de ce catalogue. Toutes les colonnes de l'index de référence rapide devraient être remplies par l'usine et par votre concessionnaire.

Pour le véhicule industriel avec équipement optionnel, décrit en bas de page sous la rubrique "DESCRIPTION", il convient de bien spécifier qu'il s'agit de cet équipement lors de commande de pièces.

Votre concessionnaire Toyota est toujours suffisamment informé pour décoder les numéros de pièces sur la base de votre information du numéro de modèle, du numéro de moteur ou de châssis, et des codes de désignation de pièces.

## INFORMACION GENERAL

Este catálogo de piezas ha sido preparado para los clientes de vehículos industriales de TOYOTA, e incluye tan sólo los códigos de nombre de pieza en lugar de los números de pieza.

Cuando solicite piezas a su distribuidor local de TOYOTA especifique por favor el número de modelo completo del vehículo, el número de motor o el número de bastidor. Asimismo, es esencial que Vd. especifique los códigos de nombre de pieza descritos en las páginas de ilustraciones y de texto.

El número completo de modelo y el número de bastidor se indican en la portada de este catálogo. Se supone que todas las columnas de este índice de referencia se han rellenado, tanto por parte de la fábrica como por parte de su distribuidor local.

En lo que concierne a los vehículos industriales con equipos opcionales, que se describen en la parte baja de la DESCRIPCION, es absolutamente necesario que especifique equipos opcionales cuando solicite piezas de repuesto.

Su distribuidor local de TOYOTA posee la información necesaria para descifrar los números correctos de cada pieza a base de su información de número de modelo, número de motor o número de bastidor, así como el código de nombre de la pieza.

## ALLGEMEINE INFORMATION

Dieser Teilekatalog wurde für die Benutzer von Toyota Industriefahrzeugen zusammengestellt und zeigt anstelle von Teilenummern nur die Teilennamen-Kodes.

Geben Sie bei Teilebestellungen von Ihrem Toyota-Händler am Platz bitte die vollständige Modellnummer des Fahrzeugs, die Motornummer oder Fahrgestellnummer an. Es ist auch erforderlich, daß Sie die in den Illustrationen und im Text beschriebenen Teilennamen-Kodes angeben.

Die vollständige Modellnummer und Fahrgestellnummer finden Sie auf der Vorderseite dieses Katalogs. Alle Spalten in dieser Bezugstabelle sollen sowohl vom Werk als von Ihrem Händler am Platz ausgefüllt werden.

Für Industriefahrzeuge mit Sonderausrüstung, welche im unteren Teil der BESCHREIBUNG erläutert ist, müssen Sie bei der Bestellung von Teilen unbedingt diesbezügliche Angaben machen.

Ihr Toyota-Händler verfügt stets über genügend Information, um die richtigen Teilenummern zu entschlüsseln, basiert auf Ihren Angaben zu Modellnummer, Motornummer oder Fahrgestellnummer und den Teilennamen-Kodes.

## ILLUSTRATION AND PART NAME CODE TEXT PAGE COMPOSITION

Essentially, one (1) page will present both the illustration and part name code. However, when the space for text page is not enough the next page will be used in succession.

## COMPOSICION DE LAS PAGINAS DE ILUSTRACIONES Y DE TEXTO DE CODIGOS DE NOMBRE DE PIEZAS

Básicamente, una (1) página incluirá tanto la ilustración como el código de nombre de la pieza.

No obstante, si el espacio no fuese suficiente, se utilizará la página siguiente.

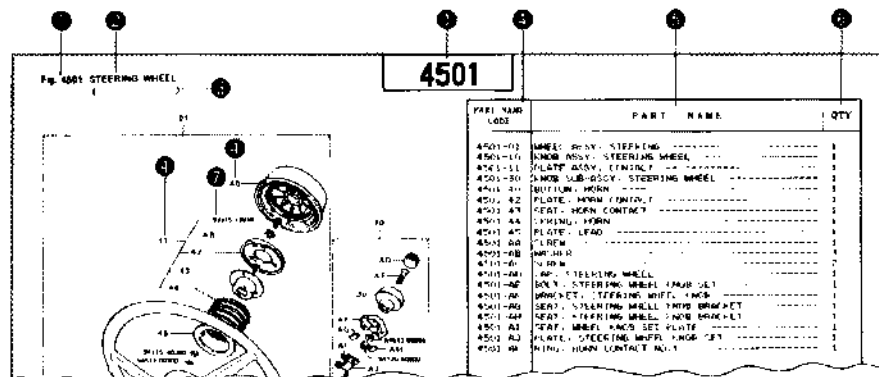

- Figure number**  
This parts catalog has been prepared according to the figure numbers.
- Figure title**  
A representative part name which is the major assembly part name is shown as the figure title of the illustration.
- Sub title**  
The optional name or special specification of each illustration are indicated.
- Part name code**  
This is a combination of figure number and codes of illustrations pertaining to each part. This is a key for your Toyota dealer to find the correct part numbers.
- Part name**  
As a rule, the part name is indicated for each of the part name codes.
- QTY (Quantity)**  
The quantity column indicates the utilized pieces of part name code unit. When the utilized quantity changes according to each of the vehicles, maximum is indicated. When the utilized quantity of the parts differs or is more than 100 pieces, quantity 99 is indicated.
- Standard parts numbers**  
The standard parts such as the bolts, nuts, washer, etc. are described with parts numbers. When ordering these parts, specify parts numbers.

- Número de figura**  
Este catálogo de piezas se ha preparado de acuerdo con los números de las figuras.
- Título de las figuras**  
Como título de las figuras de la página de ilustraciones, se incluye un nombre que sea representativo del nombre del mayor conjunto.
- Subtítulo**  
Se indican el nombre opcional o las especificaciones especiales de cada ilustración.
- Código de nombre de pieza**  
Se trata de una combinación de número de figura y de código de las ilustraciones correspondientes a cada pieza. Esta es la clave para que su distribuidor local de TOYOTA pueda encontrar el número de pieza correcta.
- Nombre de la pieza**  
Como norma, se indica el nombre de cada uno de los códigos de nombre de pieza.
- QTY (Cantidad)**  
La columna de cantidad indica el número de piezas utilizadas de cada unidad de código de nombre de pieza. Cuando la cantidad utilizada es intercambiable entre cada uno de los vehículos, se indica el máximo. Cuando la cantidad de piezas utilizadas pueda diferir o ser superior a 100, se indica como cantidad 99.
- Números de piezas normalizadas**  
Las piezas corrientes, tales como pernos, tuercas, arandelas etc., se describen con número de pieza. Cuando solicite tales piezas, indique su número de pieza.

## ILLUSTRATION ET COMPOSITION DU DE TEXTE DE CODE DE DESIGNATION DE PIECE

Une (1) page contiendra essentiellement une illustration et ses codes de désignation de pièce. Toutefois, lorsque l'espace réservé au texte est insuffisant, la continuation se trouvera sur la page suivante.

## ABBILDUNG UND TEXTSEITENAUFBAU FÜR TEILENAMEN-KODE

Grundsätzlich finden Sie auf einer (1) Seite sowohl die Abbildung als auch den Teilnamen-Kode.

Wenn für den Text jedoch nicht genügend Platz vorhanden ist, wird er auf der nächsten Seite fortgesetzt.

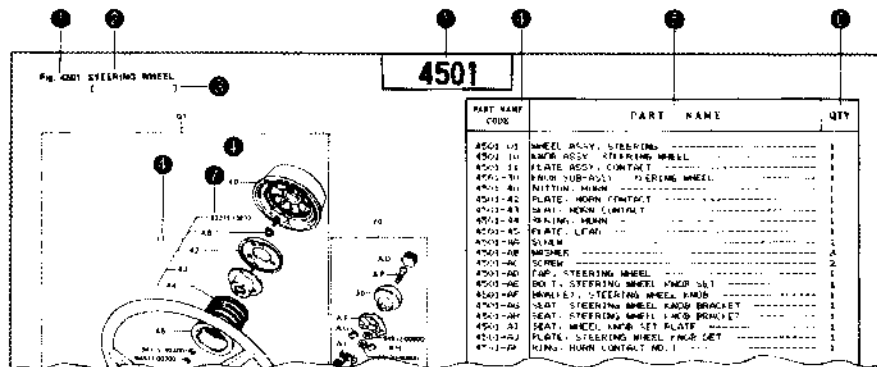

- Numéro de figure**  
Ce catalogue de pièces a été préparé en fonction des numéros de figures.
- Titre de figure**  
Une désignation de pièce représentative, celle d'une pièce d'un ensemble important, est indiquée comme titre de figure de l'illustration.
- Sous-titre**  
La désignation optionnelle ou les spécifications spéciales de chaque illustration sont indiquées.
- Code de désignation de pièce**  
Obtenu en combinant le numéro de figure et les codes des illustrations inhérents à chaque pièce. Ce code permettra à votre concessionnaire Toyota de trouver les numéros de pièces corrects.
- Désignation de pièce**  
La désignation de la pièce est indiquée pour chacun des codes de désignation de pièce.
- Qty (quantité)**  
La colonne quantité indique les pièces utilisées de l'unité de code de désignation de pièce. La quantité maximum est indiquée quand la quantité utilisée diffère pour chacun des véhicules. Quand la quantité de pièces utilisées diffère ou lorsqu'elle dépasse 100 pièces, la quantité 99 est indiquée.
- Numéros de pièces standard**  
Les pièces standard comme les boulons, les écrous, les rondelles, etc. sont décrits dans les numéros de pièces. Pour commander ces pièces, prière de spécifier les numéros de pièces.

- Abbildungsnummer**  
Dieser Teilekatalog wurde nach Abbildungsnummern zusammengestellt.
- Abbildungstitel**  
Ein stellvertretender Teilname, welcher zugleich die Bezeichnung für die Hauptbaugruppe ist, wird als Abbildungstitel der Illustration angegeben.
- Untertitel**  
Ein zusätzlicher Name oder eine besondere Kennzeichnung werden für jede Illustration angegeben.
- Teilnamen Kode**  
Dies ist eine Kombination von ziffern und Abbildungskodes, die jedes Teil betreffen. Es ist ein Schlüssel für Ihren Toyota-Händler, um die richtigen Teilnummern zu finden.
- Teilname**  
Grundsätzlich wird der Teilname für alle Teilnamen-Kodes angegeben.
- QTY (Menge)**  
Die Mengenspalte gibt die benutzte Stückzahl von Teilnamen Kode-Einheiten an. Wenn die benutzte Stückzahl je nach Fahrzeug Verschieden ist, wird die Höchstmenge angegeben. Wenn die benutzte Menge 100 Stück überschreiten kann, wird als Menge 99 angegeben.
- Standardteile-Nummern**  
Die Standardteile, wie Schrauben, Muttern, Unterlegscheiben usw., sind in den Teilnummern beschrieben. Geben Sie bei Bestellung dieser Teile die Teilnummern an.

## DATA PLATE & SERIAL NUMBERS

For retrieving correct part numbers, it's indispensable to know the truck model, as well as frame number ( or engine number).  
Customers can obtain said information in the data plate on the truck or in this user parts catalog.

## PLAQUE DE DONNEES TECHNIQUES & NUMEROS DE SERIE

Pour relever correctement le numéro des pièces, il est indispensable de connaître le modèle de l'engin, ainsi que le numéro du châssis (ou du moteur).  
Les propriétaires peuvent trouver ladite information sur la plaque de données techniques de l'engin ou dans le présent ouvrage.

## PLACA DE DATOS Y NUMEROS DE SERIE

Para obtener los números de pieza correctos, es indispensable conocer el modelo del vehículo, así como el número del bastidor (o del motor).  
Los clientes pueden obtener dicha información por la placa de datos del vehículo o este catálogo de piezas para el usuario.

## DATENPLATTE & SERIENNUMMERN

Um die richtige Teilenummer zu ermitteln, müssen unbedingt das Fahrzeugmodell sowie die Fahrgestellnummer (oder die Motornummer) bekannt sein.  
Kunden können diese Angaben von der Datenplatte am Fahrzeug oder in diesem Teilekatalog für Benutzer entnehmen.

Data plate  
Placa de datos  
Plaque de données techniques  
Datenplatte

 <b>TOYOTA LIFT TRUCK</b>	
MODEL	<input type="text"/>
CODE NO. OF SPECIAL MODEL, MODEL OF ATTACHMENT	
<input type="text"/>	
VOLTAGE	<input type="text"/>
FRAME NO.	<input type="text"/>
LIFTING HEIGHT	<input type="text"/>
CAPACITY	<input type="text"/>
WEIGHT	<input type="text"/>
PROD. YEAR	<input type="text"/>
<b>TOYODA AUTOMATIC LOOM WORKS. LTD. KARIYA JAPAN</b>	

Data plate  
Placa de datos  
Plaque de données techniques  
Datenplatte

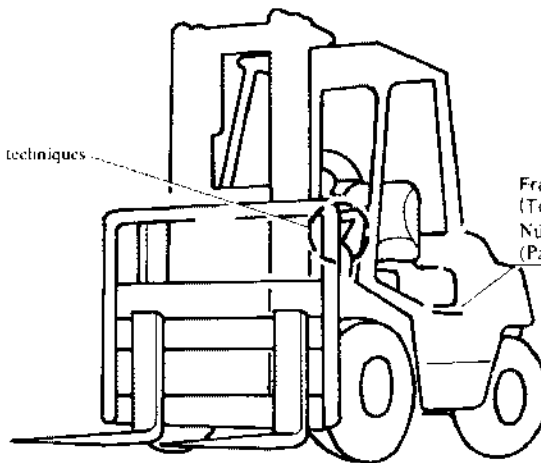

Frame Number  
(Top of the frame)  
Número de bastidor  
(Parte superior del bastidor)

Numéro de châssis  
(haut du châssis)  
Fahrgestellnummer  
(Oben am Fahrgestell)

# FIG. INDEX

FIG. 1401

1

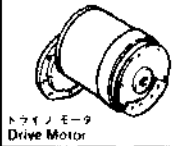

FIG. 1402

2

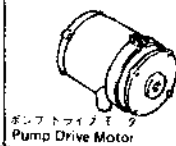

FIG. 1403

3

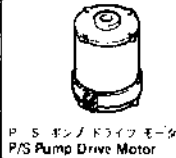

FIG. 2401

4

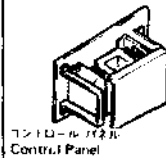

FIG. 2402

5

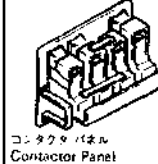

FIG. 2403

6

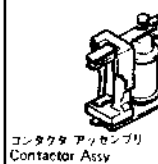
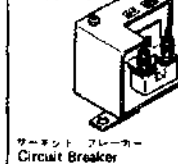

FIG. 2413

7



電気的グループ  
ELECTRICAL GROUP

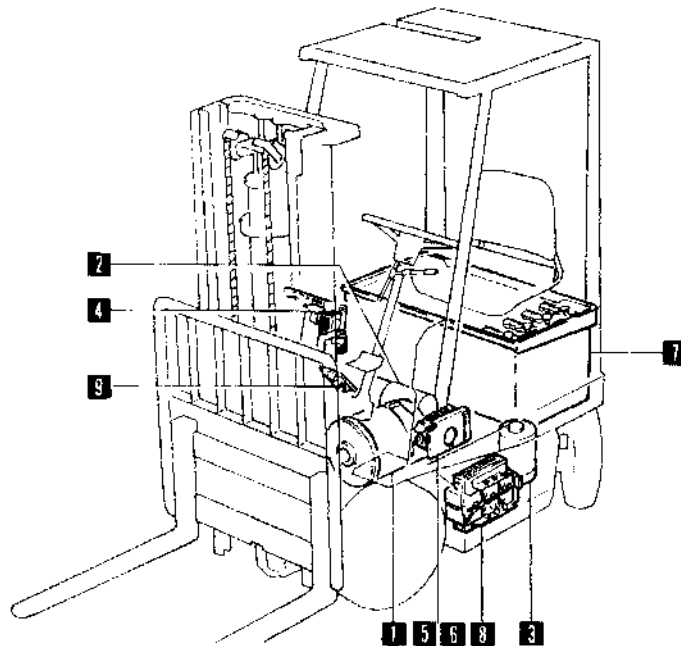

FIG. 2501

7

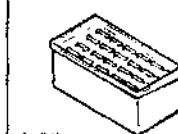

FIG. 2512

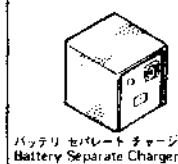
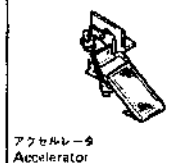

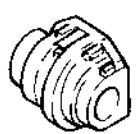
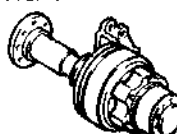
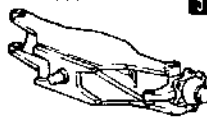

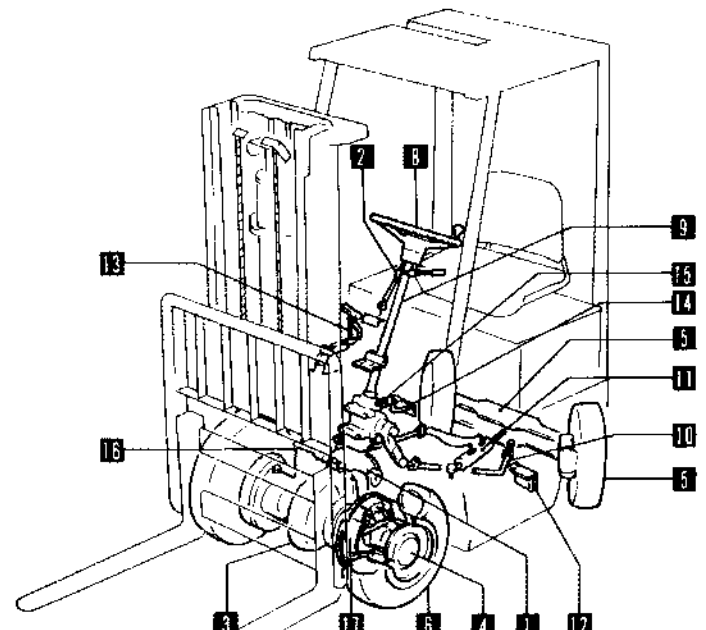



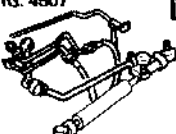

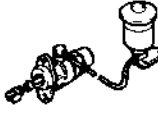
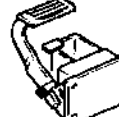

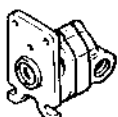
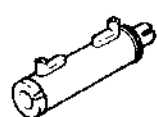

FIG. 2611

9







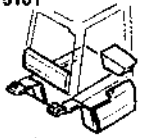
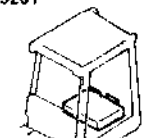

# FIG. INDEX

<p>FIG. 3305 <b>1</b></p>  <p>ギヤケースとギヤ Gear Case &amp; Gear</p>	<p>FIG. 3310 <b>2</b></p>  <p>チェンジレバー Change Lever</p>	<p>FIG. 4101 <b>3</b></p>  <p>ディファレンシャル Differential</p>	<p>FIG. 4201 <b>4</b></p>  <p>フロントアクスルシャフト Front Axle Shaft</p>	<p>FIG. 4301 <b>5</b></p>  <p>リヤアクスルトイロッド Rear Axle &amp; Tie-Rod</p>	<p>FIG. 4401 <b>6</b></p>  <p>フロントホイールとタイヤ Front Wheel &amp; Tire</p>	<p>FIG. 4402</p>  <p>フロントホイールとタイヤ(ダブル) Front Wheel &amp; Tire (Double)</p>	
<p>シャシ グループ CHASSIS GROUP</p> 							<p>FIG. 4403 <b>7</b></p>  <p>リヤホイールとタイヤ Rear Wheel &amp; Tire</p>
							<p>FIG. 4501 <b>8</b></p>  <p>ステアリングホイール Steering Wheel</p>
							<p>FIG. 4502 <b>9</b></p>  <p>ステアリングポスト Steering Post</p>
							<p>FIG. 4507 <b>10</b></p>  <p>ドラッグリンクとパイピング Draglink &amp; Steering Piping</p>
<p>FIG. 4715 <b>11</b></p>  <p>ドラムブレーキ Drum Brake</p>	<p>FIG. 4714 <b>13</b></p>  <p>ブレーキパイプ Brake Pipe</p>	<p>FIG. 4702 <b>15</b></p>  <p>ブレーキマスターシリンダ Brake Master Cylinder</p>	<p>FIG. 4701 <b>14</b></p>  <p>ブレーキペダル Brake Pedal</p>	<p>FIG. 4601 <b>16</b></p>  <p>パーキングブレーキ Parking Brake</p>	<p>FIG. 4510 <b>12</b></p>  <p>ステアリングオイルポンプ Steering Oil Pump</p>	<p>FIG. 4508 <b>17</b></p>  <p>ステアリングパワーシリンダ Steering Power Cylinder</p>	

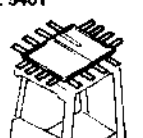

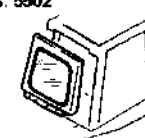
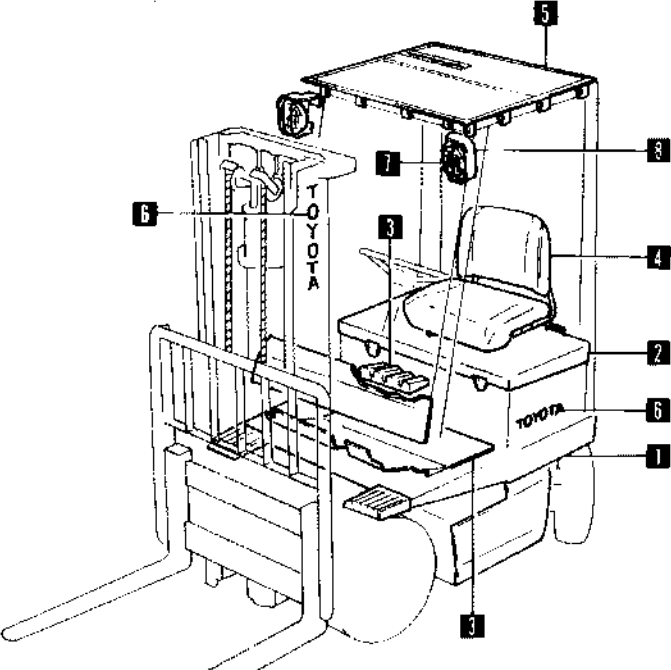
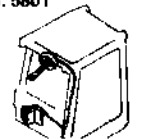
# FIG. INDEX

<p>FIG. 5101</p>  <p>フレームトウエイト Frame &amp; Weight</p>	<p>FIG. 5201</p>  <p>フードとヒンジ Hood &amp; Hinge</p>	<p>FIG. 5301</p>  <p>インストルメントパネルとフロア Instrument Panel &amp; Floor</p>	<p>FIG. 5308</p>  <p>ドライバシート Driver Seat</p>	<p>FIG. 5401</p>  <p>ヘッドガードアクセサリー Head Guard &amp; Accessory</p>	<p>FIG. 5406</p>  <p>インジケータプレート Indicator Plate</p>	<p>FIG. 5502</p>  <p>キャンバスキャビンとフロントガラス Canvas Cabin &amp; Front Glass</p>	
<p>ボデー、電気リカルグループ BODY, ELECTRICAL GROUP</p>							
							
						<p>FIG. 5801</p>  <p>ワイパーモーターブレード Wiper Motor &amp; Blade</p>	<p>FIG. 5706</p>  <p>スピードメータスピードアラーム Speedo Meter &amp; Speed Alarm</p>

# FIG. INDEX











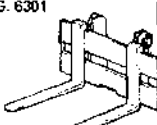

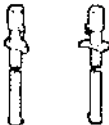
<p>FIG. 6101 <b>1</b></p>  <p>マスト Mast</p>	<p>FIG. 6301 <b>2</b></p>  <p>リフトブラケットフォーク Lift Bracket &amp; Fork</p>	<p>FIG. 6302 <b>3</b></p>  <p>チェーンとチェーンホイール Chain &amp; Chain Wheel</p>	<p>FIG. 6501 (SV, V) <b>4</b></p>  <p>リフトシリンダ Lift Cylinder</p>	<p>FIG. 6502 (FV, FSV) <b>5</b></p>  <p>フロントリフトシリンダ Front Lift Cylinder</p>	<p>FIG. 6503 (FV, FSV) <b>6</b></p>  <p>リアリフトシリンダ Rear Lift Cylinder</p>	<p>FIG. 6504 (M) <b>8</b></p>  <p>リフトシリンダ Lift Cylinder</p>	
<p>マスト ハイドロリック コンポーネント グループ MAST, HYDRAULIC COMPONENT GROUP</p> 							<p>FIG. 6505 (F, FS) <b>5</b></p>  <p>フロントリフトシリンダ Front Lift Cylinder</p>
							<p>FIG. 6506 (F, FS) <b>6</b></p>  <p>リアリフトシリンダ Rear Lift Cylinder</p>
							<p>FIG. 6511 <b>6</b></p>  <p>チルトシリンダ Tilt Cylinder</p>
							<p>FIG. 6701 <b>7</b></p>  <p>オイルポンプ Oil Pump</p>
							<p>FIG. 6705 <b>8</b></p>  <p>オイルコントロールバルブ Oil Control Valve</p>
			<p>FIG. 6802 <b>4</b></p>  <p>マストパイピング Mast Piping</p>	<p>FIG. 6801 <b>4</b></p>  <p>本体パイピング Body Piping</p>	<p>FIG. 6709 <b>9</b></p>  <p>オイルコントロールバルブリンク Oil Control Valve Link</p>		

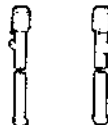
FIG. 0901 STANDARD TOOL

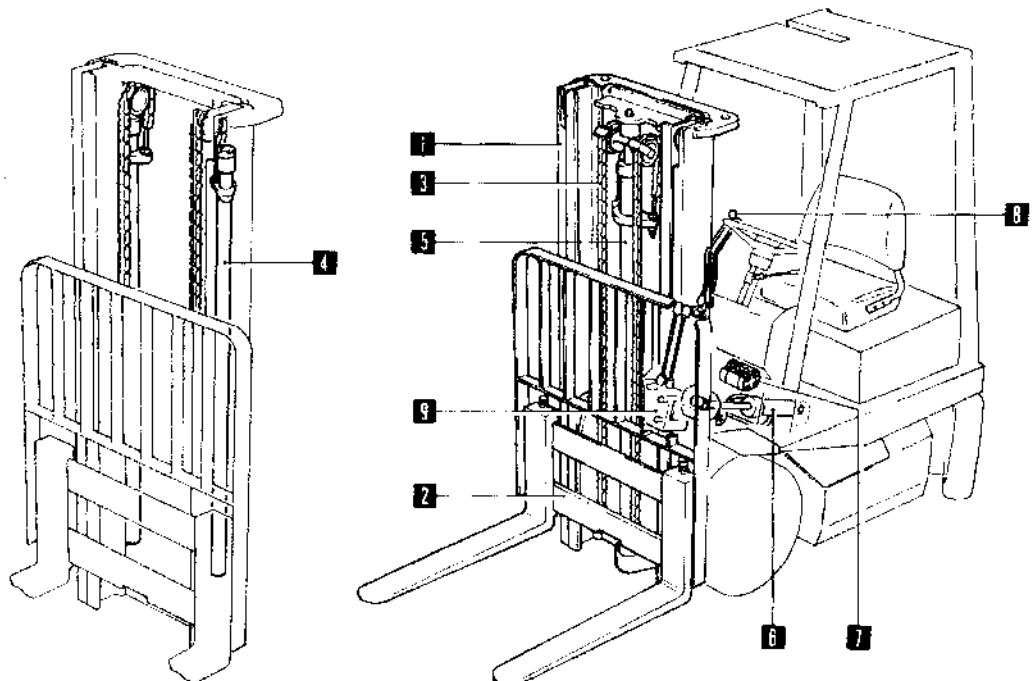
0901

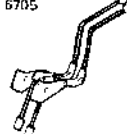

PART NAME CODE	PART NAME	QTY
0901-01	TOOL SET, STANDARD -----	1
0901-10	SPANNER SET -----	1
0901-11	PUMP ASSY, GREASE -----	1
0901-12	METER ASSY, HYDRAULIC SAILING -----	1
0901-40	BAG, TOOL -----	1
0901-41	PRIERS -----	1
0901-42	DRIVER, SCREW -----	1
0901-43	WRENCH, MONKEY -----	1
0901-45	ROD, THERMOMETER -----	1
0901-46	FUSE -----	1
0901-47	WRENCH, HUB NUT BOX -----	1

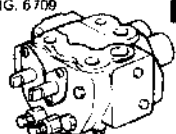
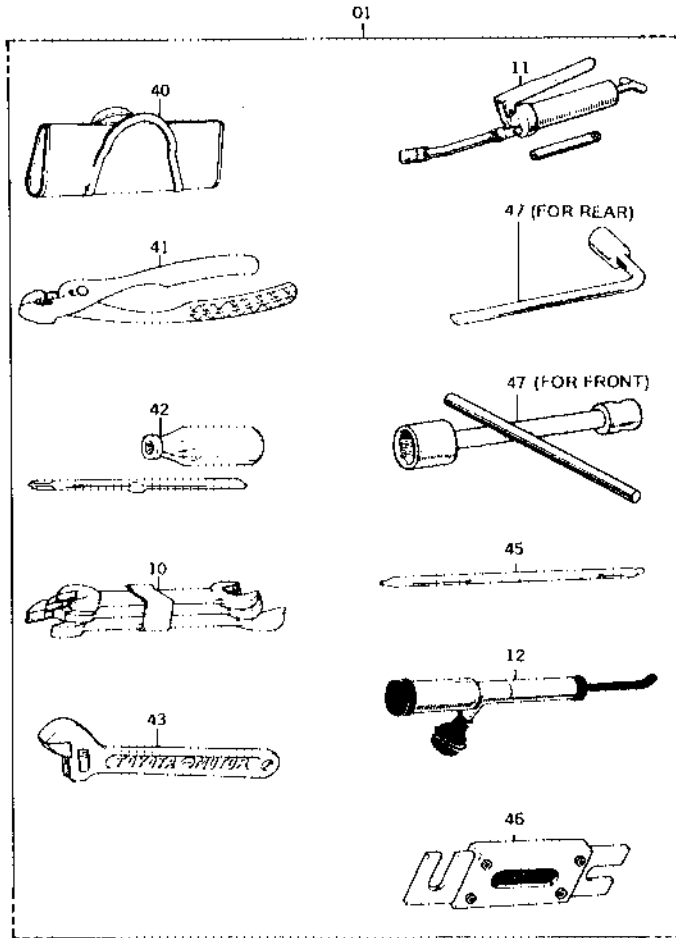
(MAIN ) ( 1)

G208

FIG. 1401 DRIVE MOTOR

1401

DPR

HSP

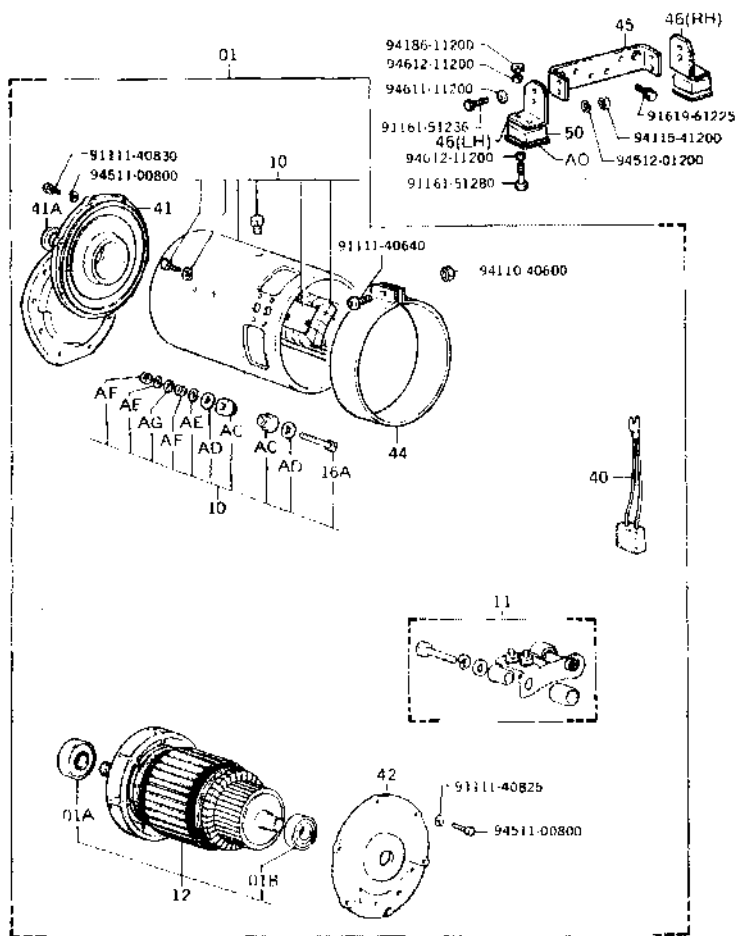

1401-023

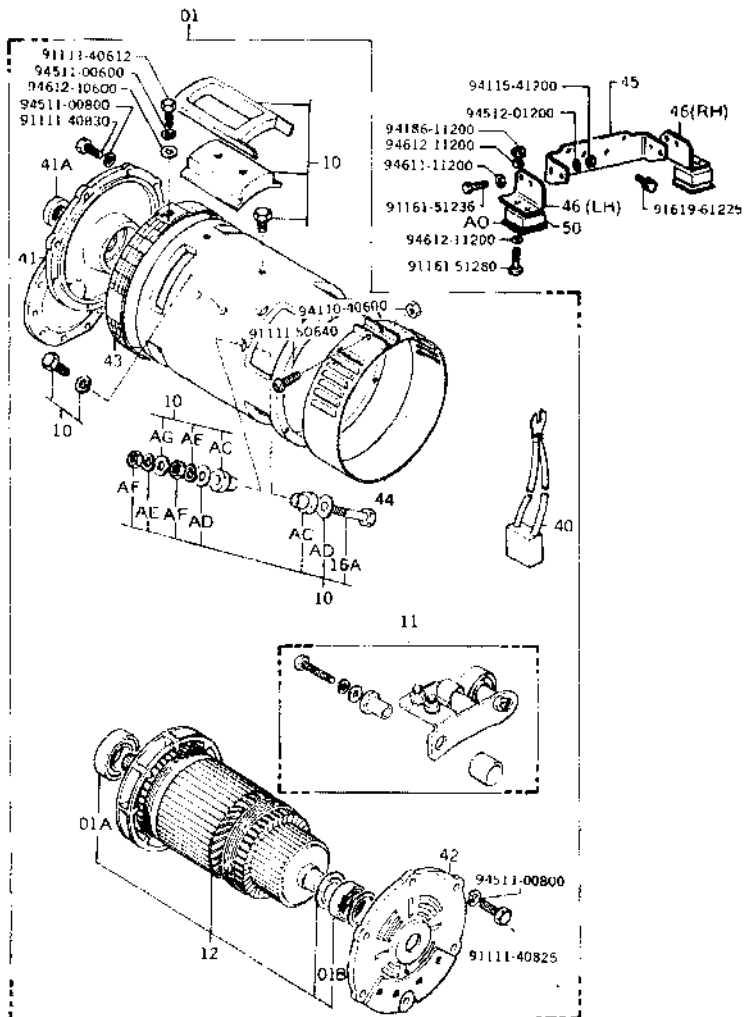

1401-017

FIG. 1401 DRIVE MOTOR

1401

HSP (UL-E)

STM

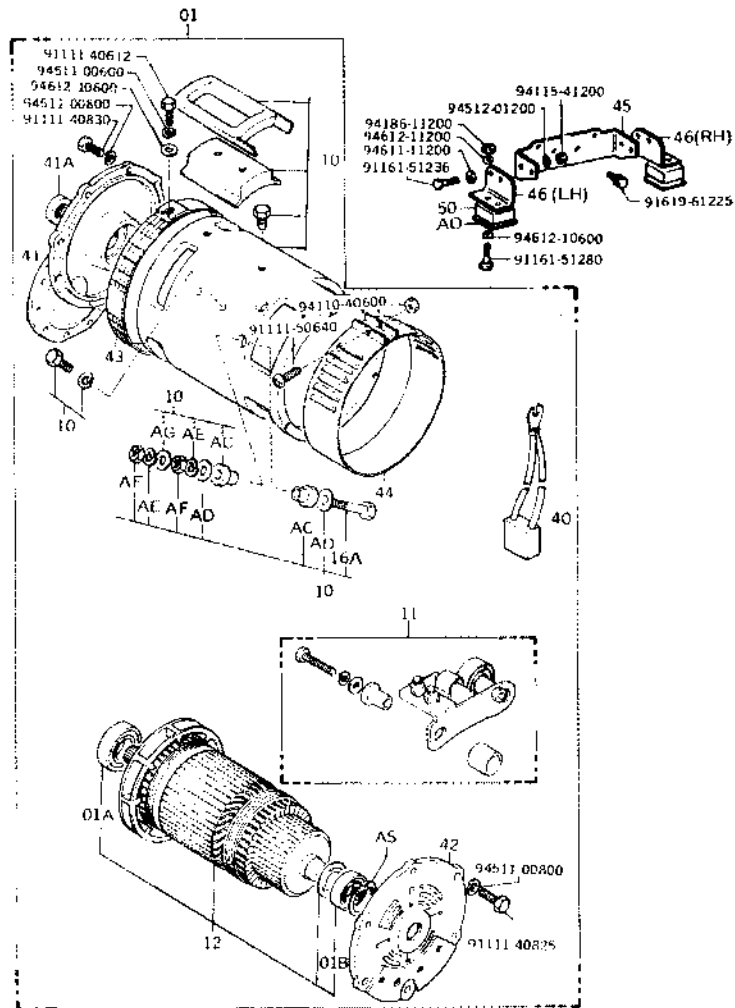

1401-019

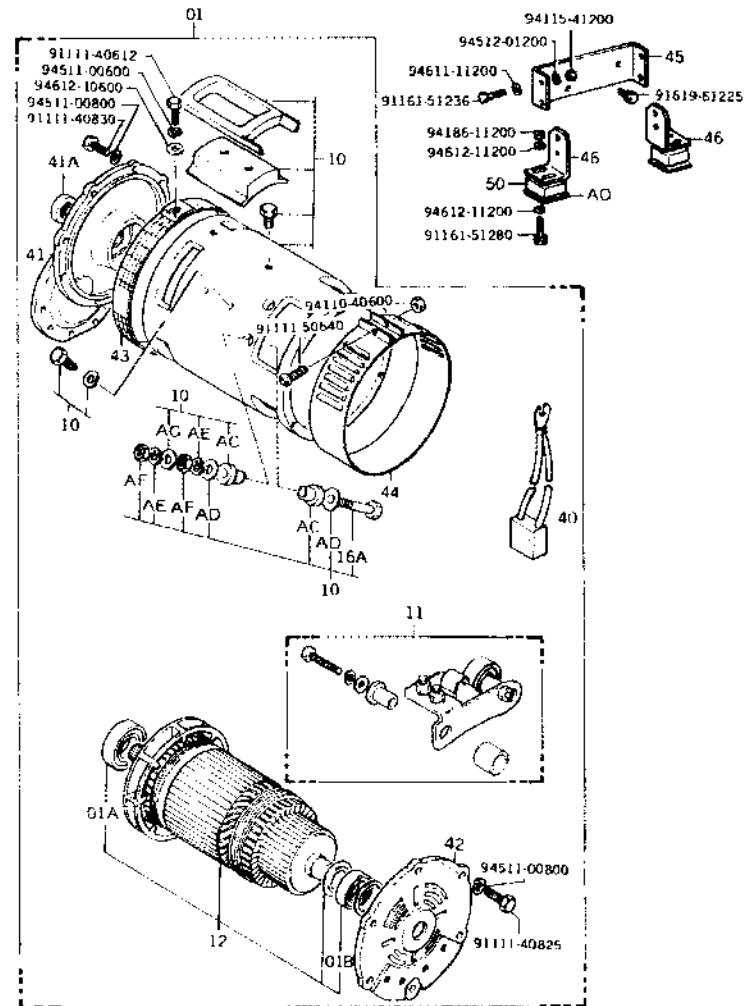

1401-016

FIG. 1401 DRIVE MOTOR

1401

STM (UL-E)

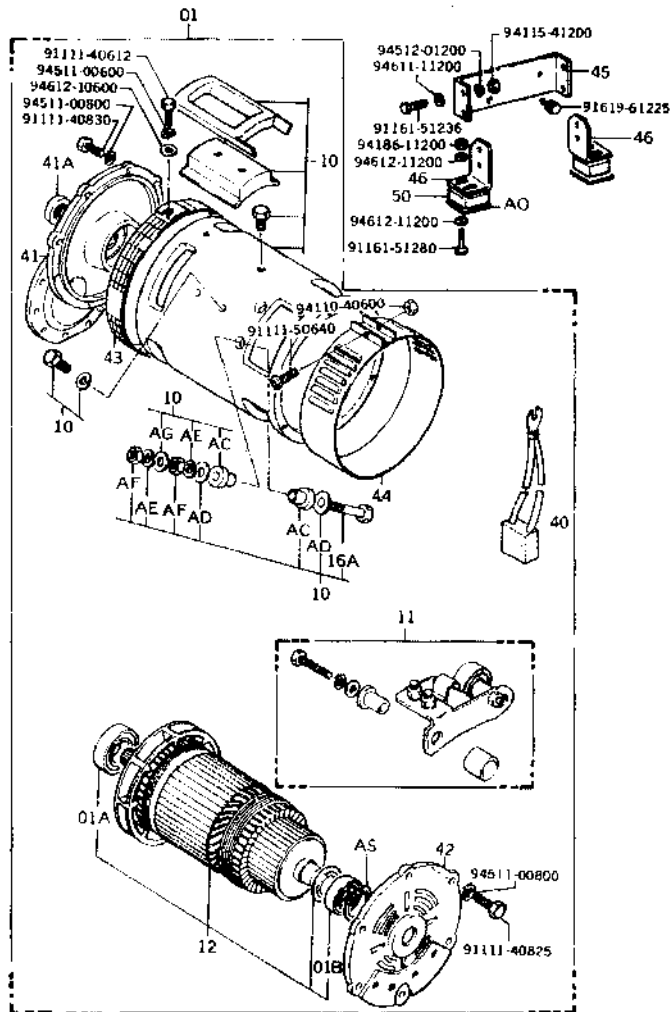

1401-01B

PART NAME CODE	PART NAME	QTY
1401-01	MOTOR ASSY, DRIVE -----	1
1401-01A	BEARING, DRIVE MOTOR, NO.1 -----	1
1401-01B	BEARING, DRIVE MOTOR, NO.2 -----	1
1401-10	YKE ASSY -----	1
1401-11	HOLDER ASSY, BRUSH -----	1- 4
1401-12	ARMATURE ASSY, DRIVE -----	1
1401-16A	BOLT, STUD (TERMINAL) -----	1- 4
1401-40	BRUSH, DRIVE MOTOR -----	4
1401-41	BRACKET, NO.1 -----	1
1401-41A	SEAL, OIL (FOR BRACKET) -----	1
1401-42	BRACKET, NO.2 -----	1
1401-43	COVER, MOTOR -----	1
1401-44	COVER, BRUSH -----	1
1401-45	BRACKET, DRIVE MOTOR MOUNTING, NO.1 -----	1
1401-46	BRACKET, DRIVE MOTOR MOUNTING, NO.2 -----	1- 2
1401-50	RUBBER, CUSHION (FOR MOTOR MOUNTING) -----	4
1401-AC	INSULATOR -----	8
1401-A0	WASHER, PLATE -----	8
1401-AE	WASHER, SPRING -----	8
1401-AF	NUT -----	8
1401-AG	WASHER, PLATE -----	4- 8
1401-A0	PLATE, CUSHION RUBBER -----	2
1401-AS	WASHER, WAVE -----	1

FIG. 1402 PUMP DRIVE MOTOR

1402

HSP, STM, HSP, STM (UL-E)

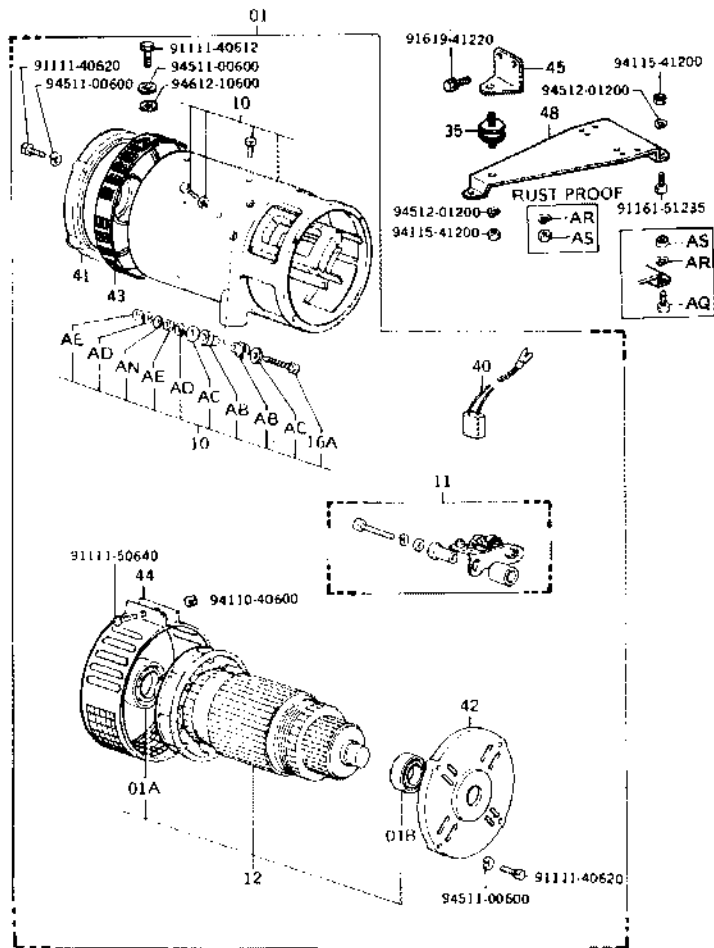

1402-019

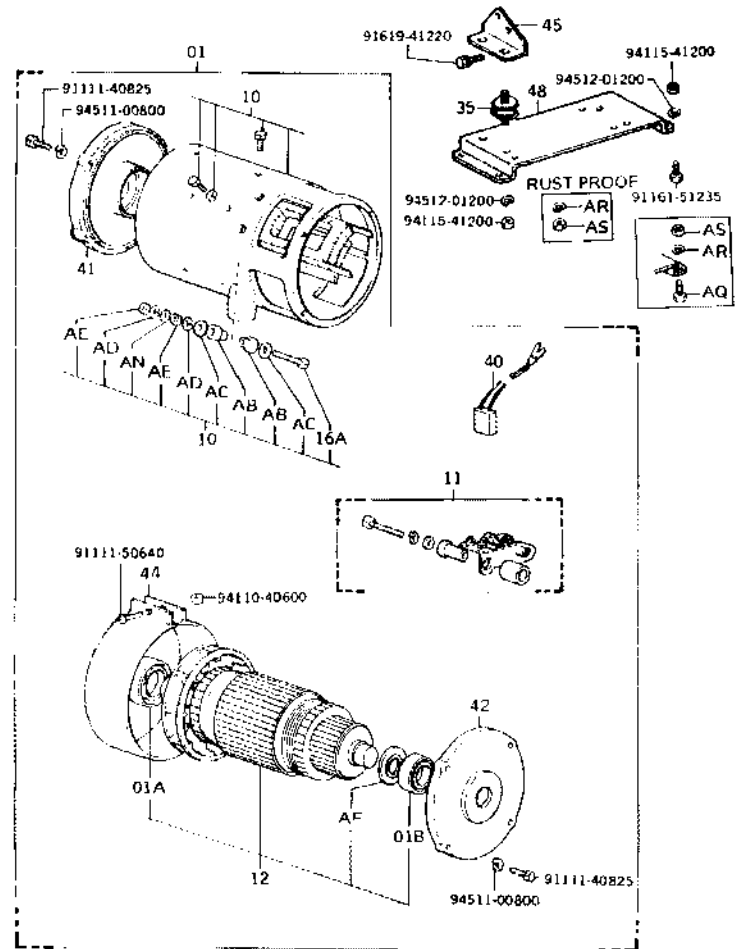

1402-021

# 1402

PART NAME CODE	PART NAME	QTY
1402-01	MOTOR ASSY, PUMP -----	1
1402-01A	BEARING, PUMP MOTOR, NO.1 -----	1
1402-01B	BEARING, PUMP MOTOR, NO.2 -----	1
1402-10	YOKE ASSY, PUMP MOTOR -----	1
1402-11	HOLDER ASSY, PUMP MOTOR -----	4
1402-12	ARMATURE ASSY, PUMP MOTOR -----	1
1402-16A	BOLT, STUD (TERMINAL) -----	1- 2
1402-35	INSULATOR SUB-ASSY, MOTOR MOUNTING -----	3
1402-40	BRUSH, PUMP MOTOR -----	4
1402-41	BRACKET, NO.1 -----	1
1402-42	BRACKET, NO.2 -----	1
1402-43	COVER, MOTOR -----	1
1402-44	COVER, BRUSH -----	1
1402-45	BRACKET, PUMP MOTOR MOUNTING -----	1
1402-48	PLATE, PUMP MOTOR SET -----	1
1402-AB	INSULATOR -----	4- 6
1402-AC	WASHER, PLATE -----	4- 6
1402-AD	WASHER, SPRING -----	4- 6
1402-AE	NUT -----	4- 6
1402-AN	WASHER, PLATE -----	4- 6
1402-AQ	BOLT -----	3
1402-AR	WASHER, SPRING -----	7
1402-AS	NUT -----	7

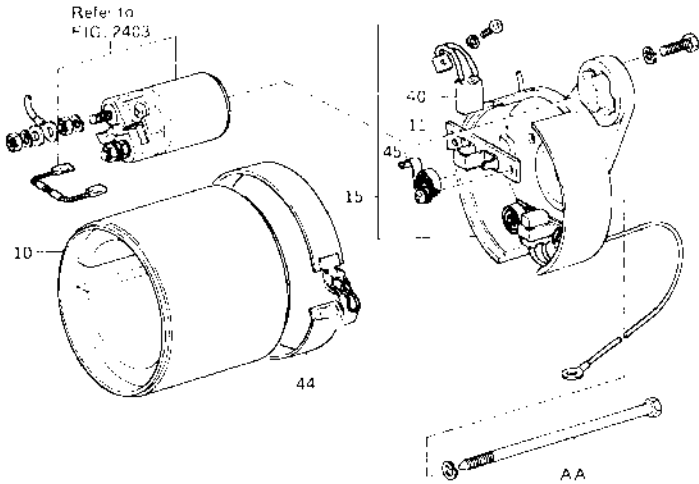
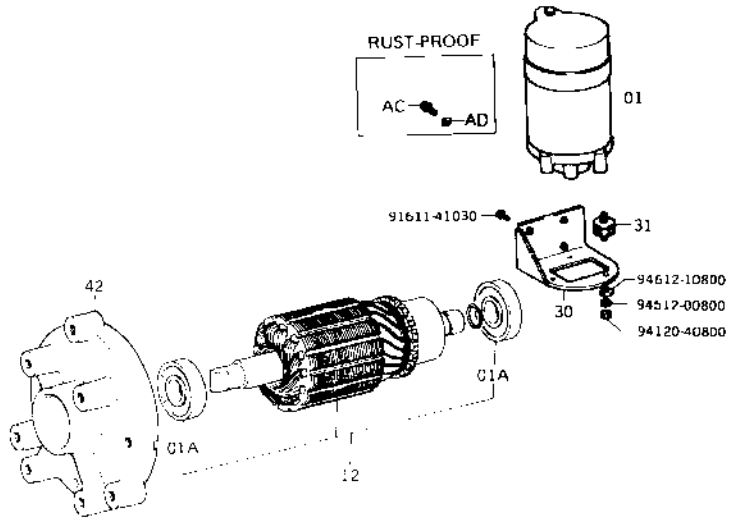

FIG. 1403 POWER STEERING PUMP DRIVE MOTOR

1403

(P/S..ND)

(P/S..MEIDEN, UL-E)



Refer to FIG. 2403

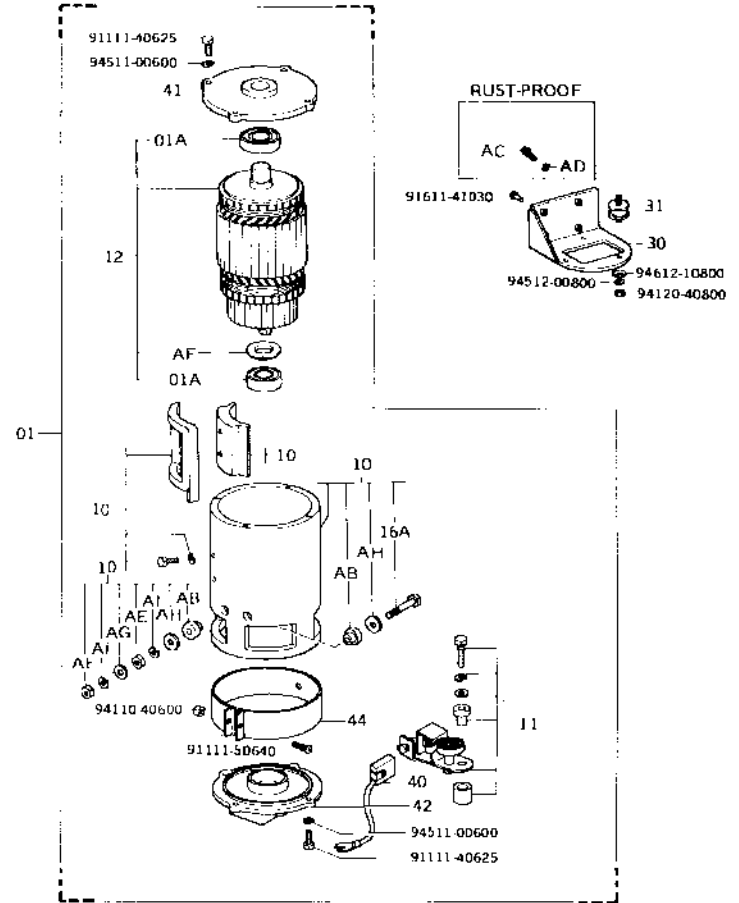

1403 002

1403 003

**1403**

PART NAME CODE	PART NAME	QTY
1403-01	MOTOR ASSY, POWER STEERING -----	1
1403-01A	BEARING, POWER STEERING MOTOR -----	2
1403-10	YOKE ASSY, POWER STEERING MOTOR -----	1
1403-11	HOLDER ASSY, BRUSH -----	2
1403-12	ARMATURE ASSY, POWER STEERING -----	1
1403-15	FRAME ASSY, COMMUTATOR -----	1
1403-16A	BOLT, STUD (TERMINAL) -----	1
1403-30	BRACKET SUB-ASSY, MOTOR MOUNTING -----	1
1403-31	INSULATOR SUB-ASSY, BODY MOUNTING -----	3
1403-40	BRUSH, POWER STEERING MOTOR -----	2
1403-41	BRACKET, NO.1 -----	1
1403-42	BRACKET, NO.2 -----	1
1403-44	COVER, BRUSH -----	1
1403-45	SPRING, POWER STEERING MOTOR BRUSH -----	2
1403-AA	BOLT -----	2
1403-AB	INSULATOR -----	4
1403-AC	BOLT -----	4
1403-AD	WASHER, SPRING -----	4
1403-AE	NUT -----	4
1403-AF	FRINGER -----	1
1403-AG	WASHER, PLATE -----	4
1403-AH	WASHER, PLATE -----	4
1403-AI	WASHER, SPRING -----	4



FIG. 2401 CONTROL PANEL

2401

HSP

01

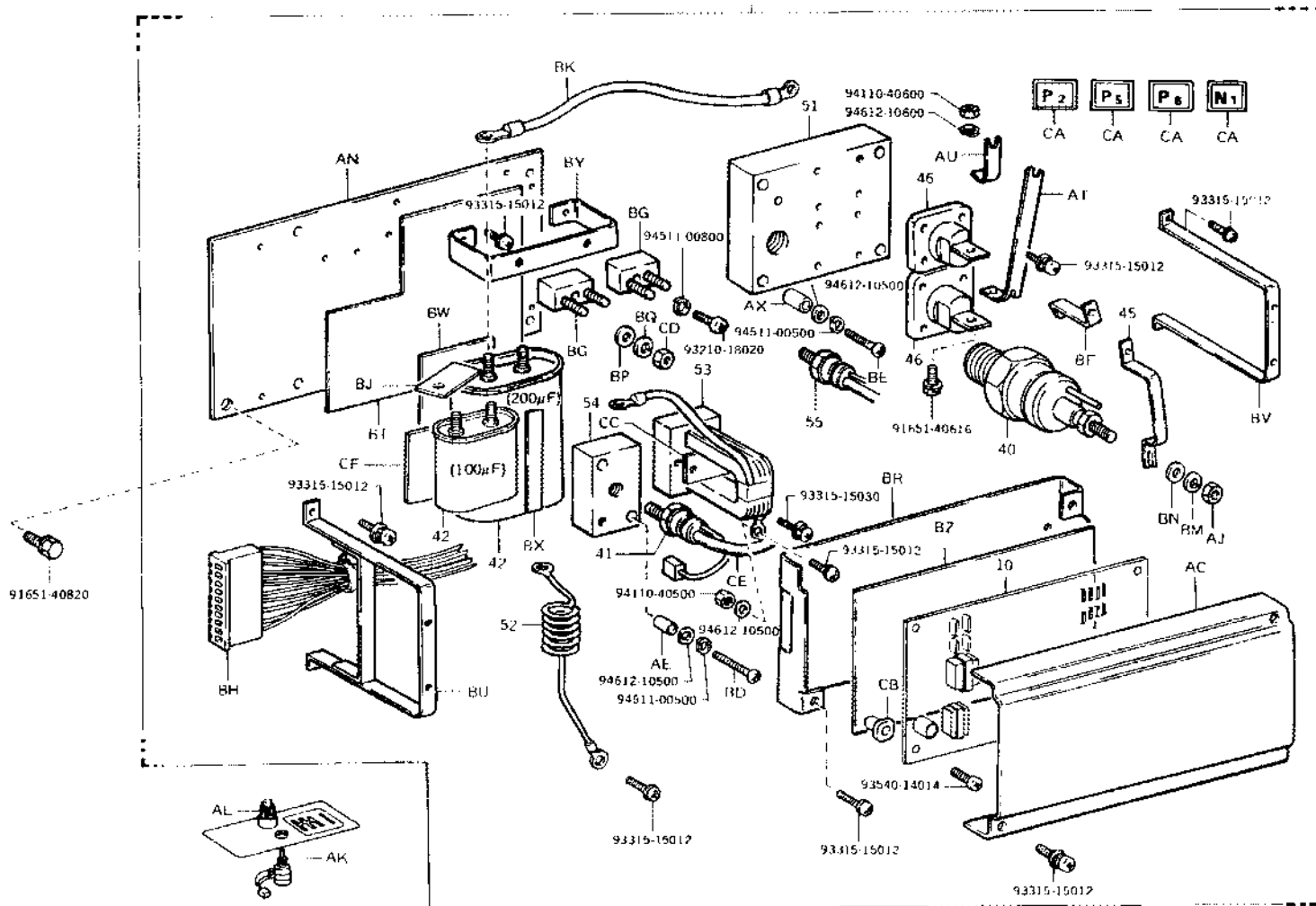
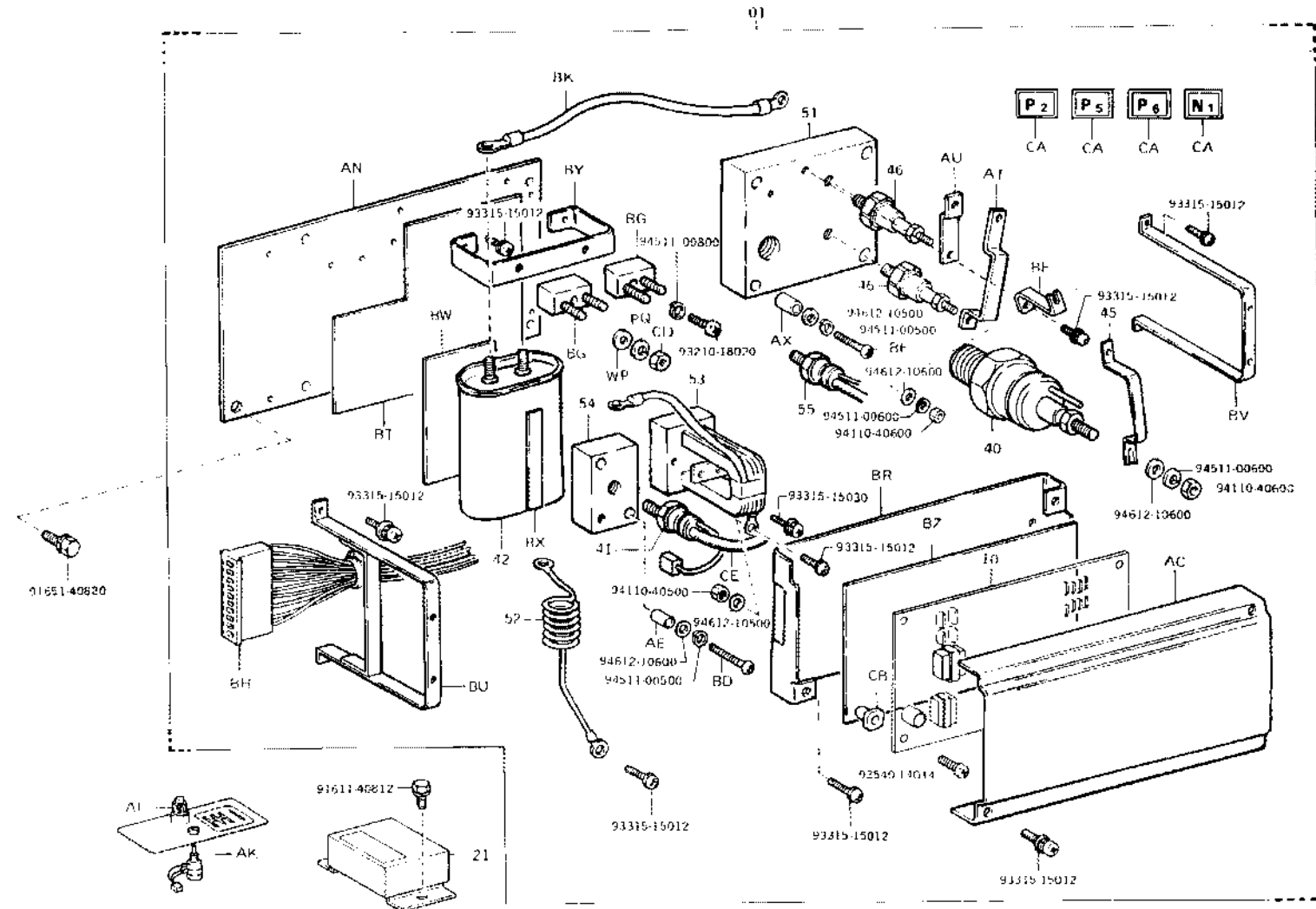

FIG. 2401 CONTROL PANEL

2401

STM (20D, 35D, 45D)



# 2401

PART NAME CODE	PART NAME	QTY
2401-01	PANEL ASSY, DRIVE CONTROL -----	1
2401-10	GENERATOR ASSY, SIGNAL -----	1
2401-21	OLA-CONTROLLER ASSY -----	1
2401-40	THYRISTOR, MAIN -----	1
2401-41	THYRISTOR, SUB -----	1
2401-42	CONDENSER -----	1
2401-45	SENSOR, CURRENT -----	1
2401-46	DIODE -----	2
2401-51	HEATSINK, NO.1 -----	1
2401-52	REACTOR (L1) -----	1
2401-53	REACTOR (L2) -----	1
2401-54	HEATSINK, NO.2 -----	1
2401-55	THYRISTOR, SUB -----	1
2401-AC	COVER -----	1
2401-AE	INSULATOR -----	2
2401-AJ	NUT -----	1
2401-AN	BASE -----	1
2401-AT	BAR -----	1
2401-AU	BAR -----	1
2401-AX	INSULATOR -----	4
2401-BD	SCREW -----	2
2401-BE	SCREW -----	4
2401-BF	BAR -----	1
2401-BG	HOLDER, TERMINAL -----	2
2401-BH	HARNES ASSY, WIRING -----	1
2401-BJ	BAR -----	2
2401-BK	WIRING -----	1
2401-BM	WASHER, SPRING -----	1
2401-BN	WASHER, PLATE -----	1
2401-BP	WASHER, PLATE -----	4
2401-BQ	WASHER, SPRING -----	4
2401-BR	BASE -----	1
2401-BT	SHEET -----	1
2401-BU	BRACKET SUB-ASSY, CAPACITOR -----	1
2401-BV	BRACKET SUB-ASSY -----	1
2401-BW	MAT -----	1
2401-BX	MAT -----	1
2401-BY	BRACKET SUB-ASSY, TERMINAL -----	1
2401-BZ	SHEET -----	1
2401-CA	PLATE, NAME -----	1
2401-CB	GROMMET -----	4
2401-CC	PLATE -----	1
2401-CD	NUT -----	4
2401-CE	SLEEVE -----	1
2401-CF	MAT -----	1

FIG. 2402 CONTACTOR PANEL

2402

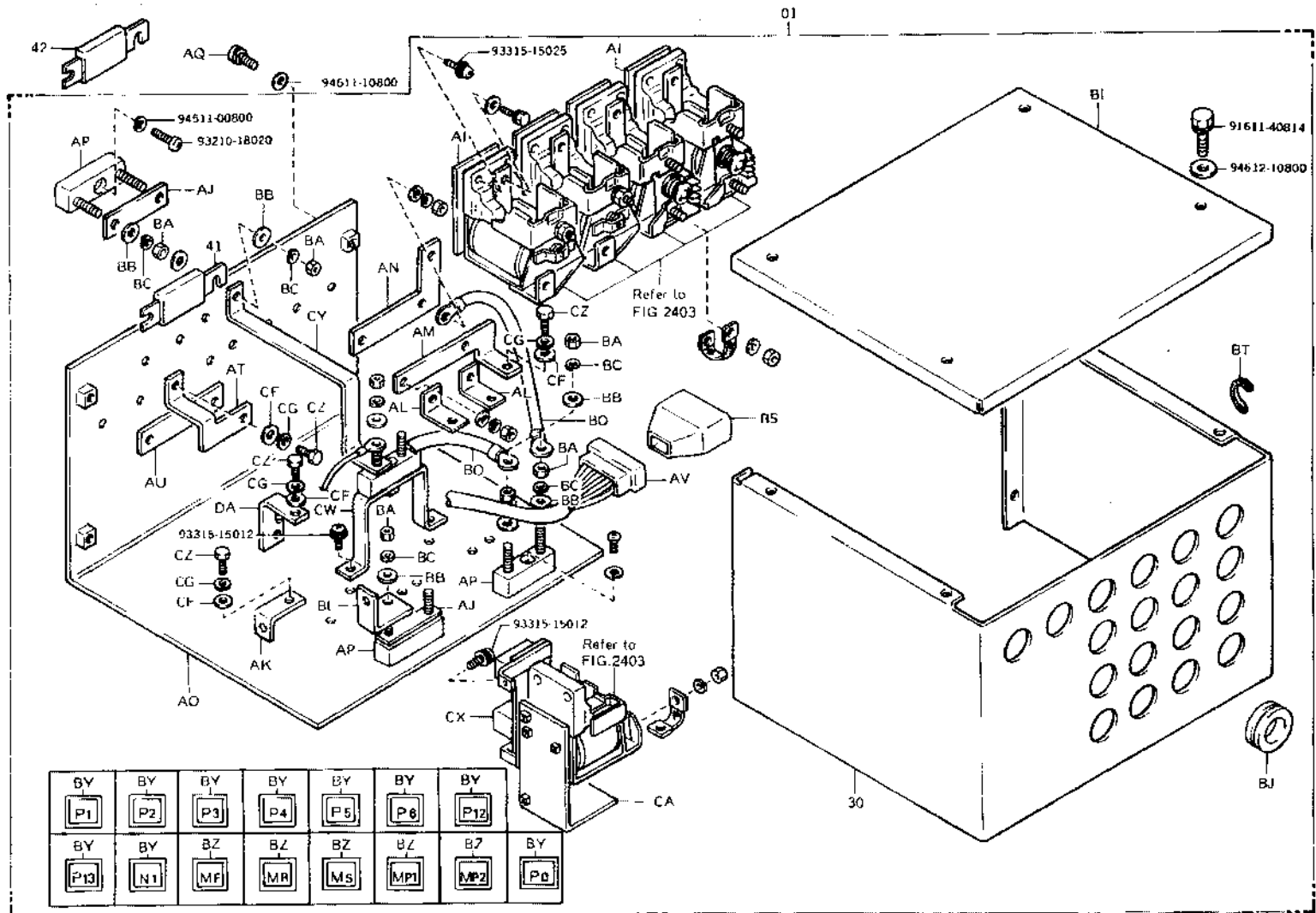
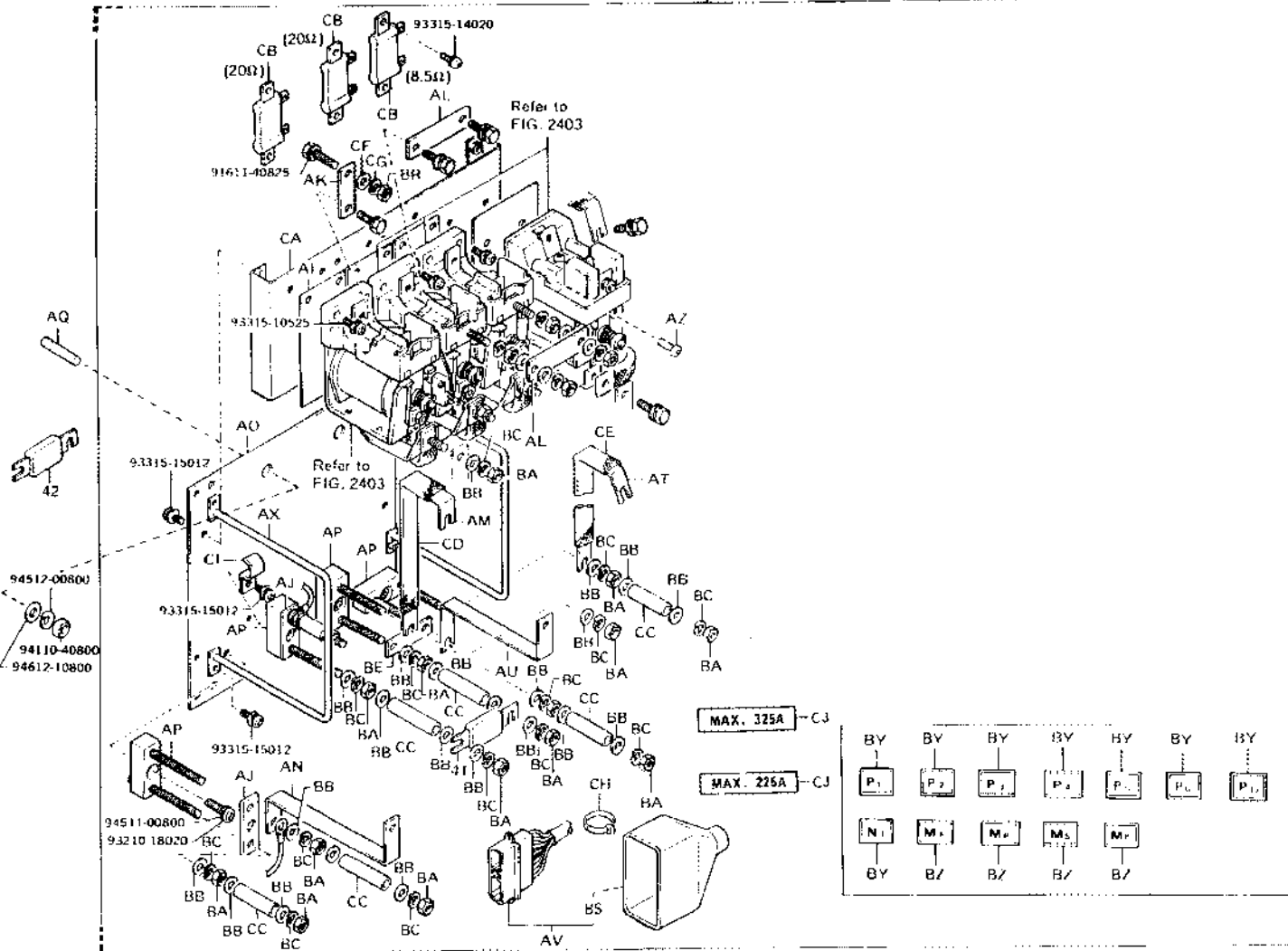

FIG. 2402 CONTACTOR PANFL

# 2402

HSP, STM (UL-E)

01





# 2402

PART NAME CODE	PART NAME	QTY
2402-01	PANEL ASSY, CONTACTOR -----	1
2402-30	COVER SUB-ASSY, CONTACTOR -----	1
2402-41	FUSE (F1) -----	1
2402-42	FUSE (F2) -----	1
2402-A1	INSULATOR -----	2
2402-AJ	BAR -----	2
2402-AK	BAR -----	1
2402-AL	BAR -----	2
2402-AM	BAR -----	1
2402-AN	BAR -----	1
2402-AO	BASE -----	1
2402-AP	HOLDER, TERMINAL -----	4
2402-AQ	STUD -----	2
2402-AT	BAR -----	1
2402-AU	BAR -----	1
2402-AV	HARNES ASSY, WIRING -----	1
2402-AX	HANDLE -----	2
2402-AZ	SCREW -----	2
2402-BA	NUT -----	15
2402-BB	WASHER -----	24
2402-BC	WASHER, SPRING -----	15
2402-BE	BAR -----	1
2402-BI	COVER, UPPER -----	1
2402-BJ	BUSHING -----	18
2402-BD	WIRING -----	1
2402-BR	NUT -----	1
2402-BS	BOOT -----	1
2402-BT	BUSH -----	1
2402-BY	PLATE, TERMINAL NUMBER -----	1
2402-BZ	PLATE, NAME -----	1
2402-CA	PLATE SUB-ASSY, CONTACTOR -----	1
2402-CB	RESISTOR SUB-ASSY -----	1- 2
2402-CC	SPACER -----	7
2402-CU	SLEEVE -----	1
2402-CF	SLEEVE -----	1
2402-CF	WASHER, PLATE -----	1
2402-CG	WASHER, SPRING -----	1
2402-CJ	PLATE, FUSE -----	1
2402-CW	PLATE SUB-ASSY, TERMINAL -----	1
2402-CX	BOARD, PUMP -----	1
2402-CY	BAR -----	1
2402-CZ	BDLT -----	7
2402-DA	BAR -----	1

FIG. 2403 CONTACTOR ASSY

2403

(FOR MEIDEN P/S MOTOR)

(FOR ND P/S MOTOR)

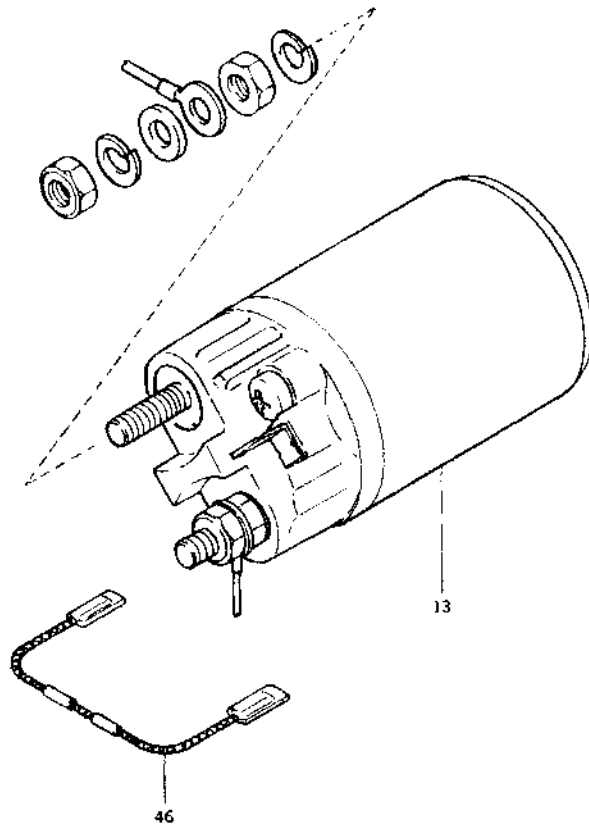
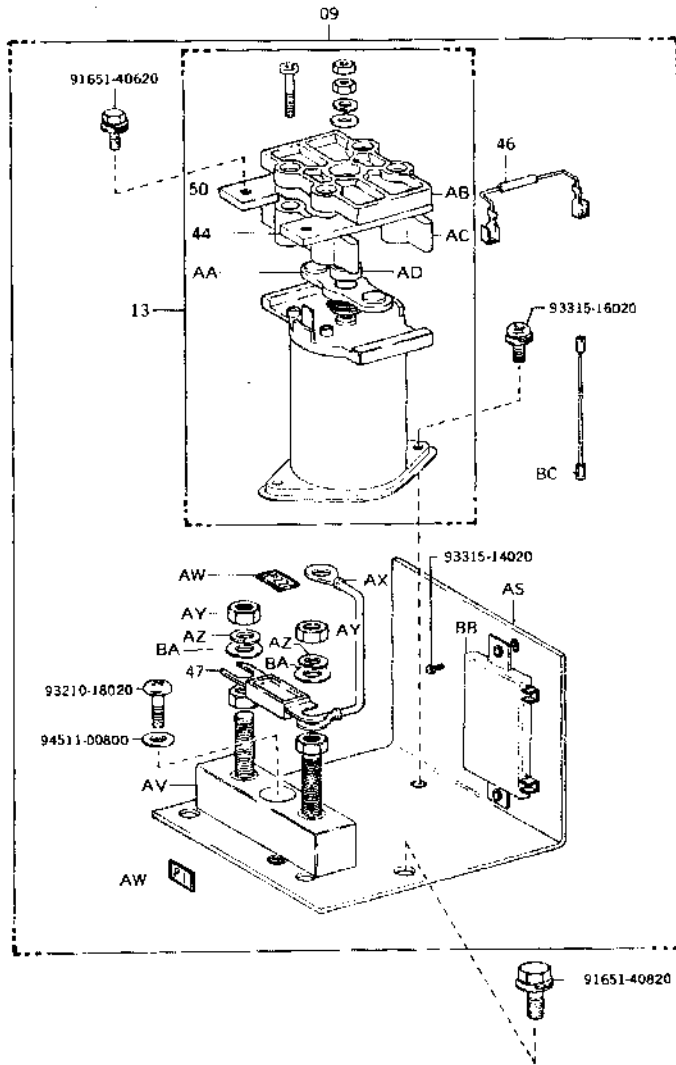

2403-010

2403-006

FIG. 2403 CONTACTOR ASSY

2403

[DRIVE]

[SHORT]

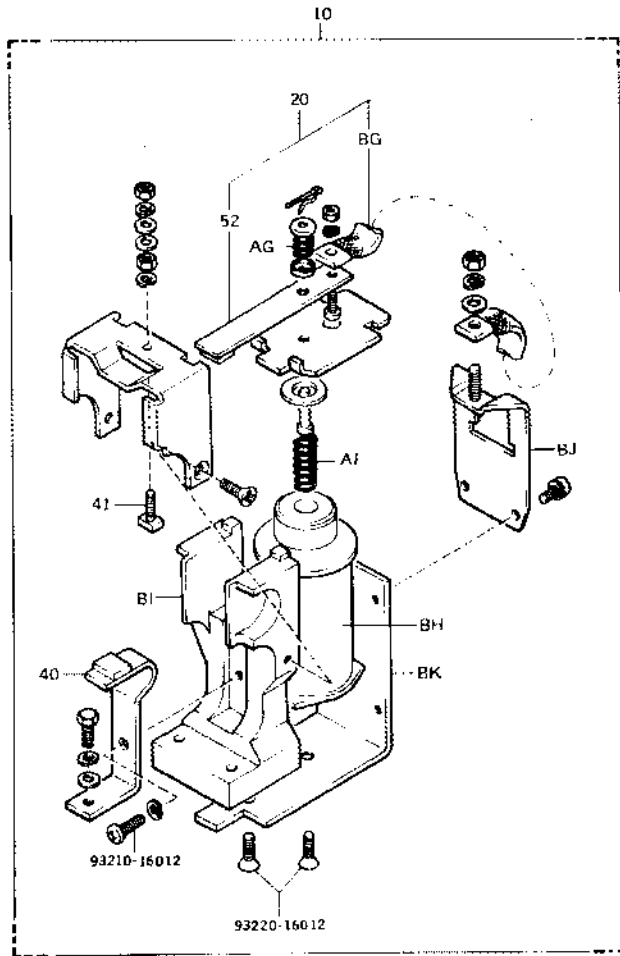

2403-019

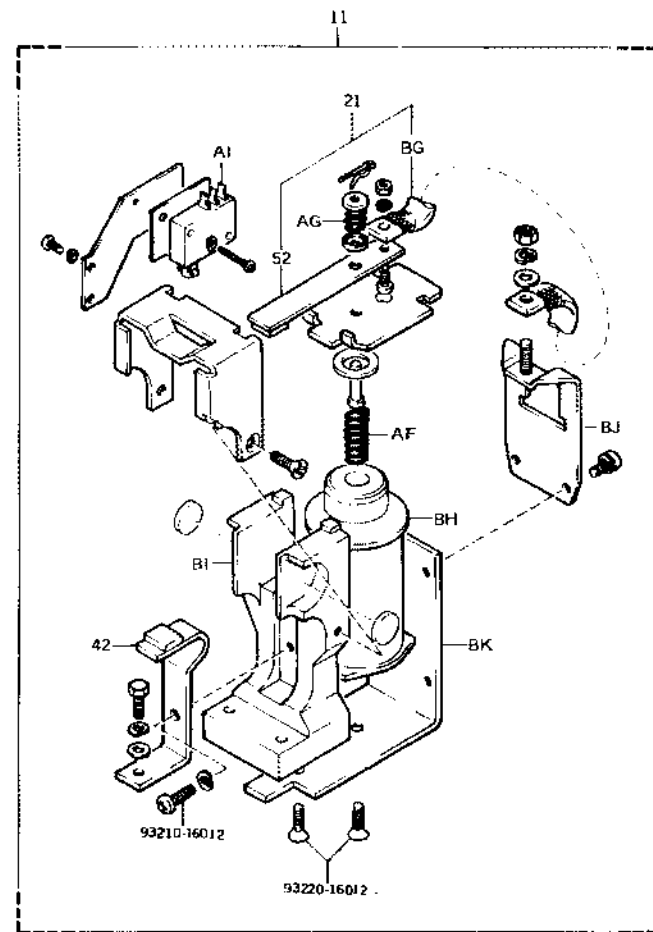

2403-020

FIG. 2403 CONTACTOR ASSY

2403

(PUMP)

HSP, STM (UL-E)

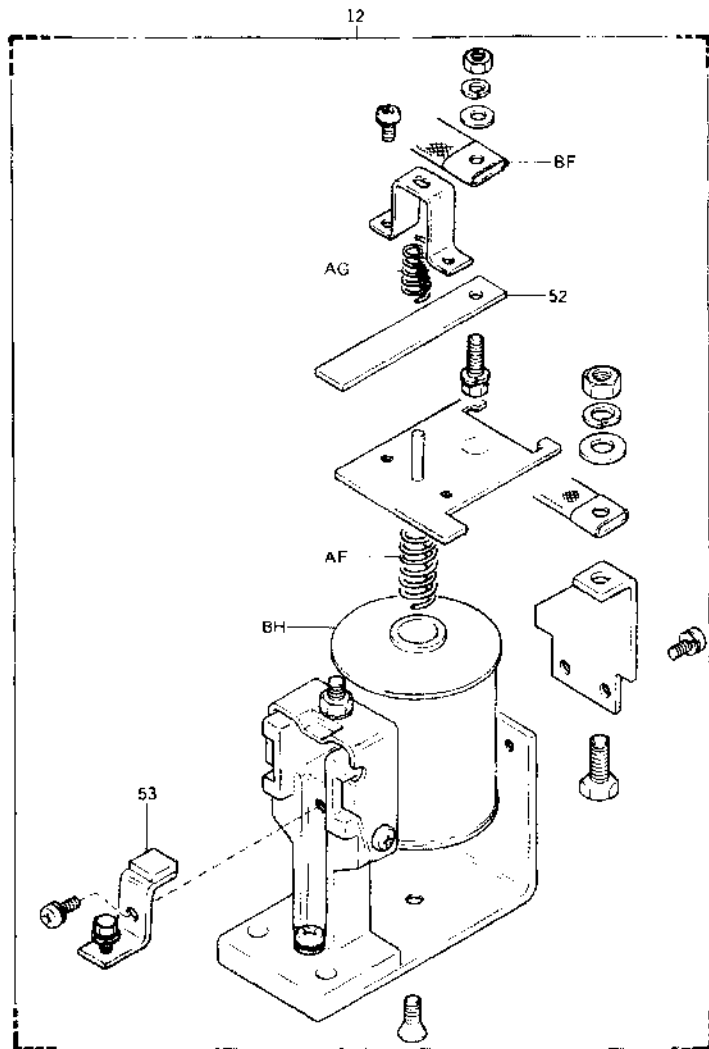

2403-01B

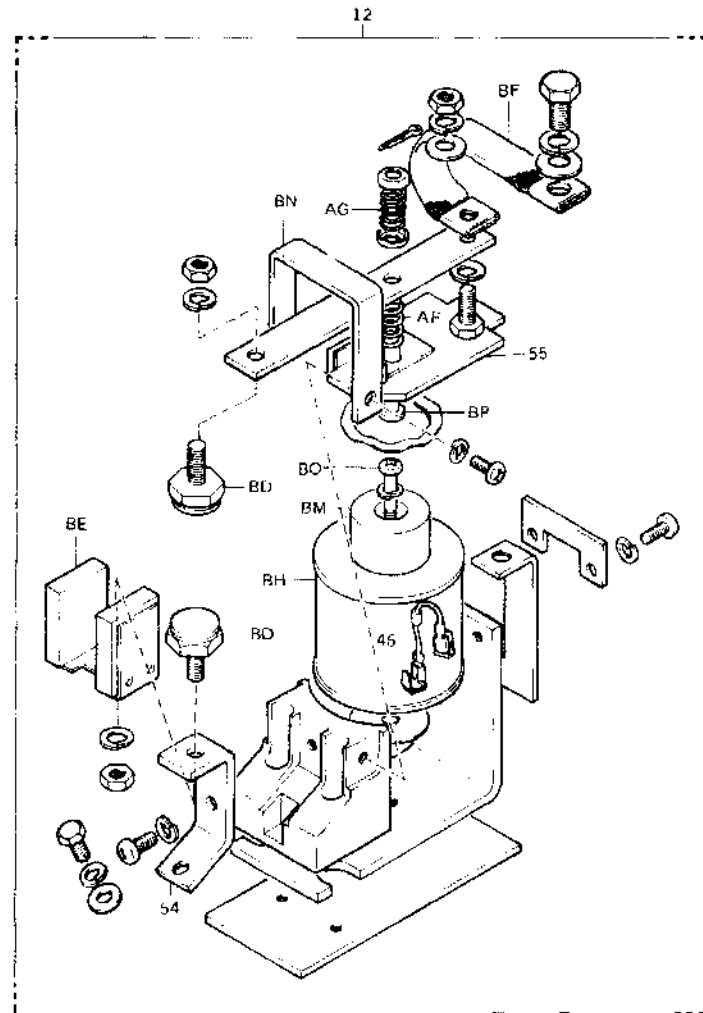

2403-01C

# 2403

PART NAME CODE	PART NAME	QTY
2403-09	CONTACTOR ASSY, POWER STEERING, LARGE -----	1
2403-10	CONTACTOR ASSY, DRIVE -----	2
2403-11	CONTACTOR ASSY, SHORT -----	1
2403-12	CONTACTOR ASSY, PUMP -----	1- 2
2403-13	CONTACTOR ASSY, POWER STEERING -----	1
2403-20	CONTACT SUB-ASSY, DRIVE MOVING -----	1
2403-21	CONTACT SUB-ASSY, SHORT MOVING -----	1
2403-40	CONTACT, DRIVE FIXED, NO.1 -----	1
2403-41	CONTACT, DRIVE FIXED, NO.2 -----	1
2403-42	CONTACT, SHORT FIXED -----	1
2403-44	CONTACT, POWER STEERING FIXED -----	1
2403-46	DISC -----	1
2403-47	FUSE (F3) -----	1
2403-50	CONTACT, POWER STEERING -----	1
2403-52	CONTACT, MOVING -----	1
2403-53	CONTACT, STATIONARY -----	1
2403-54	POST, CONTACT, A -----	1
2403-55	ARMATURE -----	1
2403-AA	MOVING, CONTACT -----	1
2403-AB	COVER -----	1
2403-AC	POLE -----	2
2403-AD	BUSHING, STEPPED, NO.1 -----	2
2403-AF	SPRING, NO.1 -----	1
2403-AG	SPRING, NO.2 -----	1
2403-AI	SWITCH, MICRO -----	1
2403-AS	BASE -----	1
2403-AV	HOLDER, TERMINAL -----	1
2403-AW	PLATE, TERMINAL NUMBER -----	1
2403-AX	WIRING SUB-ASSY -----	1
2403-AY	NUT -----	4
2403-AZ	WASHER, SPRING -----	4
2403-BA	WASHER, PLATE -----	6
2403-BB	RESISTOR SUB-ASSY -----	1
2403-BC	WIRING -----	1
2403-BD	CONTACT -----	2
2403-BE	BARRIER -----	1
2403-BF	WIRING -----	1
2403-BG	WIRE, LEAD -----	1
2403-BH	COIL -----	1
2403-BI	INSULATOR -----	1
2403-BJ	SUPPORT -----	1
2403-BK	FRAME -----	1
2403-BM	CORE -----	1
2403-BN	STOPPER -----	1
2403-BO	SCREW -----	1
2403-BP	PIN -----	1

FIG. 2413 CIRCUIT BREAKER

2413

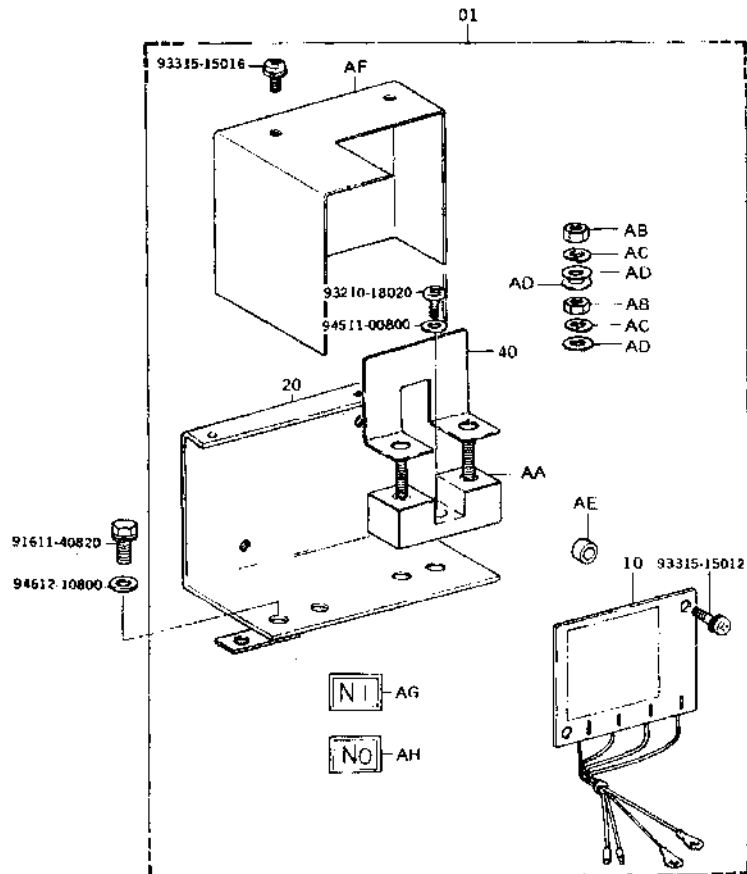

2413-001

PART NAME CODE	PART NAME	QTY
2413-01	BREAKER ASSY, CIRCUIT -----	1
2413-10	BOARD ASSY, CIRCUIT -----	1
2413-20	BASE SUB-ASSY, BREAKER -----	1
2413-40	RESISTER -----	1
2413-AA	TERMINAL BLOCK, FUSE -----	1
2413-AB	NUT -----	4
2413-AC	WASHER, SPRING -----	4
2413-AD	WASHER, PLATE -----	8
2413-AE	SPACER -----	2
2413-AF	COVER -----	1
2413-AG	PLATE, TERMINAL NUMBER (NI) -----	1
2413-AH	PLATE, TERMINAL NUMBER (NO) -----	1

FIG. 2501 BATTERY

2501

(G.S)

(G.S.CENTRAL FILLING)

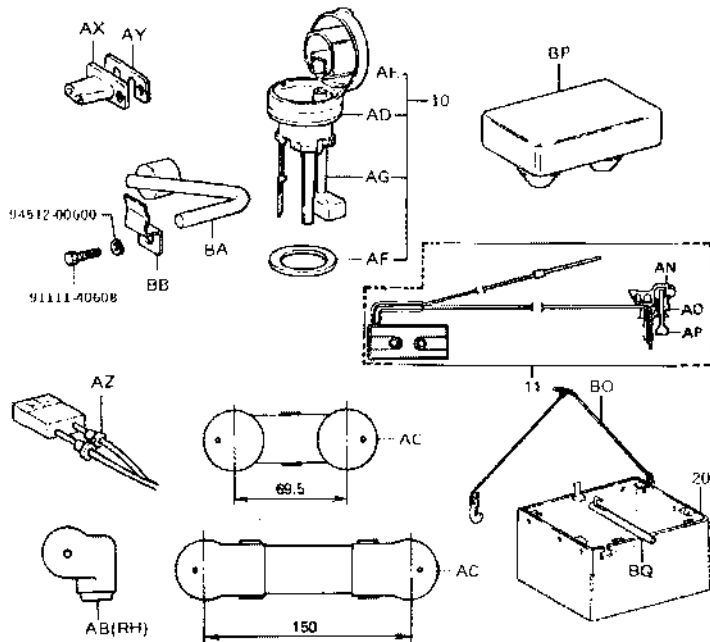
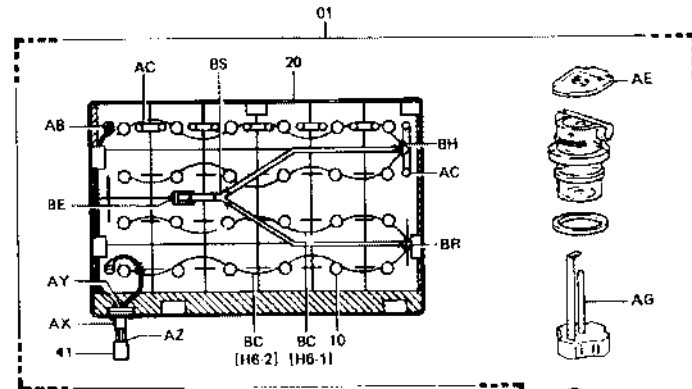
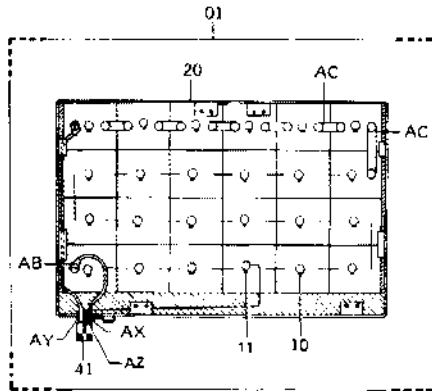

2501-040

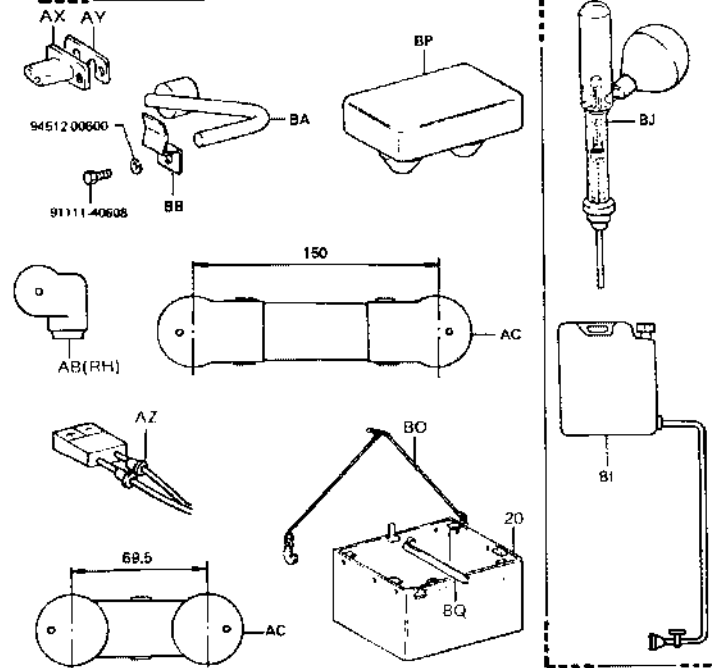

2501-041

FIG. 2501 BATTERY

2501

(YUASA)

(YUASA..CENTRAL FILLING)

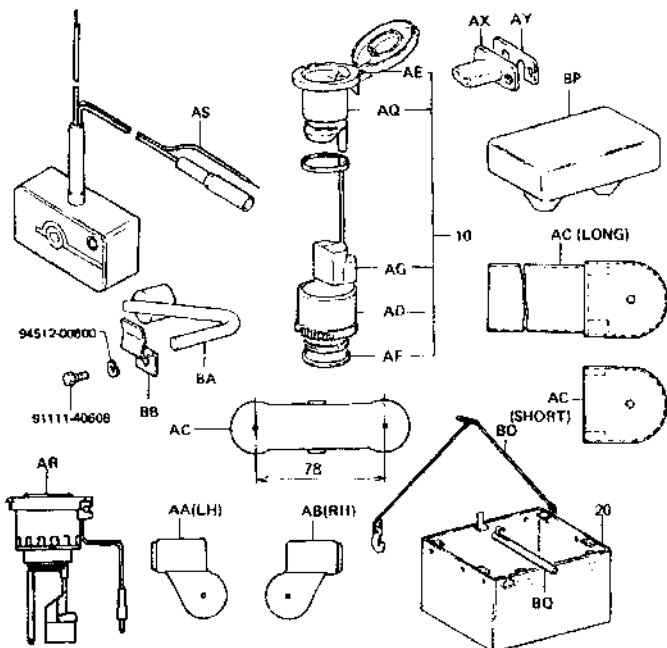
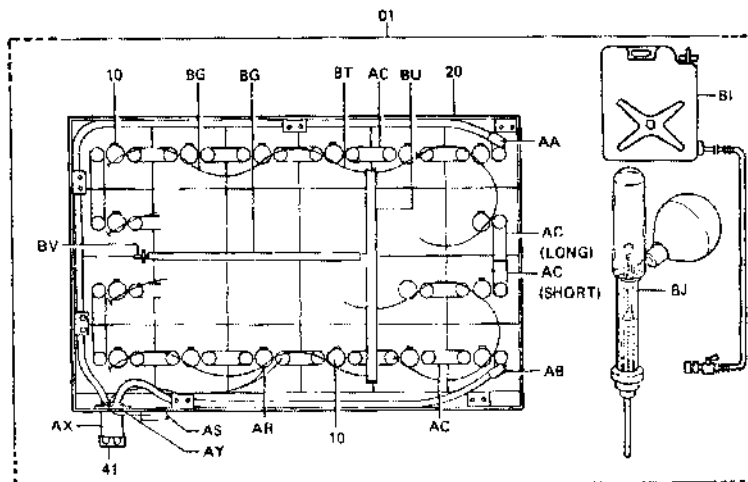
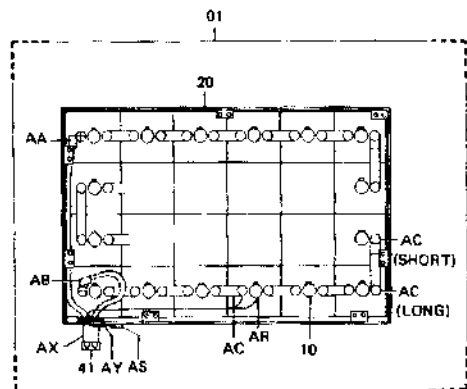

2501 042

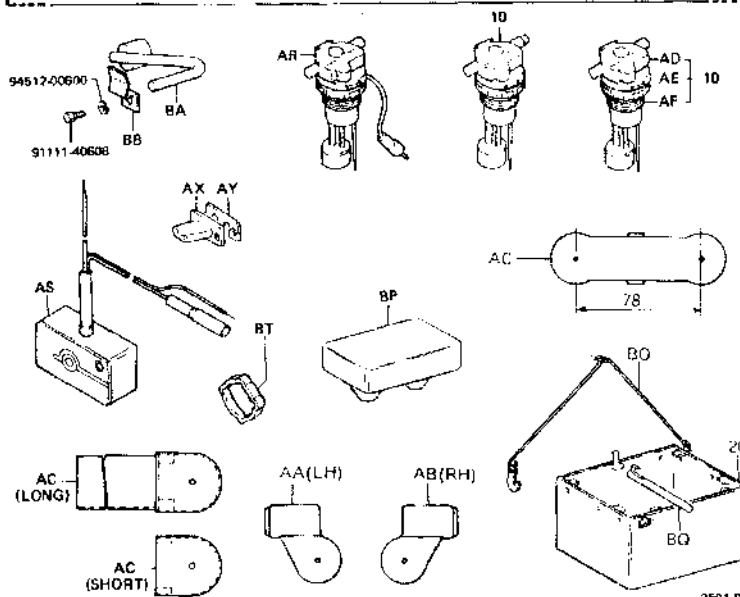

2501 043





FIG. 2501 BATTERY

**2501**

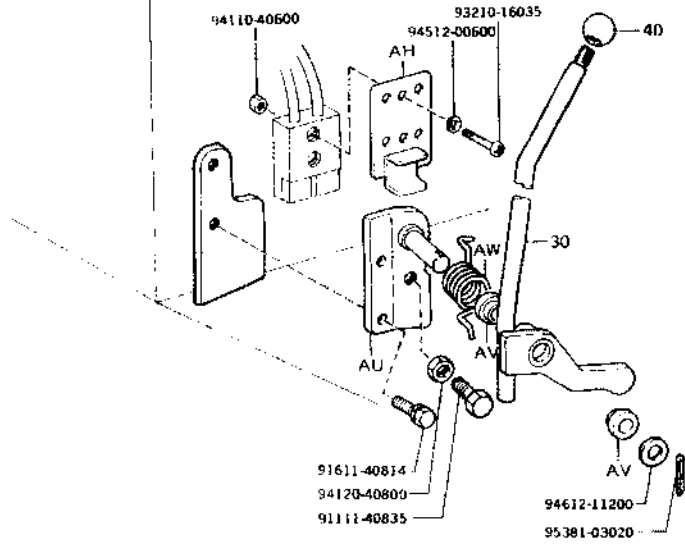

2501-005

PART NAME CODE	PART NAME	QTY
2501-01	BATTERY ASSY, W/CASE -----	1
2501-10	PLUG ASSY, VENT -----	6
2501-11	SENSOR ASSY, LEVEL -----	1
2501-20	CASE SUB-ASSY, BATTERY -----	1
2501-30	LEVER SUB-ASSY, EMERGENCY -----	1
2501-40	KNOB, EMERGENCY LEVER -----	1
2501-41	PLUG, BATTERY -----	1
2501-AA	COVER, TERMINAL, LH -----	1
2501-AB	COVER, TERMINAL, RH -----	1
2501-AC	COVER, TERMINAL -----	3
2501-AD	PLUG, VENT -----	17
2501-AE	CAP -----	17
2501-AF	PACKING -----	17
2501-AG	FLOAT -----	23
2501-AH	BRACKET -----	1
2501-AN	CAP -----	1
2501-AU	PACKING -----	1
2501-AP	FLOAT -----	1
2501-AQ	FLOAT, ROD SUPPORT -----	23
2501-AR	PLUG, VENT -----	1
2501-AS	ALARM -----	1
2501-AU	BRACKET SUB-ASSY, EMERGENCY LEVER -----	1
2501-AV	BUSHING -----	2
2501-AW	SPRING, TORSION -----	1
2501-AX	RUBBER, BATTERY CABLE -----	1
2501-AY	PLATE SUB-ASSY, BATTERY RUBBER -----	1
2501-AZ	BUSHING -----	2
2501-BA	STOPPER SUB-ASSY, BATTERY CASE -----	1
2501-BB	SPRING, BATTERY STOPPER -----	1
2501-BC	SCF3 UNIT -----	2
2501-BE	PIPE, WATER, SUPPLY -----	1
2501-BG	TUBE -----	1
2501-BH	WIRE -----	10
2501-BI	TANK -----	1
2501-BJ	METER ASSY, HYDRO SAILING -----	1
2501-BU	HANGER -----	2
2501-BP	RUBBER, CUSHION -----	7
2501-BQ	ROD SUB-ASSY, BATTERY STOPPER -----	1
2501-BR	PIPE, T -----	2
2501-B5	PIPE, 3-WAY -----	1
2501-BT	RING -----	48
2501-BU	PIPE -----	1
2501-BV	PIPE, INLET -----	1

FIG. 2512 BATTERY SEPARATE CHARGER

2512

(G.5)

(YUASA..AC200V)

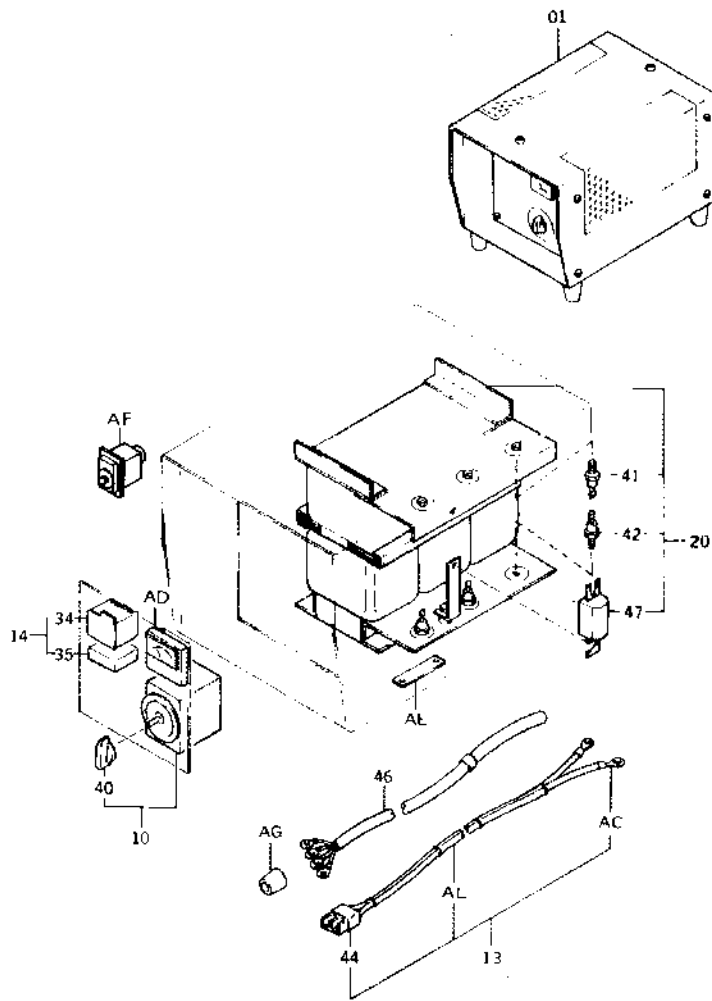

2512 011

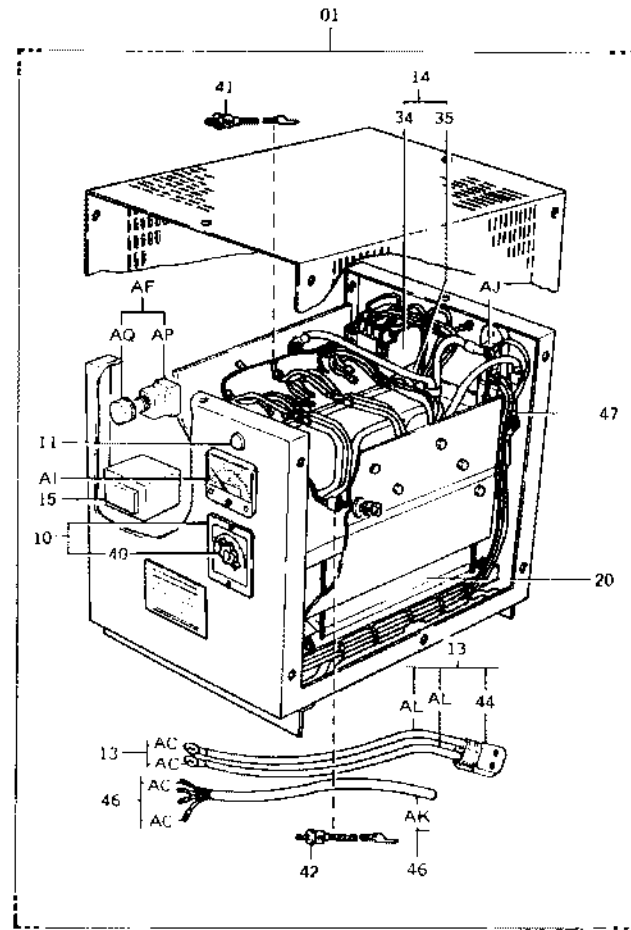

2512-012

FIG. 2512 BATTERY SEPARATE CHARGER

**2512**

(YUASA AC400V)

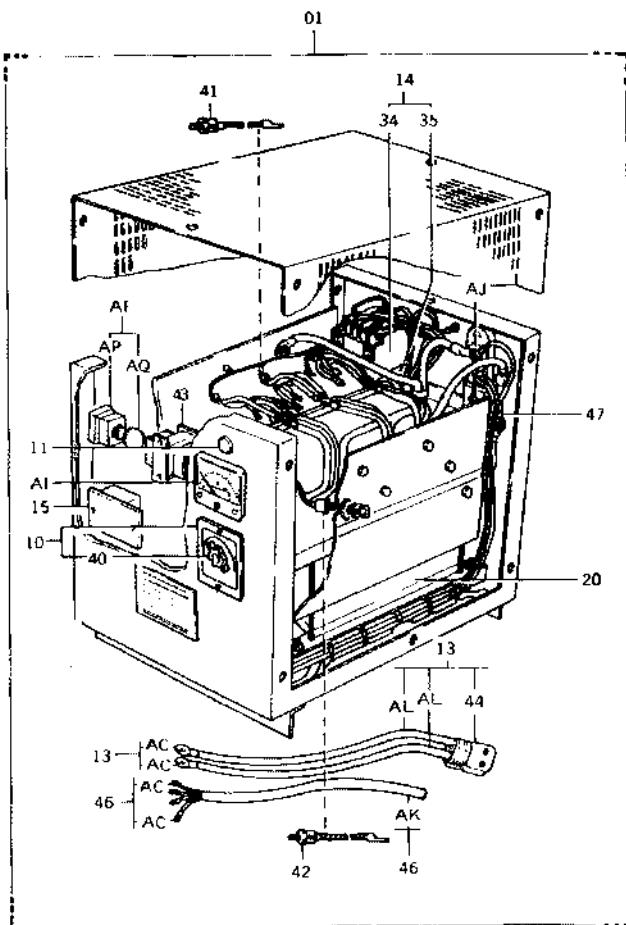

PART NAME CODE	PART NAME	QTY
2512-01	CHARGER ASSY, BATTERY SEPARATE	1
2512-10	TIMER ASSY	1
2512-11	LAMP ASSY, CHARGING	1
2512-13	CABLE ASSY, CHARGER (DC)	1
2512-14	SWITCH ASSY, MAGNET	1
2512-15	RELAY ASSY, VOLTAGE	1
2512-20	TRANSFORMER SUB-ASSY	1
2512-34	SWITCH SUB-ASSY, MAGNET	1
2512-35	RELAY SUB-ASSY, THERMAL	1
2512-40	HANDLE	1
2512-41	ELEMENT, SILICON, FORWARD	3
2512-42	ELEMENT, SILICON, REVERSE	3
2512-43	SUB-TRANSFORMER, CHARGER	1
2512-44	PLUG	1
2512-46	CABLE (AC)	1
2512-47	FUSE	1
2512-AC	TERMINAL	1
2512-AD	METER ASSY, AMPERE	1
2512-AE	SHUNT	1
2512-AF	TIMER ASSY, TOTAL	1
2512-AG	RUBBER	4
2512-AI	AMMETER	1
2512-AJ	SHUNT	1
2512-AK	CABLE	1
2512-AL	CABLE	1
2512-AP	TIMER SUB-ASSY	1
2512-AQ	SOCKET (FOR TIMER)	1

2512-013

FIG. 2611 ACCELERATOR

2611

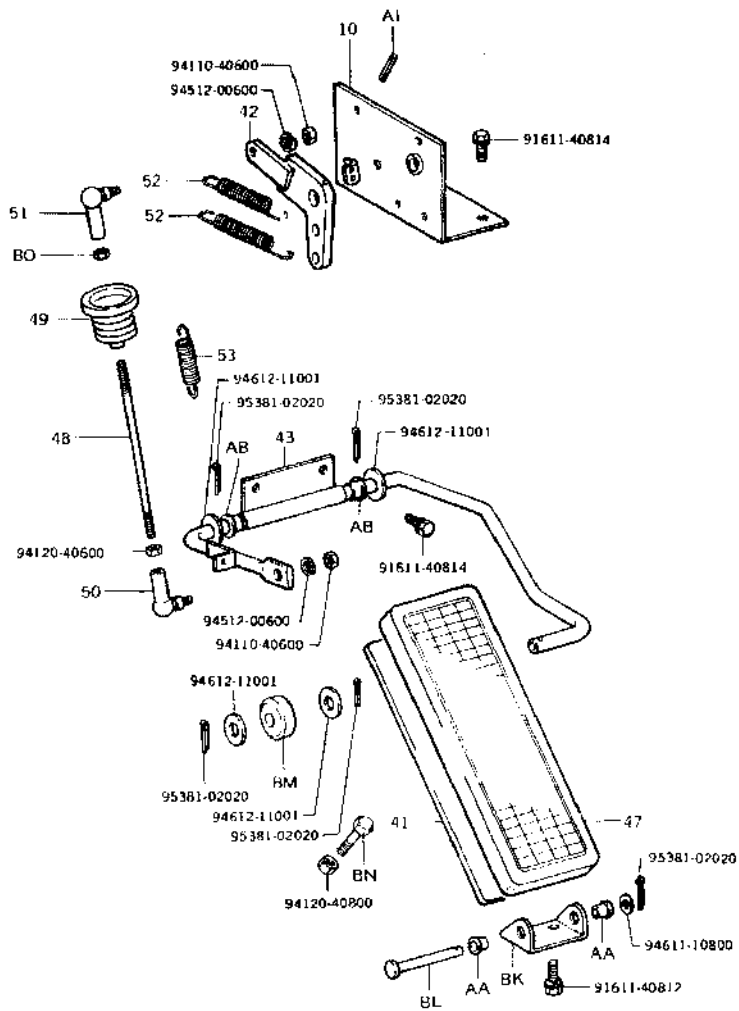

2611-012

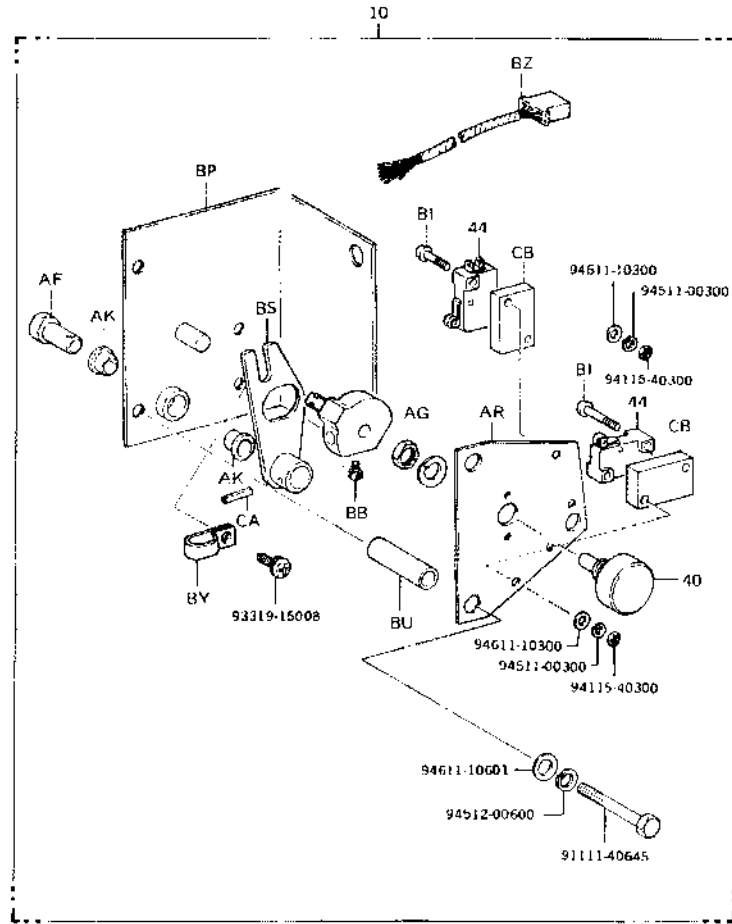

2611-011

# 2611

PART NAME CODE	PART NAME	QTY
2611-10	SWITCH ASSY, ACCELERATOR (PEDAL TYPE) -----	1
2611-40	VARI-OHM -----	1
2611-41	PEDAL, ACCELERATOR -----	1
2611-42	ARM, ACCELERATOR LINK -----	1
2611-43	ROD, ACCELERATOR PEDAL -----	1
2611-44	SWITCH, MICRO -----	2
2611-47	PAD, PEDAL -----	1
2611-48	ROD, ACCELERATOR LINK -----	1
2611-49	BOOT -----	1
2611-50	END, CONNECTING ROD, NO.1 -----	1
2611-51	END, CONNECTING ROD, NO.2 -----	1
2611-52	SPRING, TENSION, NO.1 -----	2
2611-53	SPRING, TENSION, NO.2 -----	1
2611-AA	BUSHING -----	2
2611-AB	BUSHING -----	2
2611-AF	SHAFT -----	1
2611-AG	CAM -----	1
2611-AI	PIN, SPRING -----	1
2611-AK	BUSHING -----	2
2611-AR	SUPPORT -----	1
2611-BB	SCREW -----	2
2611-B1	SCREW -----	4
2611-BK	BRACKET, PEDAL -----	1
2611-BL	PIN, W/WASHER -----	1
2611-BM	ROLLER, ACCELERATOR LINK -----	1
2611-BN	BOLT -----	1
2611-B0	NUT -----	1
2611-BP	HOLDER -----	1
2611-B5	LEVER, SWITCH -----	1
2611-BU	SPACER -----	3
2611-BY	CLAMP -----	1
2611-BZ	HARNES SUB-ASSY -----	1
2611-CA	PIN, SPRING -----	1
2611-CB	PLATE -----	2

FIG. 3305 GEAR CASE & GEAR

**3305**

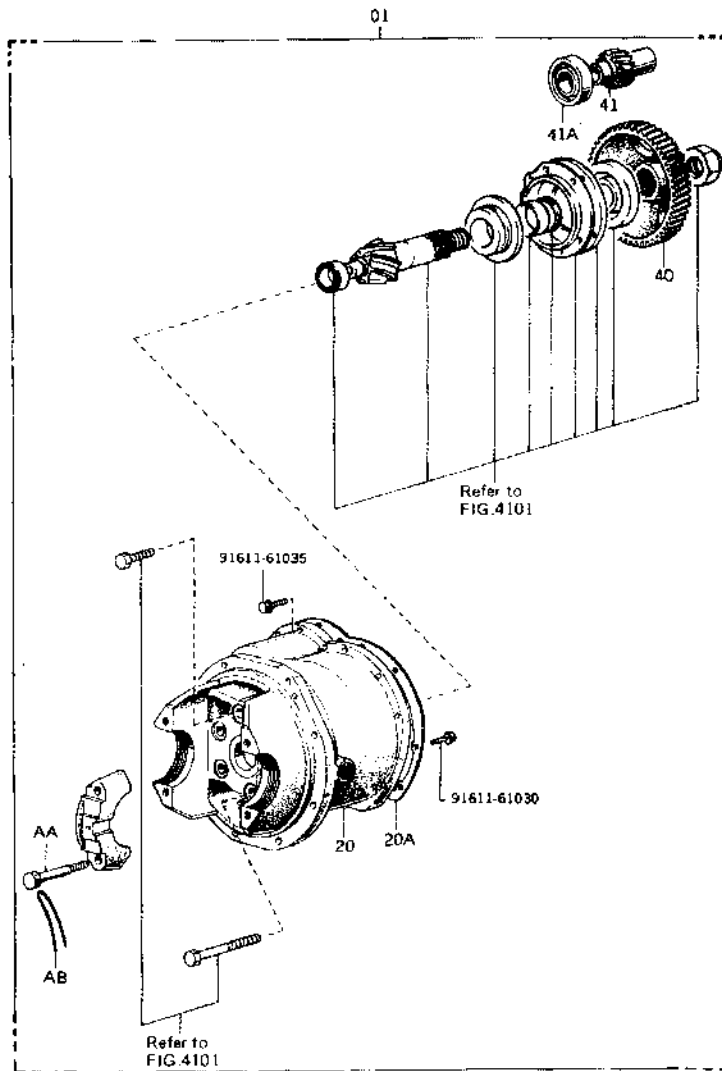

3305-001

PART NAME CODE	PART NAME	QTY
3305-01	CASE ASSY, GEAR -----	1
3305-20	CASE SUB-ASSY, GEAR -----	1
3305-20A	GASKET, GEAR CASE -----	1
3305-40	GEAR, OUTPUT -----	1
3305-41	GEAR, DRIVE -----	1
3305-41A	BEARING (FOR DRIVE GEAR) -----	1
3305-AA	BOLT -----	4
3305-AB	WIRE -----	2

(MAIN ) ( 12)

G208

FIG. 3310 CHANGE LEVER

# 3310

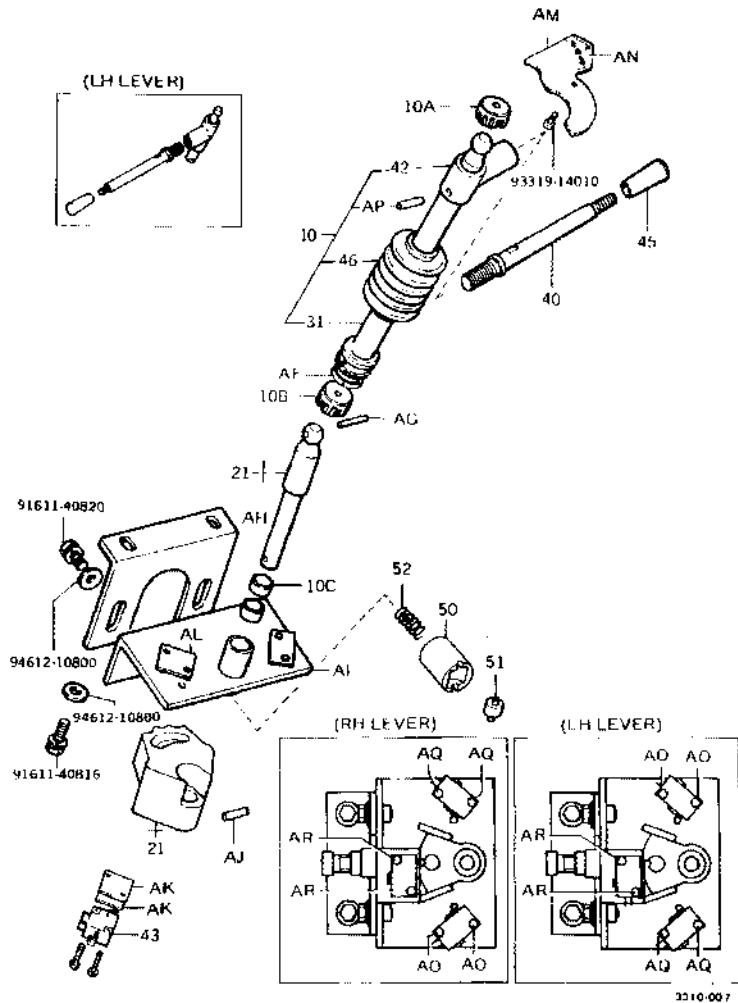

PART NAME CODE	PART NAME	QTY
3310-10	SHAFT ASSY, DIRECTION SWITCH	1
3310-10A	BUSH, NO.1 (FOR DIRECTION SWITCH SHAFT)	1
3310-10B	BUSH, NO.2 (FOR DIRECTION SWITCH SHAFT)	1
3310-10C	BUSH, NO.3 (FOR DIRECTION SWITCH SHAFT)	2
3310-21	CAM SUB-ASSY, DIRECTION SWITCH	1
3310-31	SHAFT SUB-ASSY, DIRECTION SWITCH	1
3310-40	LEVER	1
3310-42	HOUSING, CHANGE LEVER	1
3310-43	SWITCH, MICRO, NO.1	2- 3
3310-45	KNOB	1
3310-46	BOLT (FOR CONTROL SHAFT)	1
3310-50	HOUSING, ROLLER	1
3310-51	ROLLER	1
3310-52	SPRING, COMPRESSION	1
3310-A0	ACTUATOR	2
3310-AF	SPRING, PIN STOPPER	1
3310-AG	ROLLER, NEEDLE	1
3310-AH	STAY, DIRECTION SWITCH BRACKET	1
3310-AI	BRACKET SUB-ASSY, DIRECTION SWITCH	1
3310-AJ	PIN, SPRING	1
3310-AK	PLATE	4- 6
3310-AL	NUT, PLATE	2- 3
3310-AM	PLATE, CHANGE LEVER	1
3310-AN	PLATE, INDICATOR	1
3310-AO	SCREW	2
3310-AP	PIN, SPRING	1
3310-AQ	SCREW	2
3310-AR	SCREW	2

FIG. 4101 DIFFERENTIAL

4101

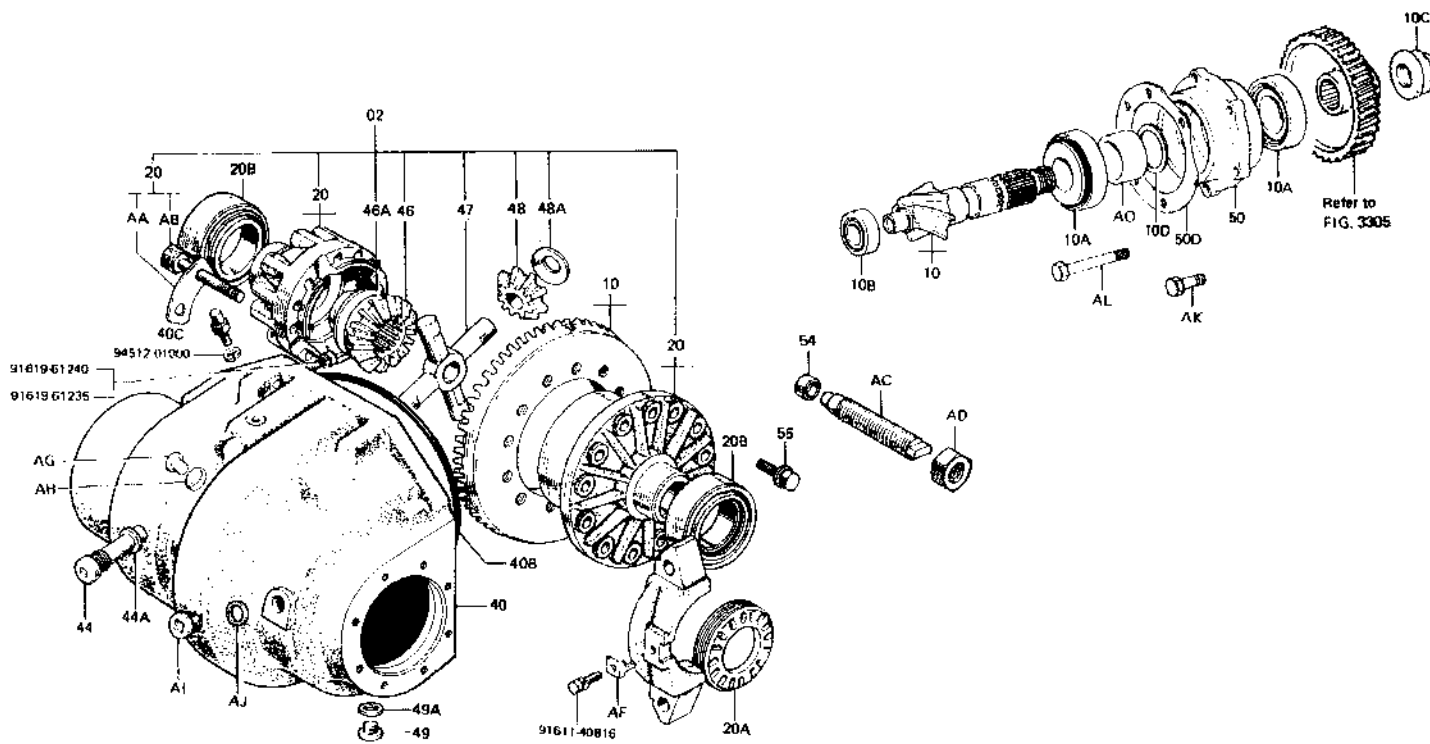



# 4101

PART NAME CODE	PART NAME	QTY
4101-02	CASE ASSY, DIFFERENTIAL -----	1
4101-10	RING GEAR & PINION SET, DIFFERENTIAL -----	1
4101-10A	BEARING, DRIVE PINION -----	2
4101-10B	BEARING, DRIVE PINION PILOT -----	1
4101-10C	NUT, LOCK -----	1
4101-10D	SHIM, BEARING PRELOAD ADJUST -----	99
4101-20	CASE SUB-ASSY, DIFFERENTIAL -----	1
4101-20A	NUT, ADJUSTING -----	2
4101-20B	BEARING, DIFFERENTIAL CASE -----	2
4101-40	HOUSING, DIFFERENTIAL -----	1
4101-40B	RING, O (FOR DIFFERENTIAL HOUSING) -----	1
4101-40C	PLUG, BREATHER (FOR DIFFERENTIAL HOUSING) ---	1
4101-44	PLUG (FOR INPUT SHAFT) -----	1
4101-44A	PACKING (FOR INPUT SHAFT PLUG) -----	1
4101-46	GEAR, SIDE -----	2
4101-46A	WASHER, SIDE GEAR THRUST -----	2
4101-47	SPIDER -----	1
4101-48	PINION -----	2
4101-48A	WASHER, PINION THRUST -----	2
4101-49	PLUG, DRAIN -----	1
4101-49A	GASKET, DRAIN -----	1
4101-50	RETAINER, DRIVE PINION BEARING -----	1
4101-500	SHIM, DIFFERENTIAL DRIVE PINION BLARING ---	99
4101-54	CAP, RING GEAR THRUST SCREW -----	1
4101-55	BOLT, RING GEAR SET -----	12
4101-AA	PLATE, BOLT LOCK -----	2
4101-AB	BOLT -----	12
4101-AC	SCREW, RING GEAR THRUST -----	1
4101-AD	NUT -----	1
4101-AF	LOCK, ADJUSTING -----	2
4101-AG	PLUG, W/HEAD STRAIGHT SCREW -----	1
4101-AH	GASKET -----	1
4101-AI	PLUG -----	1
4101-AJ	GASKET -----	1
4101-AK	BOLT -----	2
4101-AL	BOLT -----	4
4101-AO	SPACER, BEARING -----	1

FIG. 4201 FRONT AXLE SHAFT

4201

(DIVIDED RIM)

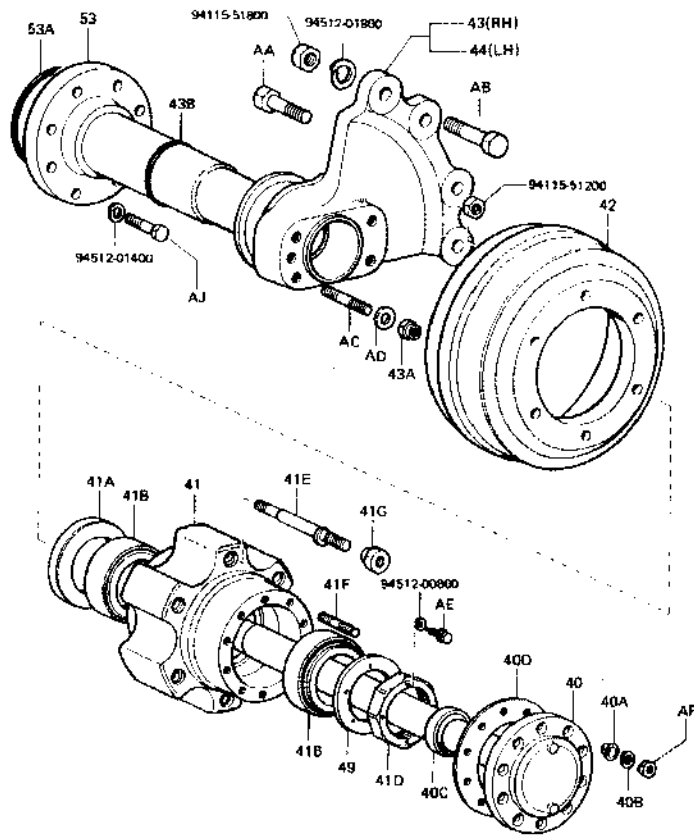

4201-015

(SIDE RING RIM)

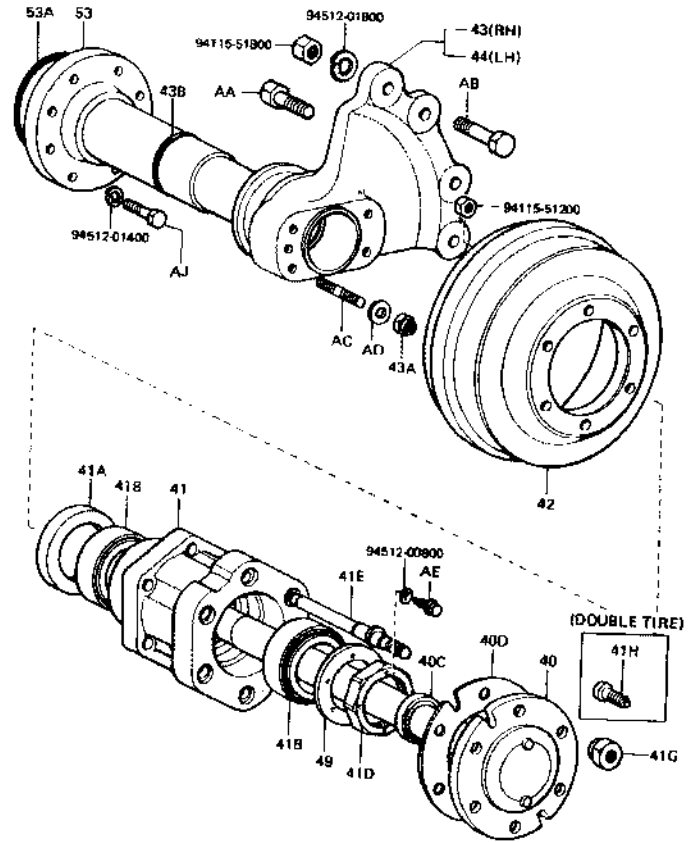

4201-002A

# 4201

PART NAME CODE	PART NAME	QTY
4201-40	SHAFT, FRONT AXLE -----	2
4201-40A	WASHER, CORN -----	20
4201-40B	WASHER, SPRING (FOR FRONT AXLE SHAFT) -----	20
4201-40C	SEAL, OIL (FOR FRONT AXLE SHAFT) -----	2
4201-40D	GASKET, FRONT AXLE SHAFT -----	2
4201-41	HUB, FRONT AXLE -----	2
4201-41A	SEAL, OIL (FOR FRONT AXLE HUB) -----	2
4201-41B	BEARING, NO.1 (FOR FRONT AXLE HUB) -----	4
4201-41D	NUT, BEARING LOCK -----	2
4201-41E	BOLT, HUB -----	12
4201-41F	BOLT, STUD (FOR FRONT AXLE SHAFT) -----	20
4201-41G	NUT, HUB -----	12
4201-41H	BOLT, DOUBLE WHEEL STOP -----	12
4201-42	DRUM, BRAKE -----	2
4201-43	BRACKET, FRONT AXLE, RH -----	1
4201-43A	NUT, BRAKE SET SELF -----	10
4201-43B	RING, O (FOR FRONT AXLE BRACKET) -----	2
4201-44	BRACKET, FRONT AXLE, LH -----	1
4201-49	PLATE, LOCK NUT -----	2
4201-53	HOUSING, FRONT AXLE -----	2
4201-53A	RING, O (FOR FRONT AXLE HOUSING) -----	2
4201-AA	BOLT -----	4
4201-AB	BOLT, BRACKET SET -----	4
4201-AC	BOLT, STUD BRAKE SET -----	10
4201-AD	WASHER, CO SPRING -----	10
4201-AE	BOLT -----	2
4201-AJ	BOLT -----	16
4201-AP	NUT -----	20

FIG. 4301 REAR AXLE & TIE-ROD

# 4301

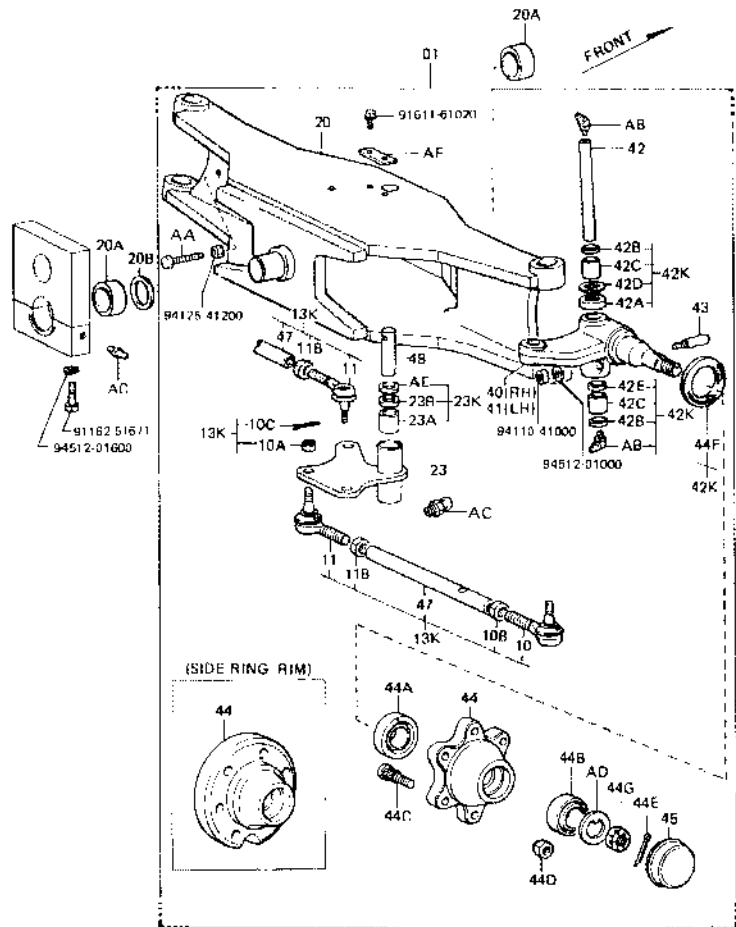

4301 001H

PART NAME CODE	PART NAME	QTY
4301-01	AXLE ASSY, RR -----	1
4301-10	END ASSY, TIE-ROD, NO.1 -----	2
4301-10A	NUT, CASTLE (FOR TIE-ROD END) -----	4
4301-10B	NUT (RH THREADS) -----	2
4301-10C	PIN, COTTER (FOR TIE-ROD END) -----	4
4301-11	END ASSY, TIE-ROD, NO.2 -----	2
4301-11B	NUT (LH THREADS) -----	2
4301-13K	TIE-ROD KIT -----	2
4301-20	BEAM SUB-ASSY, REAR AXLE -----	1
4301-20A	BUSH, REAR AXLE BEAM -----	2
4301-20B	SHIM, REAR AXLE BEAM -----	1
4301-23	BELLCRANK SUB-ASSY, STEERING -----	1
4301-23A	BEARING (FOR STEERING BELLCRANK) -----	2
4301-23B	SEAL, OIL (FOR STEERING BELLCRANK) -----	2
4301-23K	SEAL KIT, BELLCRANK PIN -----	1
4301-40	KNUCKLE, STEERING, RH -----	1
4301-41	KNUCKLE, STEERING, LH -----	1
4301-42	PIN, STEERING KNUCKLE KING -----	2
4301-42A	BEARING, STEERING KNUCKLE THRUST -----	2
4301-42B	SEAL, OIL, NO.1 -----	4
4301-42C	BEARING, NEEDLE -----	4
4301-42D	SHIM, STEERING KNUCKLE -----	1
4301-42E	SEAL, OIL, NO.2 -----	2
4301-42K	SEAL KIT, KING PIN -----	2
4301-43	PIN, KING PIN LOCK -----	2
4301-44	HUB, REAR AXLE -----	2
4301-44A	BEARING, INNER -----	2
4301-44B	BEARING, OUTER -----	2
4301-44C	BOLT, HUB -----	12
4301-44D	NUT, HUB -----	12
4301-44E	PIN, REAR AXLE COTTER -----	2
4301-44F	SEAL, OIL (FOR REAR AXLE HUB) -----	2
4301-44G	NUT, CASTLE (FOR REAR AXLE HUB) -----	2
4301-45	CAP, REAR AXLE HUB -----	2
4301-47	TIE-ROD -----	2
4301-48	PIN, BELLCRANK -----	1
4301-AA	BOLT -----	2
4301-AB	FITTING, GREASE -----	4
4301-AC	FITTING, GREASE -----	3
4301-AD	WASHER, DRAW -----	2
4301-AE	SHIM -----	2
4301-AF	PLATE, STOPPER -----	1

FIG. 4401 FRONT WHEEL & TIRE (SINGLE)

4401

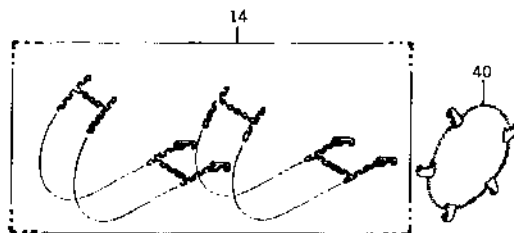
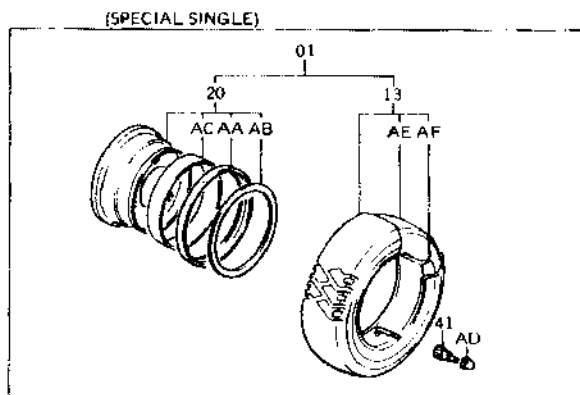
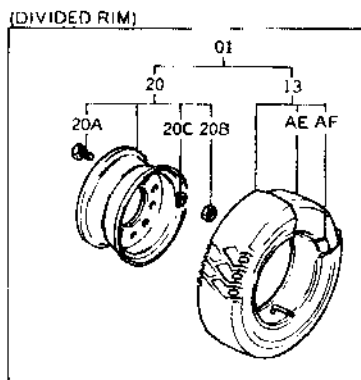

4401-01B

PART NAME CODE	PART NAME	QTY
4401-01	WHEEL ASSY -----	2
4401-13	TIRE ASSY -----	2
4401-14	CHAIN ASSY, TIRE -----	1
4401-20	WHEEL SUB-ASSY, DISC -----	2
4401-20A	BOLT (FOR DISC WHEEL SET) -----	12
4401-20B	NUT (FOR DISC WHEEL SET) -----	12
4401-20C	WASHER, SPRING (FOR DISC WHEEL SET) -----	12
4401-40	BAND, CHAIN -----	2
4401-41	EXTENSION, WHEEL TUBE VALVE -----	2
4401-AA	FLANGE, SIDE -----	2
4401-AB	RING, LOCK -----	2
4401-AC	BAND, BEND SHEET -----	2
4401-AD	CAP, VALVE -----	2
4401-AE	TUBE SUB-ASSY -----	2
4401-AF	FLAP -----	2

FIG. 4402 FRONT WHEEL & TIRE (DOUBLE)

**4402**

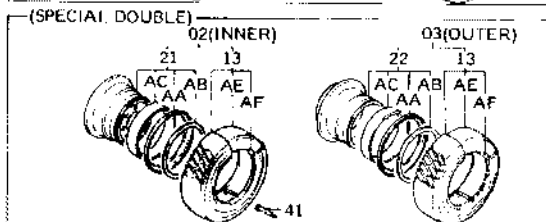
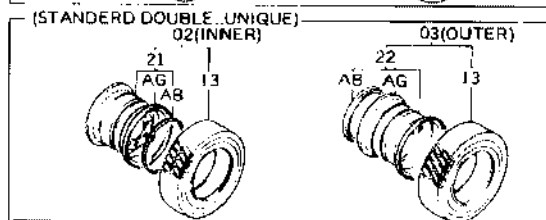
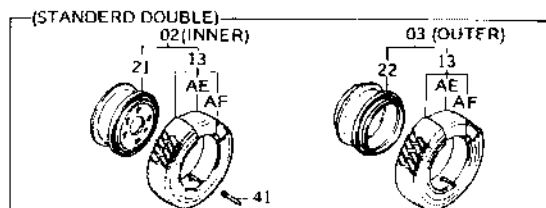

4402-006

PART NAME CODE	PART NAME	QTY
4402-02	WHEEL ASSY, INNER -----	2
4402-03	WHEEL ASSY, OUTER -----	2
4402-13	TIRE ASSY -----	2
4402-14	CHAIN ASSY, TIRE -----	1
4402-21	WHEEL SUB-ASSY, DISC, INNER -----	2
4402-22	WHEEL SUB-ASSY, DISC, OUTER -----	2
4402-40	BAND, CHAIN -----	2
4402-41	EXTENSION, WHEEL TUBE VALVE -----	2
4402-AA	FLANGE, SIDE -----	4
4402-AB	RING, LOCK -----	4
4402-AC	BAND, BEND SHEET -----	4
4402-AE	TUBE SUB-ASSY -----	4
4402-AF	FLAP -----	4
4402-AG	RING, SIDE -----	4

FIG. 4403 REAR WHEEL & TIRE

**4403**

(DIVIDED RIM)

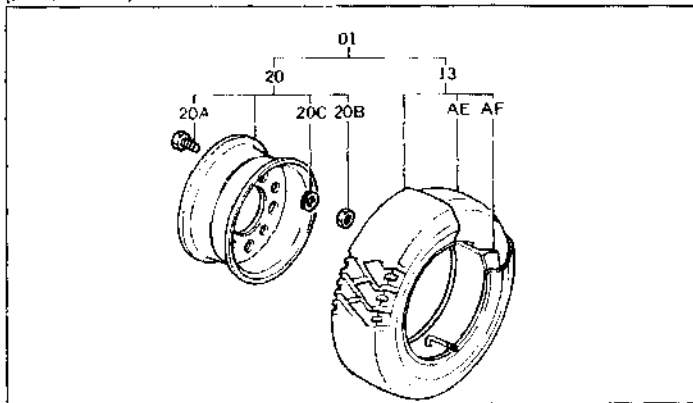

(SIDE RING RIM)

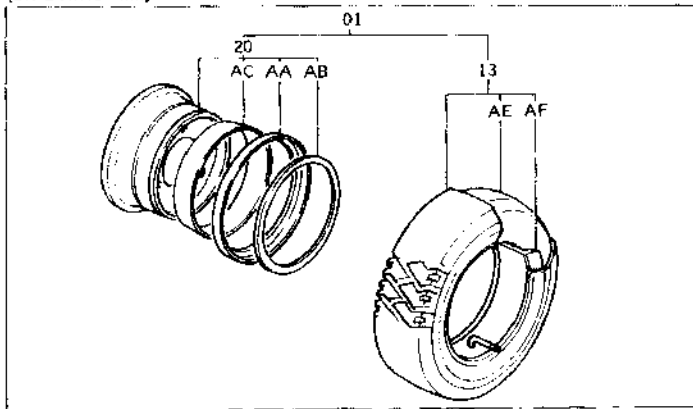

4403 005

PART NAME CODE	PART NAME	QTY
4403-01	WHEEL ASSY -----	2
4403-13	TIRE ASSY -----	2
4403-20	WHEEL SUB-ASSY, DISC -----	2
4403-20A	BOLT, DISC WHEEL SET -----	12
4403-20B	NUT, WHEEL SET -----	12
4403-20C	WASHER, WHEEL SET -----	12
4403-AA	FLANGE, SIDE -----	2
4403-AB	RING, LOCK -----	4
4403-AC	BAND, BEND SHEET -----	2
4403-AE	TUBE SUB-ASSY -----	2
4403-AF	FLAP -----	2

FIG. 4501 STEERING WHEEL

**4501**

(STD), (UL-E)

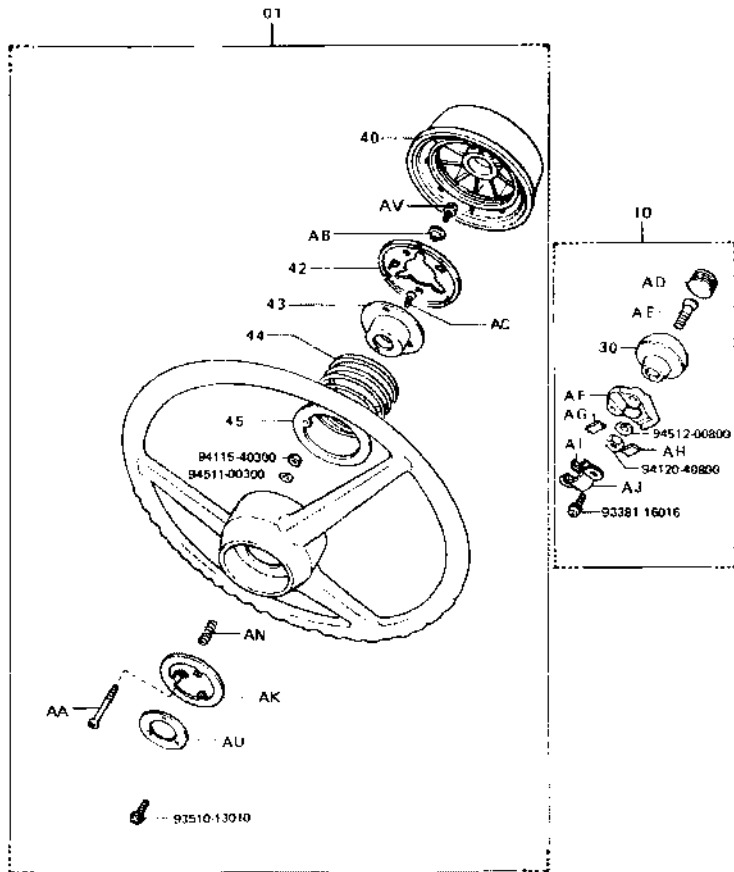

4501-004

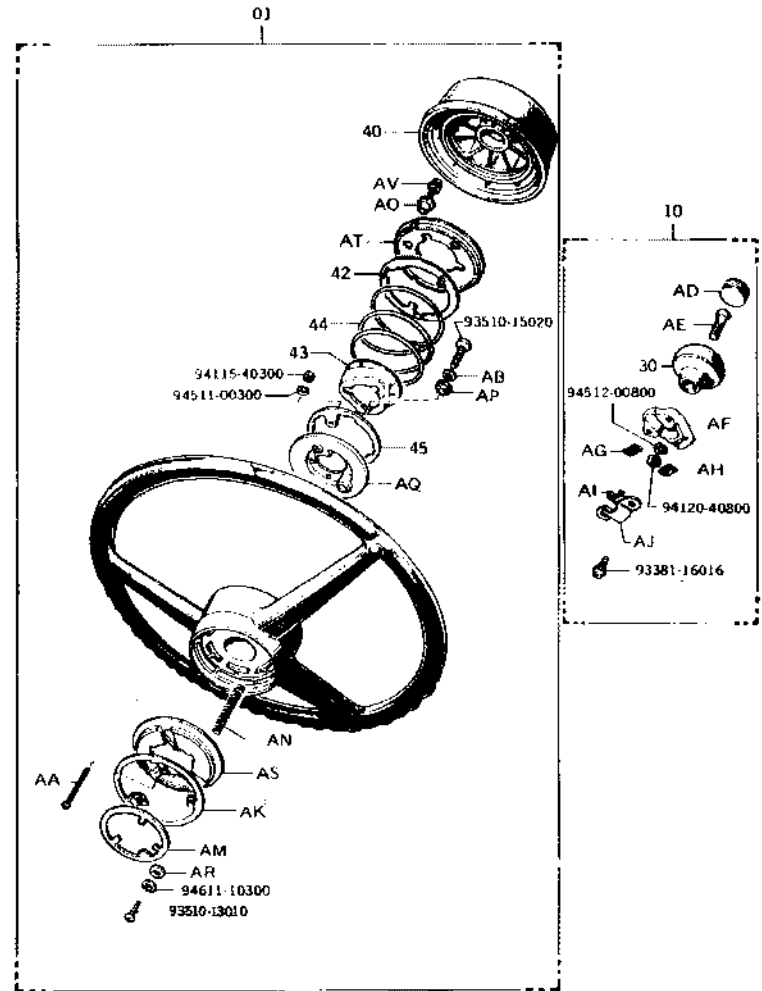

4501-006



**4501**

PART NAME CODE	PART NAME	QTY
4501-01	WHEEL ASSY, STEERING -----	1
4501-10	KNOB ASSY, STEERING WHEEL -----	1
4501-30	KNOB SUB-ASSY, STEERING WHEEL -----	1
4501-40	BUTTON, HORN -----	1
4501-42	PLATE, HORN CONTACT -----	1
4501-43	SEAT, HORN CONTACT -----	1
4501-44	SPRING, HORN -----	1
4501-45	PLATE, LEAD -----	1
4501-AA	SCREW -----	1
4501-AB	WASHER -----	3
4501-AC	SCREW -----	3
4501-AD	CAP, STEERING WHEEL -----	1
4501-AE	BOLT, STEERING WHEEL KNOB SET -----	1
4501-AF	BRACKET, STEERING WHEEL KNOB -----	1
4501-AG	SEAT, STEERING WHEEL KNOB BRACKET -----	1
4501-AH	SEAT, STEERING WHEEL KNOB BRACKET -----	1
4501-AI	SEAT, WHEEL KNOB SET PLATE -----	1
4501-AJ	PLATE, STEERING WHEEL KNOB SET -----	1
4501-AK	RING, HORN CONTACT NO.1 -----	1
4501-AN	SRRING, LEAD -----	1
4501-AD	SPACER, NO.3 -----	3
4501-AP	SPACER, NO.5 -----	3
4501-AQ	SPACER, NO.5 -----	1
4501-AR	SPACER, NO.4 -----	2
4501-AS	SPACER, NO.1 -----	1
4501-AT	PLATE, HORN BUTTON SET -----	1
4501-AU	RING, HORN CONTACT NO.2 -----	1
4501-AV	SCREW -----	3

FIG. 4502 STEERING POST

# 4502

(M/S)

(M/S)

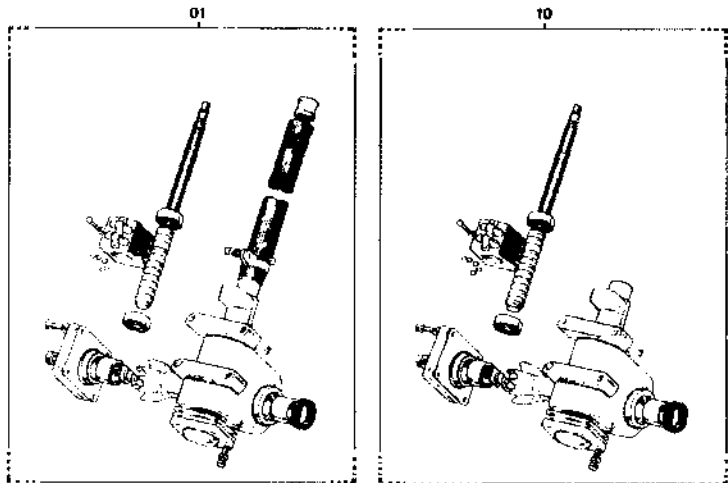

4502-022

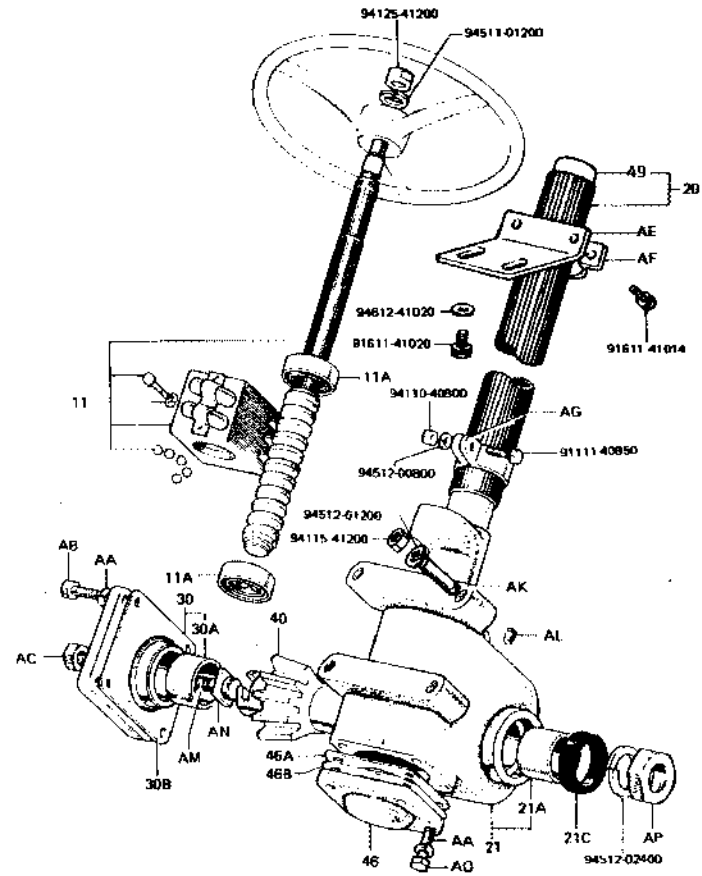

4502-023

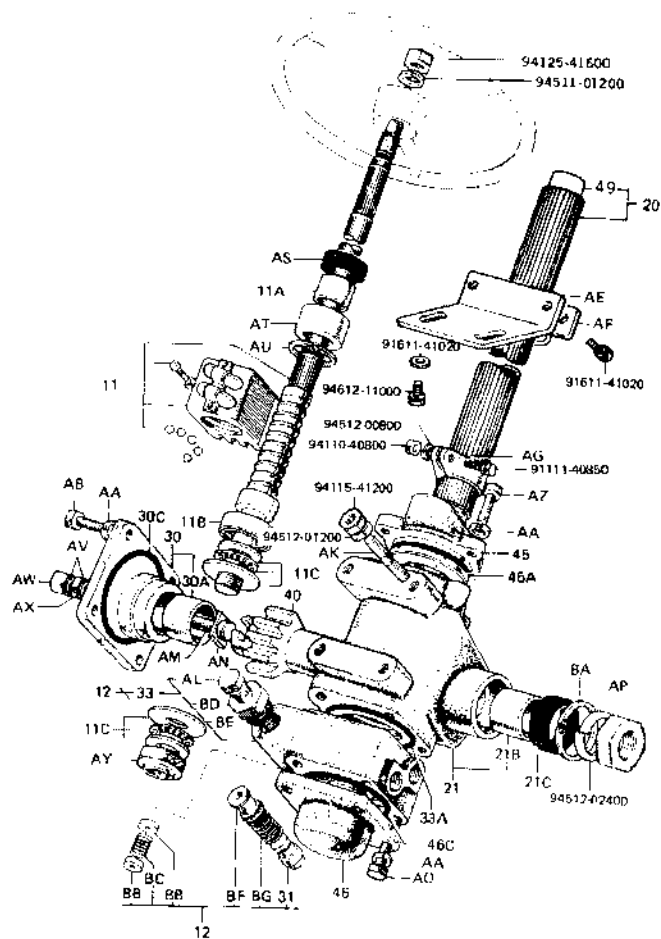
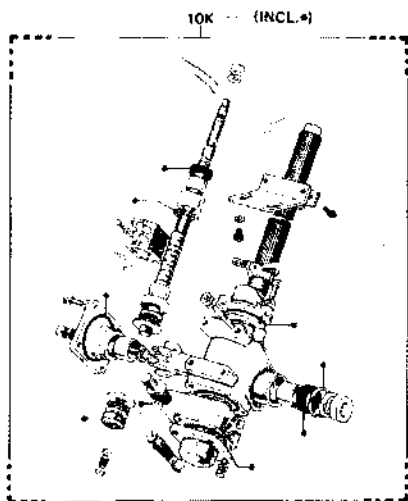
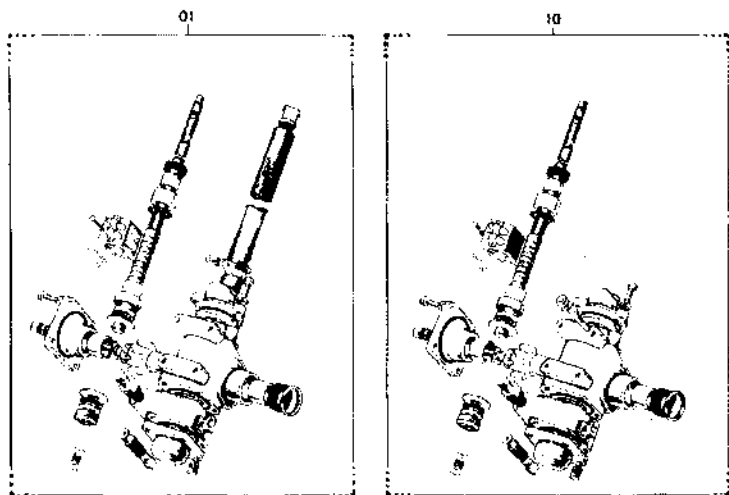

FIG. 4502 STEERING POST

4502

(P/S)

(P/S)



4502-021

4502 020

# 4502

PART NAME CODE	PART NAME	QTY
4502-01	POST ASSY, STEERING -----	1
4502-10	GEAR ASSY, STEERING -----	1
4502-10K	GEAR O/H KIT, STEERING -----	1
4502-11	BALL SCREW SET -----	1
4502-11A	BEARING, NO.1 (FOR BALL SCREW SET) -----	1
4502-11B	BEARING, NO.2 (FOR BALL SCREW SET) -----	1
4502-11C	BEARING, THRUST (FOR BALL SCREW SET) -----	2
4502-12	BODY ASSY, VALVE -----	1
4502-20	JACKET SUB-ASSY, MAST -----	1
4502-21	BOX SUB-ASSY, STEERING GEAR -----	1
4502-21A	BUSH, SECTOR SHAFT, NO.1 -----	1
4502-21B	BEARING, NO.1 (FOR SECTOR SHAFT) -----	1
4502-21C	SEAL, OIL (FOR SECTOR SHAFT) -----	1
4502-30	COVER SUB-ASSY, SIDE -----	1
4502-30A	BUSH, SECTOR SHAFT, NO.2 -----	1
4502-30B	PACKING, SIDE COVER -----	1
4502-30C	RING, O (FOR SIDE COVER) -----	1
4502-31	VALVE SET, RELIEF -----	1
4502-33	BODY SET, VALVE -----	1
4502-33A	RING, O (FOR VALVE BODY SET) -----	2
4502-40	SHAFT, SECTOR -----	1
4502-45	COVER, TOP -----	1
4502-45A	RING, O (FOR TOP COVER) -----	1
4502-46	COVER, END -----	1
4502-46A	PACKING, END COVER -----	1
4502-46B	SHIM (FOR END COVER) -----	99
4502-46C	RING, O (FOR END COVER) -----	1
4502-49	GROMMET, STEERING COLUMN (INSULATOR) -----	1
4502-AA	WASHER, SPRING -----	8-11
4502-AB	BOLT -----	4
4502-AC	NUT -----	1
4502-AC	STAY SUB-ASSY, STEERING -----	1
4502-AF	CLAMP -----	1
4502-AG	CLAMP, STEERING COLUMN, LOWER -----	1
4502-AK	BOLT, STUD -----	4
4502-AL	PLUG, OIL -----	1
4502-AM	BOLT, ADJUSTING -----	1
4502-AN	PLATE, ADJUSTING -----	1
4502-AG	BOLT -----	4
4502-AP	NUT -----	1
4502-AS	SEAL, OIL -----	1
4502-AY	CELLAR -----	1
4502-AU	RING, SNAP -----	1
4502-AV	PACKING -----	2
4502-AW	NUT -----	1
4502-AX	NUT -----	1
4502-AY	NUT, LOCK -----	1
4502-AZ	BOLT -----	3
4502-HA	RING, SNAP -----	1
4502-BB	SEAT -----	8
4502-BC	SPRING -----	4
4502-BD	STOPPER, BALANCE PISTON -----	1
4502-BE	RING, O -----	1

(MAIN ) ( 21)

G208

PART NAME CODE	PART NAME	QTY
4502-BF	VALVE SUB-ASSY, RELIEF -----	1
4502-BG	SPRING, BALANCE PISTON -----	1

(MAIN ) ( 22)

G208

FIG. 4507 DRAG LINK & STEERING PIPING

4507

(M/S)

(P/S)

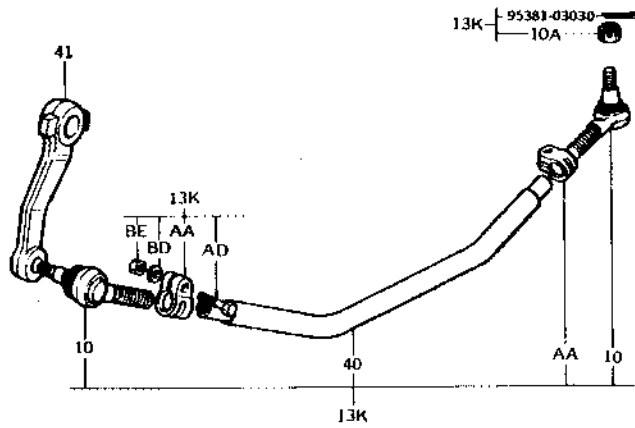

4507 010

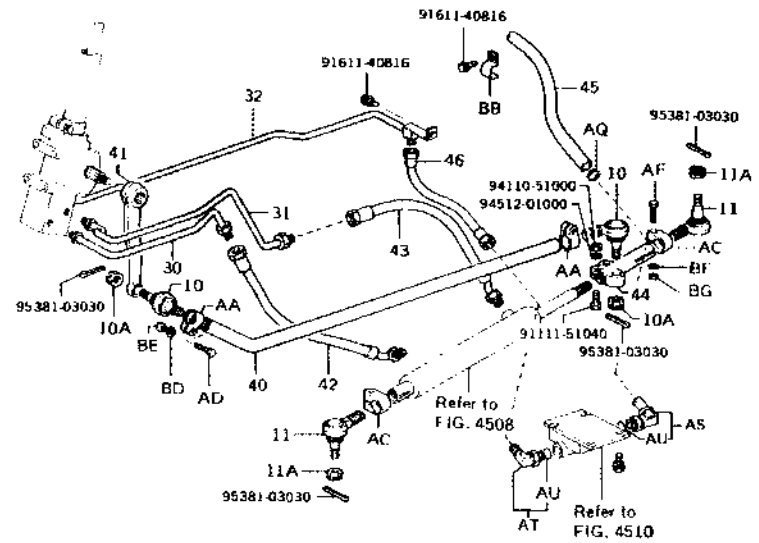

4507 011

**4507**

PART NAME CODE	PART NAME	QTY
4507-10	END ASSY, DRAG LINK -----	2
4507-10A	NUT, CASTLE (FOR DRAG LINK END) -----	2
4507-11	END ASSY, POWER CYLINDER -----	2
4507-11A	NUT, CASTLE (FOR POWER CYLINDER END) -----	2
4507-13K	ROD KIT, DRAG LINK -----	1
4507-30	PIPE SUB-ASSY, NO.1 (STEERING TO CYLINDER) -	1
4507-31	PIPE SUB-ASSY, NO.2 (STEERING TO CYLINDER) -	1
4507-32	PIPE SUB-ASSY (PUMP TO STEERING) -----	1
4507-40	ROD, DRAG LINK, NO.1 -----	1
4507-41	ARM, PITMAN -----	1
4507-42	HOSE, POWER CYLINDER, NO.1 -----	1
4507-43	HOSE, POWER CYLINDER, NO.2 -----	1
4507-44	END, POWER CYLINDER -----	1
4507-45	HOSE, POWER STEERING PUMP SUCTION -----	1
4507-46	HOSE, HIGH PRESSURE (PUMP TO STEERING) -----	1
4507-AA	CLAMP, END -----	2
4507-AD	BOLT -----	2
4507-AF	BOLT -----	2
4507-AQ	CLAMP -----	2
4507-AS	FITTING -----	1
4507-AT	FITTING -----	1
4507-AU	RING, O -----	2
4507-BB	CLAMP -----	1
4507-BD	WASHER, SPRING -----	2
4507-BE	NUT -----	2
4507-BF	WASHER, SPRING -----	2
4507-BG	NUT -----	2

FIG. 4508 STEERING POWER CYLINDER

4508

(P/S) (FOR MEIDEN P/S MOTOR)

(P/S) (FOR ND P/S MOTOR)

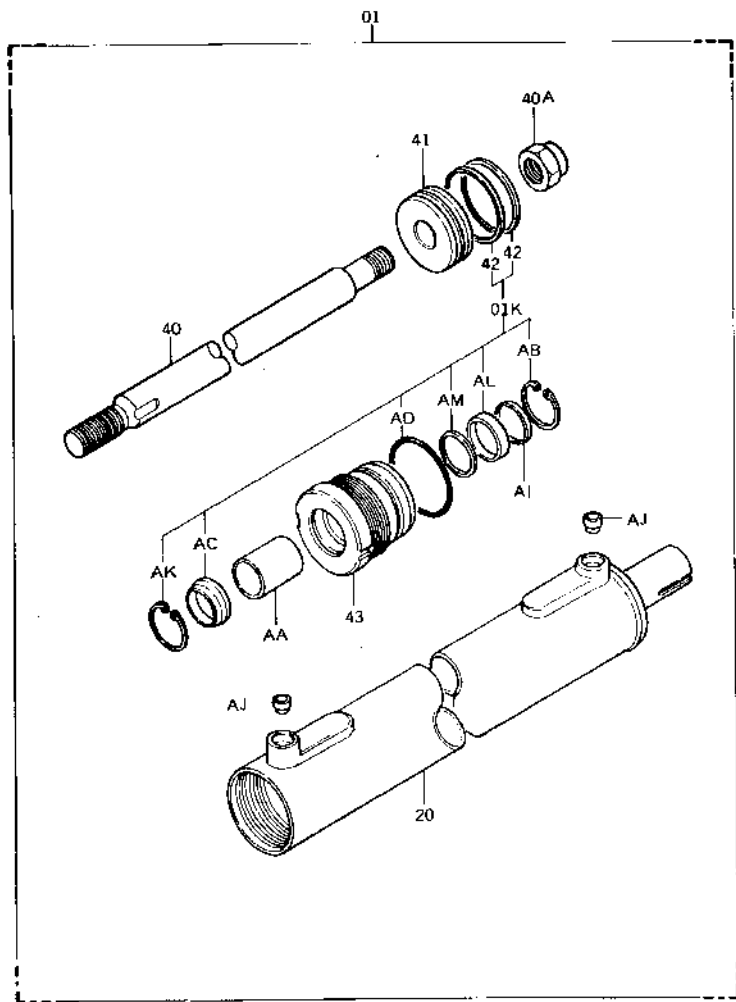

4508 007

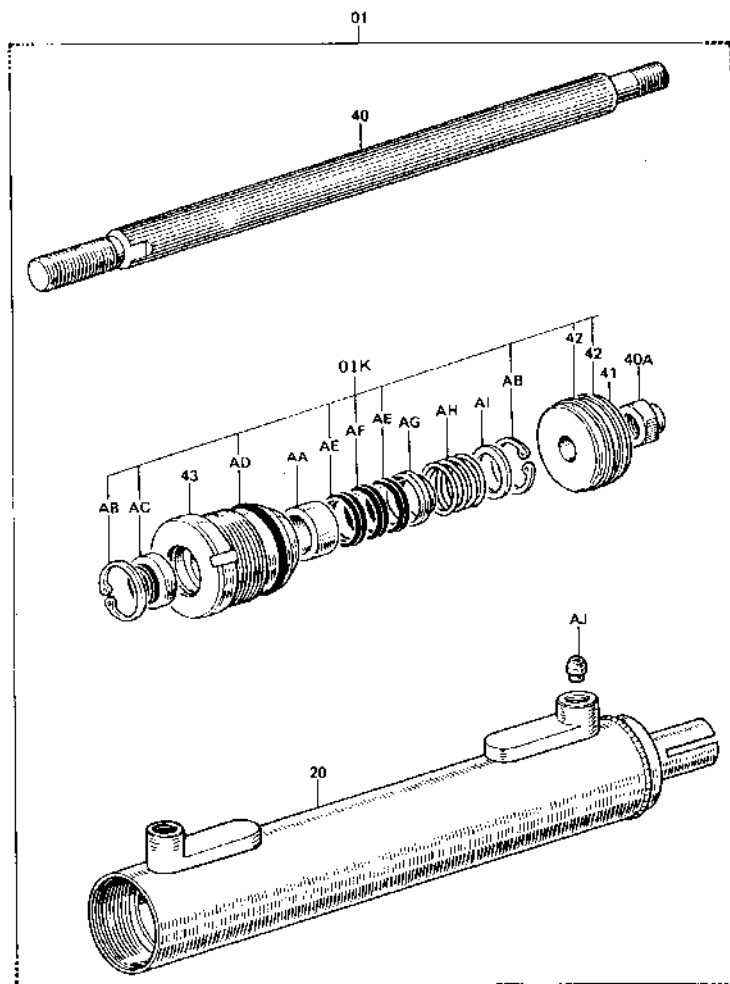

4508 005

**4508**

PART NAME CODE	PART NAME	QTY
4508-01	CYLINDER ASSY, POWER -----	1
4508-01K	PACKING KIT, POWER CYLINDER -----	1
4508-20	CYLINDER SUB-ASSY, POWER -----	1
4508-40	ROD, PISTON -----	1
4508-40A	NUT, SELF LGCK (FOR PISTON) -----	1
4508-41	PISTON -----	1
4508-42	RING, PISTON -----	2
4508-43	GUIDE, ROD -----	1
4508-AA	BUSHING -----	1
4508-AB	RING, SNAP -----	1- 2
4508-AC	SEAL, DUST -----	1
4508-AD	RING, O -----	1
4508-AE	PACKING, V -----	2
4508-AF	PACKING, V -----	1
4508-AG	ADAPTOR -----	1
4508-AH	SPRING, SEAL -----	1
4508-AI	COLLAR, REAR COVER -----	1
4508-AJ	SEAT -----	2
4508-AK	RING, SNAP -----	1
4508-AL	PACKING, U -----	1
4508-AM	RING, BACK UP -----	1



FIG. 4510 STEERING OIL PUMP

**4510**

(P/S)

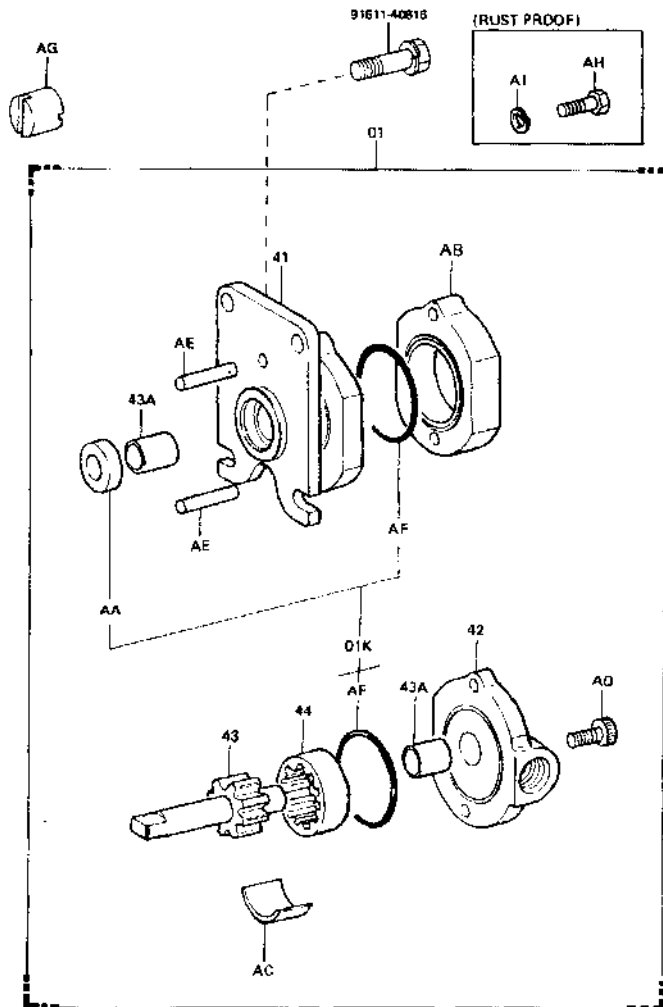

4510 003

PART NAME CODE	PART NAME	QTY
4510-01	PUMP ASSY, POWER STEERING -----	1
4510-01K	PUMP KIT, POWER STEERING -----	1
4510-41	FLANGE, MOUNTING -----	1
4510-42	COVER -----	1
4510-43	SHAFT, PINION -----	1
4510-43A	BUSH (FOR PINION SHAFT) -----	2
4510-44	GEAR, INTERNAL -----	1
4510-AA	SEAL, OIL -----	1
4510-AB	HOUSING, OIL PUMP -----	1
4510-AC	SEGMENT -----	1
4510-AD	BOLT -----	4
4510-AE	PIN -----	2
4510-AF	RING, O -----	2
4510-AG	JOINT, OLOHAM -----	1
4510-AH	BOLT -----	4
4510-AI	WASHER, SPRING -----	4

FIG. 4601 PARKING BRAKE

# 4601

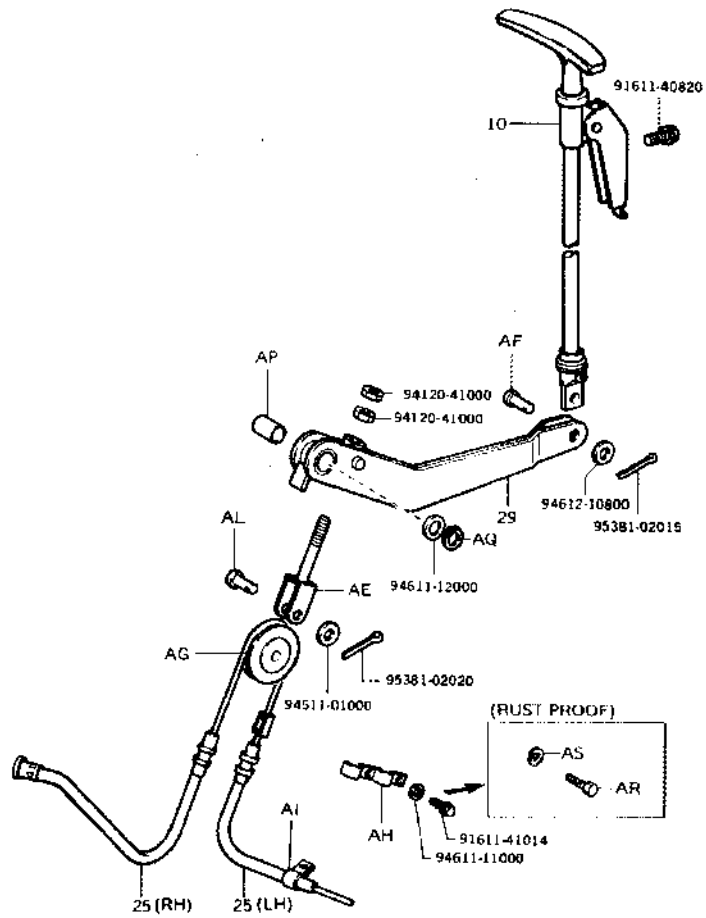

4601-000

PART NAME CODE	PART NAME	QTY
4601-10	HANDLE ASSY, PARKING BRAKE -----	1
4601-25	CABLE SUB-ASSY, PARKING BRAKE, NO.2 -----	1
4601-29	LEVER SUB-ASSY, INTERMEDIATE -----	1
4601-AE	BAR SUB-ASSY, EQUALIZER -----	1
4601-AF	PIN, W/HOLE -----	1
4601-AG	PULLEY -----	1
4601-AH	CLAMP, WIRE SET -----	1
4601-AI	CLAMP -----	1
4601-AL	PIN, W/HOLE -----	1
4601-AP	BUSHING -----	1
4601-AQ	RING, SNAP -----	1
4601-AR	BOLT -----	2
4601-AS	WASHER, SPRING -----	2

FIG. 4602 DEAD-MAN BRAKE

# 4602

(UL)

(UL)

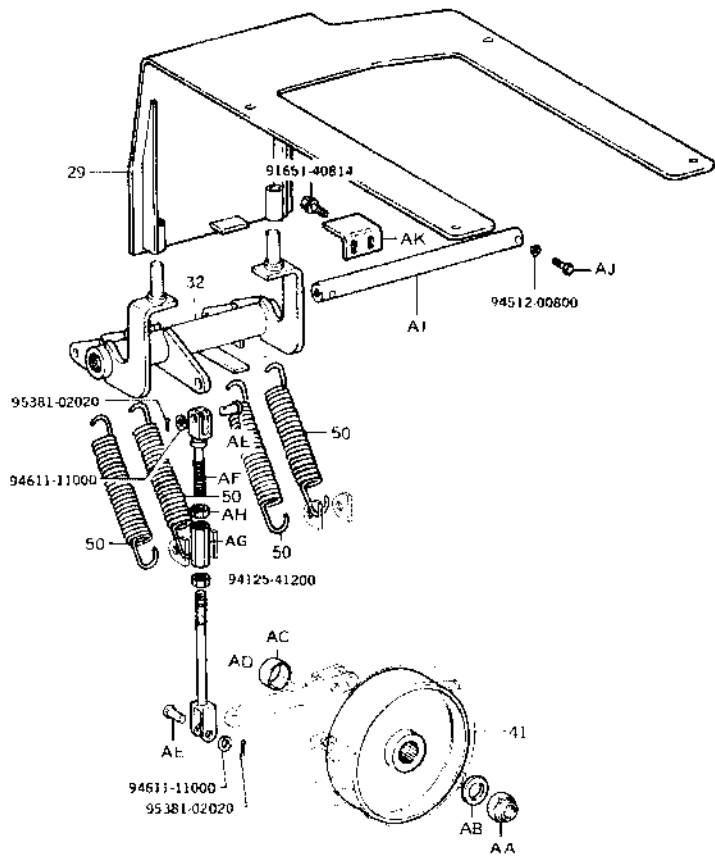

4602 002

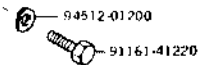
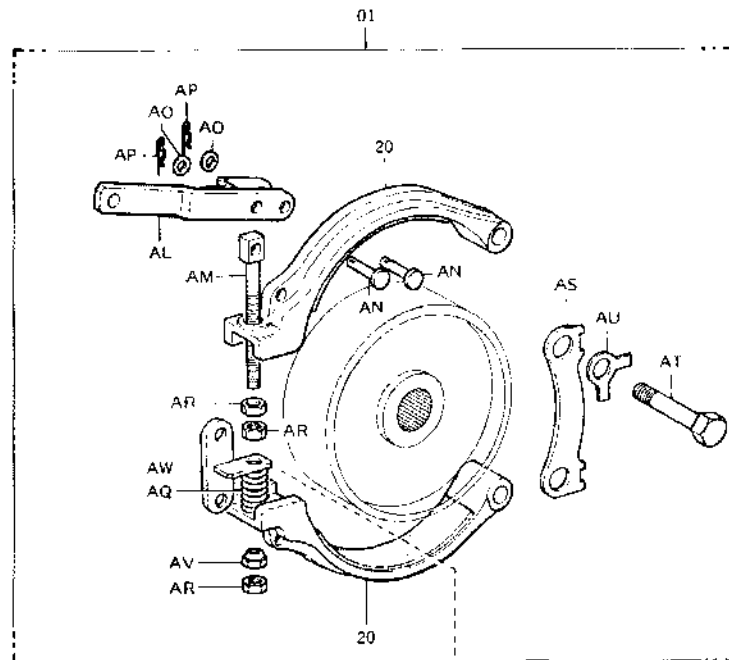

4602 001

# 4602

PART NAME CODE	PART NAME	QTY
4602-01	BRKFF ASSY, DEAD-MAN -----	1
4602-20	SHOE SUB-ASSY, BRAKE -----	2
4602-29	FRAME SUB-ASSY, SEAT -----	1
4602-32	LINK SUB-ASSY, DEAD-MAN BRAKE -----	1
4602-41	DRUM, DEAD-MAN BRAKE -----	1
4602-50	SPRING, BRAKE LINK -----	4
4602-AA	NUT, SELF LOCK -----	1
4602-AB	WASHER, PLATE -----	1
4602-AC	COLLAR -----	1
4602-AD	ROD SUB-ASSY, DEAD MAN BRAKE -----	1
4602-AE	PIN, W/HOLF -----	2
4602-AF	ROD SUB-ASSY, CONTROL VALVE -----	1
4602-AG	TURNBUCKLE -----	1
4602-AH	NUT -----	1
4602-AI	SHAFT -----	1
4602-AJ	BOLT -----	1
4602-AL	LEVER ASSY, BRAKE -----	1
4602-AM	STRUT -----	1
4602-AN	PIN, BRAKE LEVER -----	2
4602-AO	WASHER, PLATE -----	2
4602-AP	PIN, SNAP -----	2
4602-AQ	SPRING, SHOE RETURN -----	1
4602-AR	NUT -----	3
4602-AS	PLATE, GUIDE -----	1
4602-AT	STUD -----	2
4602-AU	WASHER, LOCK -----	2
4602-AV	NUT, STRUT -----	1
4602-AW	BRACKET -----	1

FIG. 4701 BRAKE PEDAL

# 4701

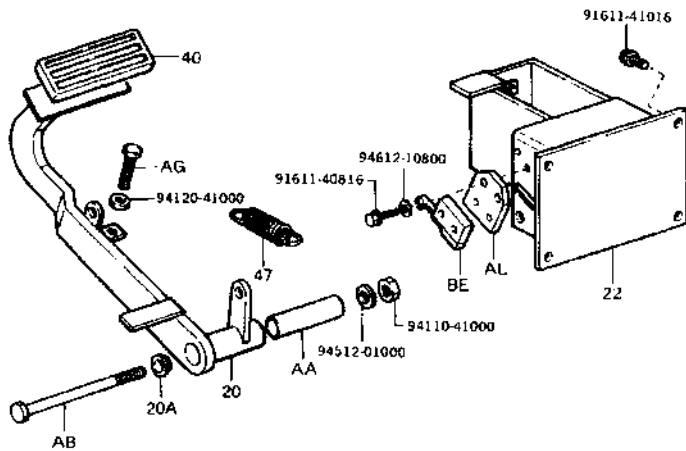
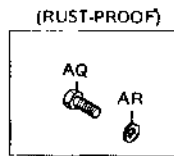
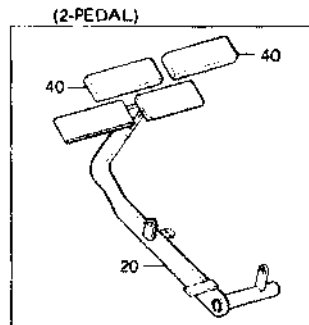

4701 015

PART NAME CODE	PART NAME	QTY
4701-20	PEDAL SUB-ASSY, BRAKE -----	1
4701-20A	BUSH (FOR BRAKE PEDAL) -----	2
4701-22	BRACKET SUB-ASSY, BRAKE PEDAL -----	1
4701-40	PAD, PEDAL -----	1
4701-47	SPRING, TENSION (FOR PEDAL RETURN) -----	1
4701-AA	SPACER -----	1
4701-AB	BOLT -----	1
4701-AG	BOLT, ADJUST -----	1
4701-AL	BRACKET, STOP SWITCH -----	1
4701-AQ	BOLT, STAINLESS -----	4
4701-AR	WASHER, SPRING -----	4
4701-BE	SWITCH ASSY, LIMIT -----	1

FIG. 4702 BRAKE MASTER CYLINDER

**4702**

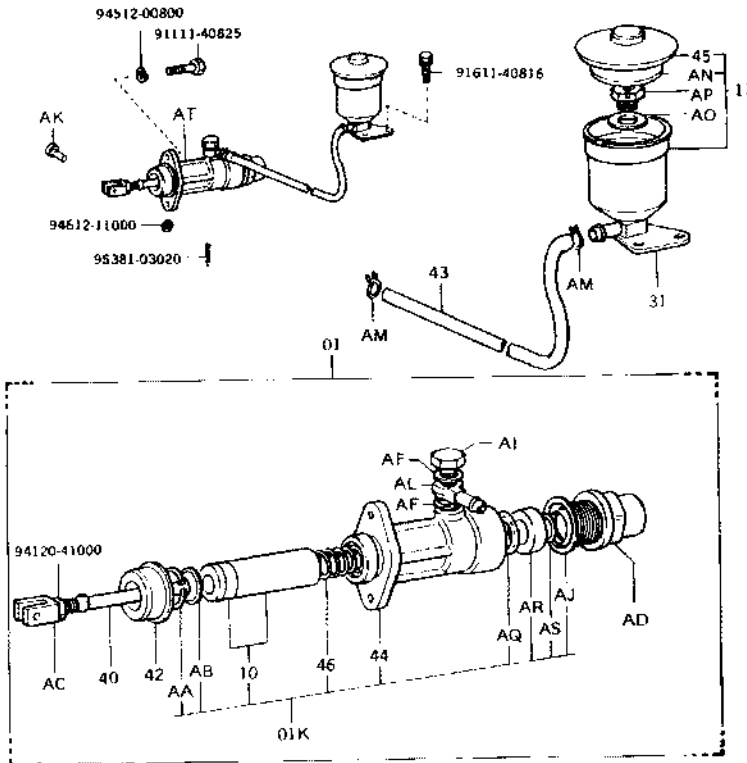

PART NAME CODE	PART NAME	QTY
4702-01	CYLINDER ASSY, MASTER	1
4702-01K	CYLINDER O/H KIT, MASTER	1
4702-10	PISTON SUB-ASSY, MASTER CYLINDER	1
4702-11	RESERVOIR SET, MASTER CYLINDER	1
4702-31	BRACKET SUB-ASSY, RESERVOIR	1
4702-40	RUD, PUSH	1
4702-42	BOOT	1
4702-43	HOSE, RESERVOIR	1
4702-44	BODY, MASTER CYLINDER	1
4702-45	CAP, RESERVOIR	1
4702-46	SPRING, COMPRESSION (FOR PISTON RETURN)	1
4702-AA	RING, HOLE SNAP	1
4702-AB	PLATE, PISTON STOP	1
4702-AC	CLEVIS, PUSH ROD	1
4702-AQ	CAP, BREATHER PLUG	1
4702-AF	GASKET	2
4702-AI	BOLT, UNION	1
4702-AJ	GASKET	1
4702-AK	PIN	1
4702-AL	UNION	1
4702-AM	CLAMP	2
4702-AN	FLDAT	1
4702-AO	WASHER	1
4702-AP	BOLT	1
4702-AQ	SPACER	1
4702-AR	CAP	1
4702-AS	SEAT	1
4702-AT	CYLINDER ASSY, MASTER W/RESERVOIR	1

FIG. 4714 BRAKE PIPE

**4714**

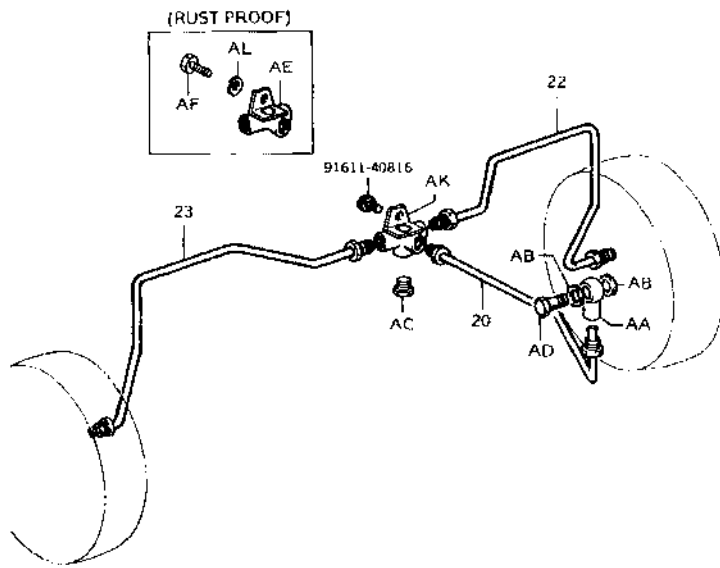

4714 008

PART NAME CODE	PART NAME	QTY
4714-20	PIPE SUB-ASSY, BRAKE, MAIN NO.1 -----	1
4714-22	PIPE SUB-ASSY, BRAKE, RH NO.1 -----	1
4714-23	PIPE SUB-ASSY, BRAKE, LH NO.1 -----	1
4714-AA	UNION -----	1
4714-AB	GASKET -----	2
4714-AC	PLUG -----	1
4714-AD	BDLT, UNION -----	1
4714-AE	3-WAY SUB-ASSY -----	1
4714-AF	BOLT -----	1
4714-AK	4-WAY SUB-ASSY, BRAKE -----	1
4714-AL	WASHER, SPRING -----	1

FIG. 4715 DRUM BRAKE

**4715**

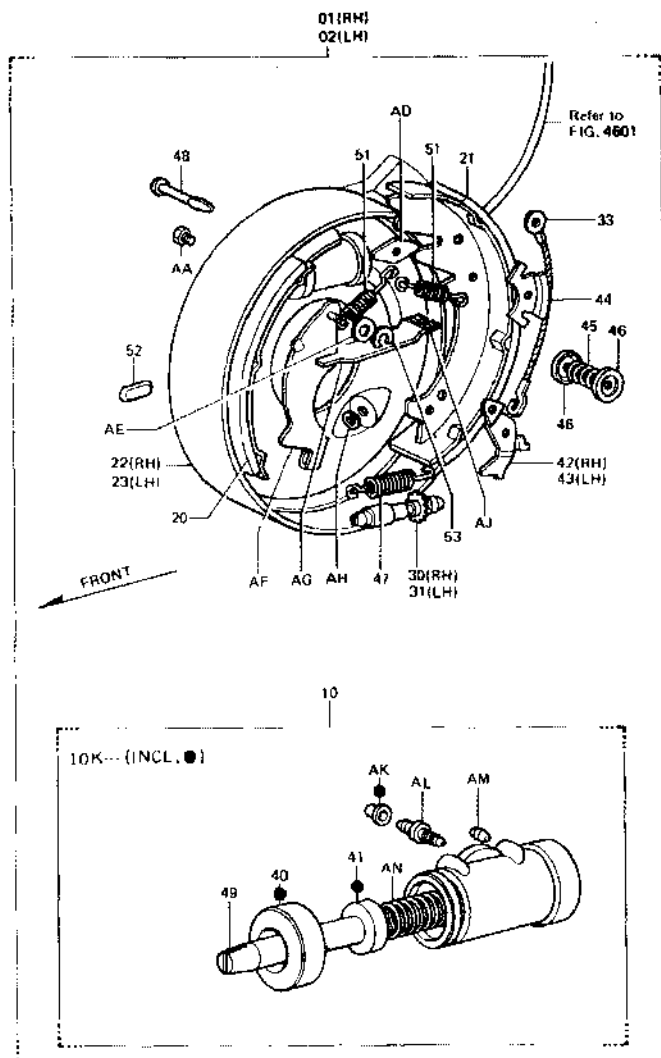

4715 001A

PART NAME CODE	PART NAME	QTY
4715-01	BRAKE ASSY, RH -----	1
4715-02	BRAKE ASSY, LH -----	1
4715-10	CYLINDER ASSY, WHEEL -----	2
4715-10K	CYLINDER Q/H KIT, WHEEL -----	2
4715-20	SHOE SUB-ASSY (FOR FRONT OR UPPER) -----	2
4715-21	SHOE SUB-ASSY (FOR REAR OR LOWER) -----	2
4715-22	PLATE SUB-ASSY, BACKING, RH -----	1
4715-23	PLATE SUB-ASSY, BACKING, LH -----	1
4715-30	SCREW SUB-ASSY, ADJUSTING, RH -----	1
4715-31	SCREW SUB-ASSY, ADJUSTING, LH -----	1
4715-33	CABLE & FITTING SUB-ASSY -----	2
4715-40	BOOT, WHEEL CYLINDER -----	4
4715-41	CUP, WHEEL CYLINDER PISTON -----	4
4715-42	LEVER, AUTOMATIC ADJUSTMENT, RH -----	1
4715-43	LEVER, AUTOMATIC ADJUSTMENT, LH -----	1
4715-44	GUIDE, CABLE -----	2
4715-45	SPRING, SHOE HOLD DOWN -----	4
4715-46	CUP, SHOE HOLD DOWN -----	8
4715-47	SPRING, ADJUSTER -----	2
4715-48	PIN, SHOE HOLD DOWN -----	4
4715-49	ROD, PUSH -----	4
4715-51	SPRING, ANCHOR TO SHOE -----	4
4715-52	COVER, ADJUSTING HOLE -----	2
4715-53	RING, PARKING LEVER RETAINING -----	2
4715-AA	BOLT & WASHER SET -----	4
4715-AD	PLATE, SHOE GUIDE -----	2
4715-AE	WASHER, SPRING -----	2
4715-AF	LEVER SUB-ASSY, PARKING -----	1
4715-AG	STRUT, LEVER -----	2
4715-AH	RING, SNAP -----	2
4715-AJ	SPRING, STRUT TO SHOE -----	2
4715-AK	CAP, BREATHER SCRLW -----	2
4715-AL	SCREW, BREATHER -----	2
4715-AM	SEAT, TUBE -----	2
4715-AN	SPRING, WHEEL CYLINDER -----	2



FIG. 5101 FRAME & WEIGHT

5101

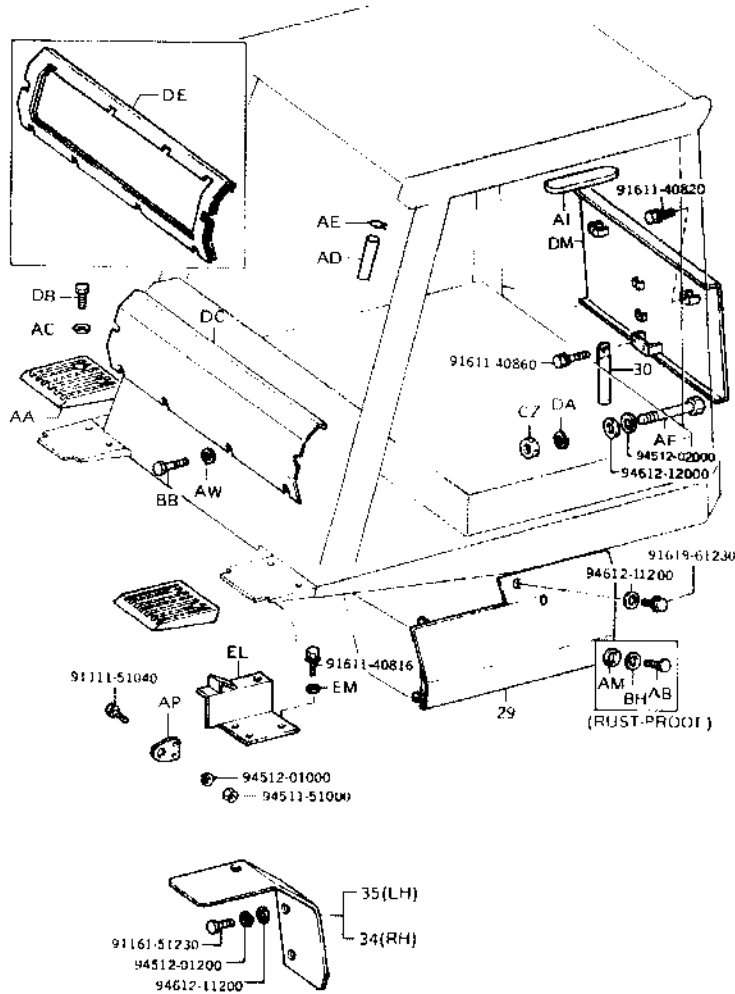

5101 016

PART NAME CODE	PART NAME	QTY
5101-29	COVER SUB-ASSY, BATTERY -----	1
5101-30	DRAW-BAR SUB-ASSY -----	1
5101-34	GUARD SUB-ASSY, MUD, RH -----	1
5101-35	GUARD SUB-ASSY, MUD, LH -----	1
5101-AA	GUARD, MUD, FRONT -----	2
5101-AB	BOLT -----	2
5101-AC	WASHER, WAVE -----	4
5101-AD	HOSE, LOW PRESSURE -----	2
5101-AE	CLAMP SUB-ASSY -----	2
5101-AF	BOLT, HEXAGON -----	2
5101-AI	SPONGE -----	1
5101-AM	WASHER, PLATE -----	2
5101-AP	PLATE, HANGER -----	2
5101-AW	WASHER, PLATE -----	10
5101-BB	BOLT -----	10
5101-BH	WASHER, SPRING -----	2
5101-CZ	NUT -----	2
5101-DA	WASHER -----	2
5101-DB	BOLT -----	4
5101-DC	PLATE, COVER -----	1
5101-DE	SEAL, COVER -----	1
5101-DM	COVER SUB-ASSY, REAR -----	1
5101-EL	PLATE SUB-ASSY, SIDE, LH -----	1
5101-EM	WASHER, PLATE -----	3

FIG. 5201 HOOD & HINGE

# 5201

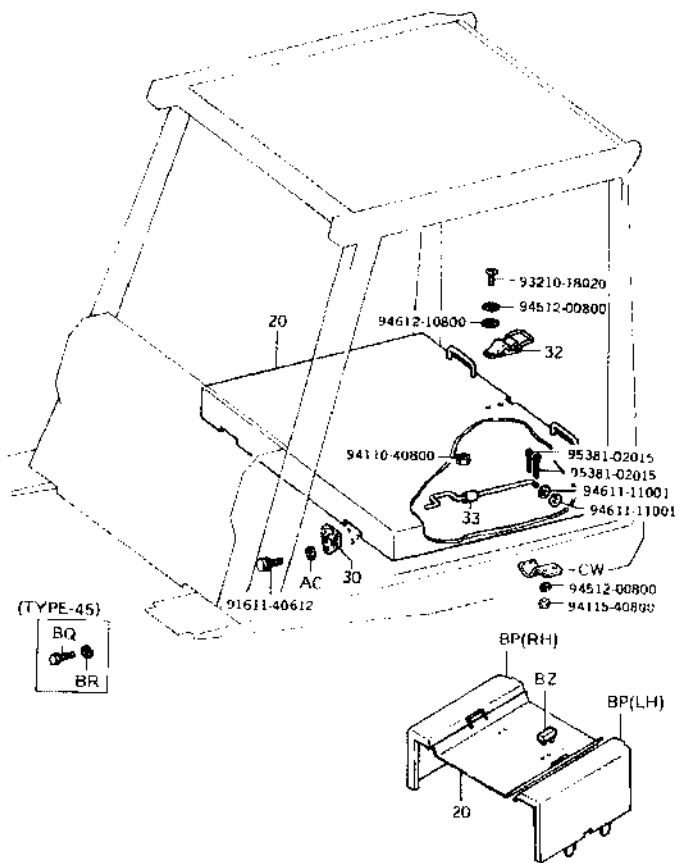

5201 013

PART NAME CODE	PART NAME	QTY
5201-20	HOOD SUB-ASSY, ENGINE (OR BATTERY) -----	1
5201-30	HINGE SUB-ASSY, ENGINE (OR BATTERY) HOOD ---	1
5201-32	CATCH SUB-ASSY (FOR HOOD) -----	1
5201-33	STAY SUB-ASSY, ENGINE (OR BATTERY) HOOD ----	1
5201-AC	WASHER, PLATE -----	6
5201-6P	HOOD SUB-ASSY, REAR -----	1
5201-BQ	BOLT -----	6
5201-BR	WASHER, SPRING -----	6
5201-BZ	CUSHION -----	2
5201-CW	SUPPORT, HOOD STAY -----	1

FIG. 5301 INSTRUMENT PANEL & FLOOR

**5301**

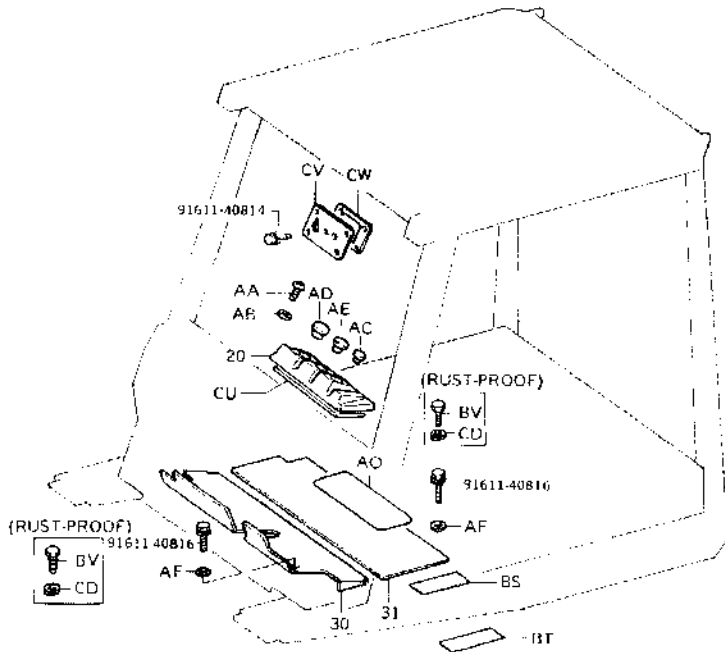

5301-020

PART NAME CODE	PART NAME	QTY
5301-20	PANEL SUB-ASSY, INSTRUMENT -----	1
5301-30	TDF-BOARD SUB-ASSY, NO.1 -----	1
5301-31	TDF-BOARD SUB-ASSY, NO.2 -----	1
5301-AA	SCREW -----	4
5301-AB	WASHER, WAVE -----	4
5301-AC	PLUG -----	1
5301-AD	PLUG -----	2
5301-AE	PLUG -----	1
5301-AF	WASHER, PLATE -----	4
5301-AO	SAFETY WALK -----	1
5301-BS	SAFETY WALK -----	1
5301-BT	SAFETY WALK -----	1
5301-BV	BOLT -----	4
5301-CD	WASHER, SPRING -----	4
5301-CU	RUBBER -----	1
5301-CV	PLATE -----	1
5301-CW	RUBBER -----	1

FIG. 5308 DRIVER SEAT

**5308**

(W/ABSORBER)

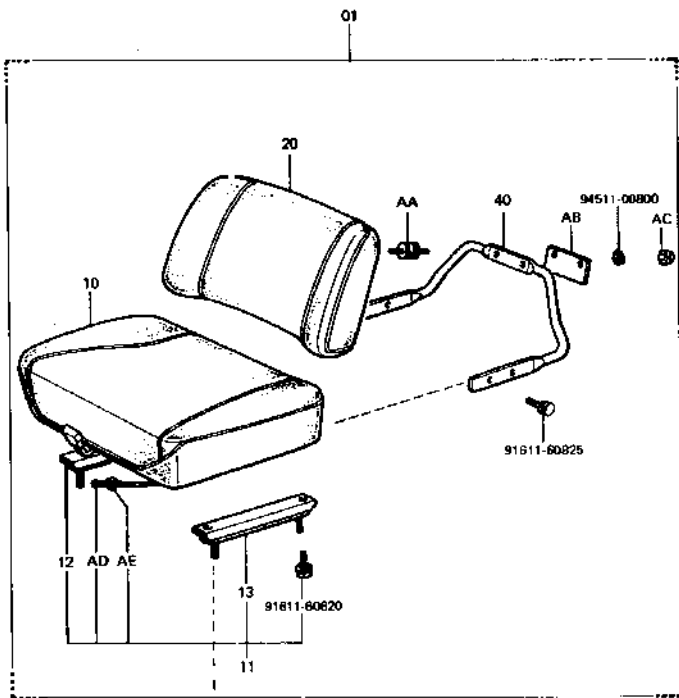

94512-00800  
94120-40900

5308-014

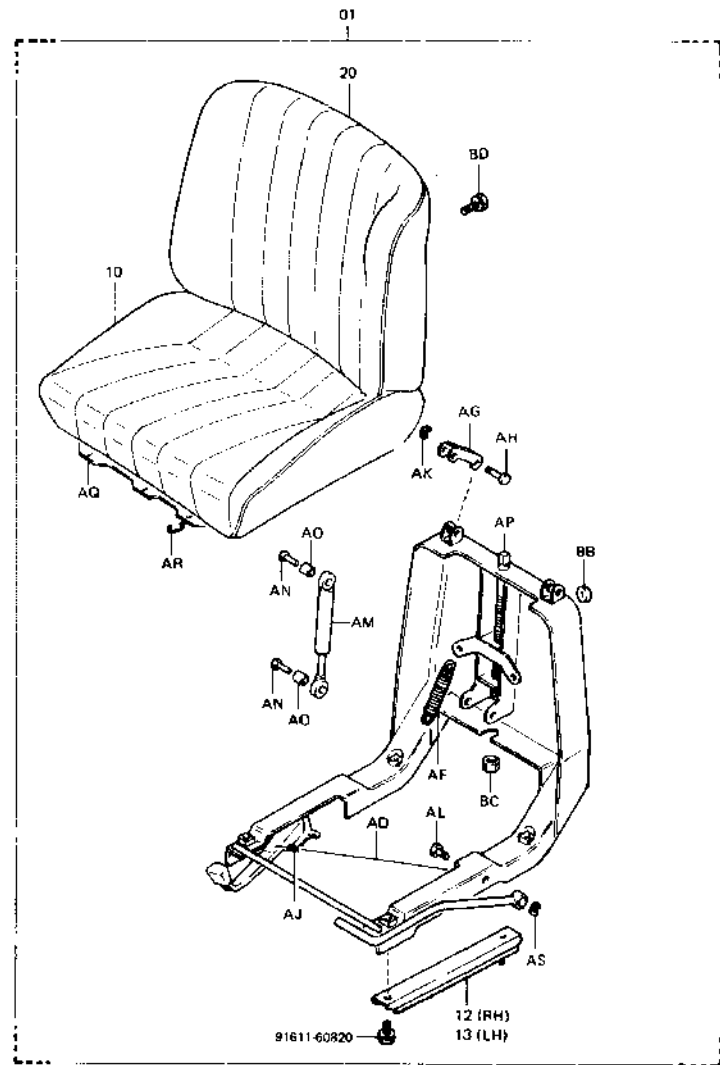

5308-008

**5308**

PART NAME CODE	PART NAME	QTY
5308-01	SEAT ASSY -----	1
5308-10	CUSHION ASSY -----	1
5308-11	TRACK ASSY -----	1
5308-12	TRACK ASSY, SEAT OUTER, RH -----	1
5308-13	TRACK ASSY, SEAT OUTER, LH -----	1
5308-20	SEAT SUB-ASSY, BACK -----	1
5308-40	FRAME, BACK SEAT -----	1
5308-AA	RUBBER, VIBRATION ISOLATOR -----	2
5308-AB	BRACKET, NUMBER PLATE -----	1
5308-AC	NUT, CAP -----	2
5308-AD	WIRE -----	1
5308-AE	WASHER -----	2
5308-AF	SPRING, TENSION, BACK SEAT -----	2
5308-AG	LINK -----	2
5308-AH	PIN -----	4
5308-AK	E-RING -----	4
5308-AL	PIN, NO.2 -----	2
5308-AM	SHOCK ABSORBER -----	1
5308-AP	ADJUSTER, ROD -----	1
5308-AQ	RUBBER, SEAT CUSHION -----	1
5308-AR	HOOK, SEAT CUSHION -----	10
5308-AS	RING, E -----	2
5308-BH	CUSHION -----	1
5308-BC	NUT, STOPPER -----	1
5308-BD	BOLT, W/WASHER -----	4

FIG. 5401 HEAD GUARD & ACCESSORY

**5401**

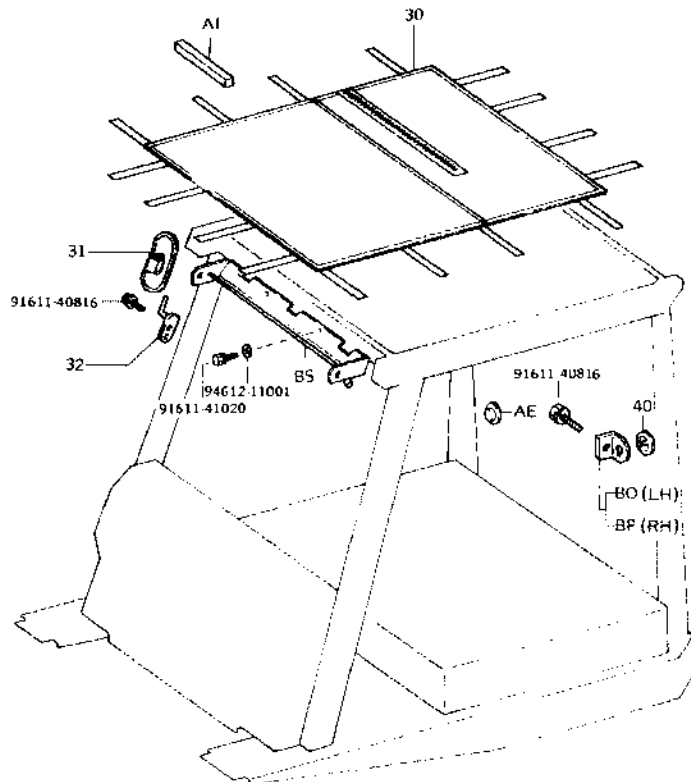

5401 017

PART NAME CODE	PART NAME	QTY
5401-30	SHEET SUB-ASSY, HEAD GUARD -----	1
5401-31	MIRROR SUB-ASSY, BACK -----	1
5401-32	BRACKET SUB-ASSY, BACK MIRROR -----	1
5401-40	REFLECTOR -----	2
5401-AE	PLUG, HOLE -----	1
5401-AI	CUSHION, SEET -----	2
5401-BO	BRACKET, REFLECTOR, LH -----	1
5401-BP	BRACKET, REFLECTOR, RH -----	1
5401-BS	PLATE SUB-ASSY, HEAU GUARD -----	1

FIG. 5405 INDICATOR PLATE

# 5405

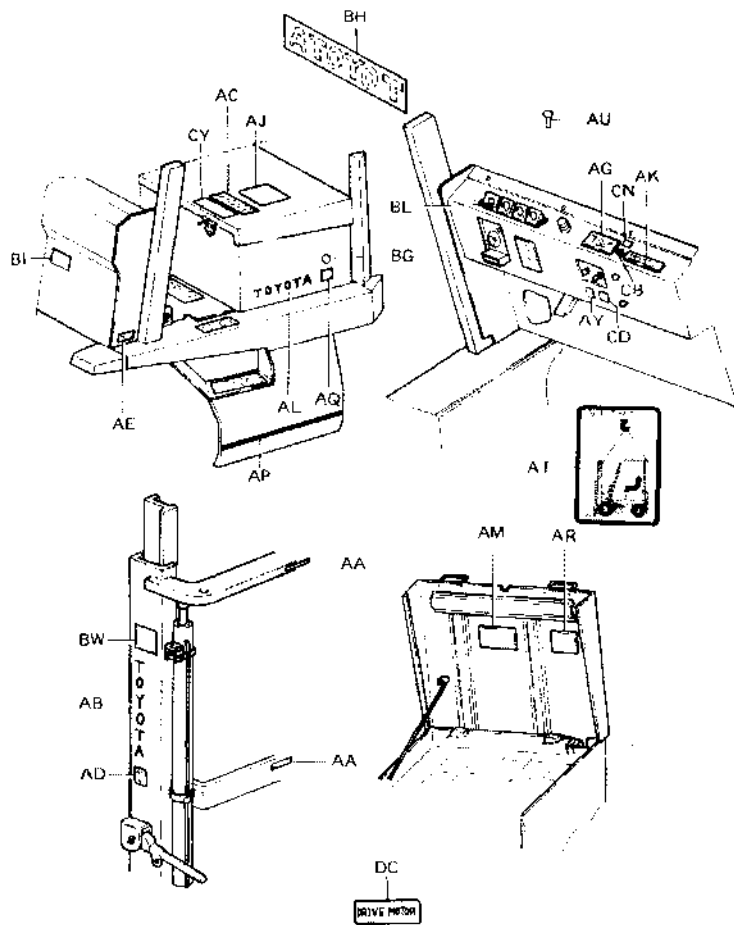

5405-020

PART NAME CODE	PART NAME	QTY
5405-AA	PLATE, CAUTION -----	2
5405-AC	PLATE, CAUTION -----	1
5405-AD	PLATE, CAUTION -----	2
5405-AE	PLATE, INDICATOR -----	1
5405-AG	PLATE, LOAD INDICATOR -----	1
5405-AJ	PLATE, CAUTION -----	1
5405-AK	PLATE, INDICATOR -----	1
5405-AL	TOYOTA MARK -----	2
5405-AM	PLATE, SERVICE INDICATOR -----	1
5405-AP	STRIPE -----	2
5405-AQ	PLATE, CAPACITY INDICATOR -----	2
5405-AR	PLATE, CAUTION -----	1
5405-AT	PLATE, CAUTION -----	1
5405-AU	RIVET -----	4
5405-AY	PLATE, CAUTION -----	1
5405-BG	PLATE, TEMPERATURE -----	2
5405-BH	MARK, TOYOTA -----	1
5405-BI	PLATE, VOLTAGE -----	1
5405-BL	PLATE, DISCHARGE INDICATOR -----	1
5405-BW	MARK, SYMBOL -----	2
5405-CB	PLATE, INDICATOR -----	1
5405-CD	PLATE, CAUTION -----	1
5405-CN	PLATE, INDICATOR -----	1
5405-CY	PLATE, CAUTION -----	1
5405-DC	PLATE, OLA INDICATOR -----	1

FIG. 5502 CANVAS CABIN & FRONT GLASS

**5502**

(FRONT GLASS)

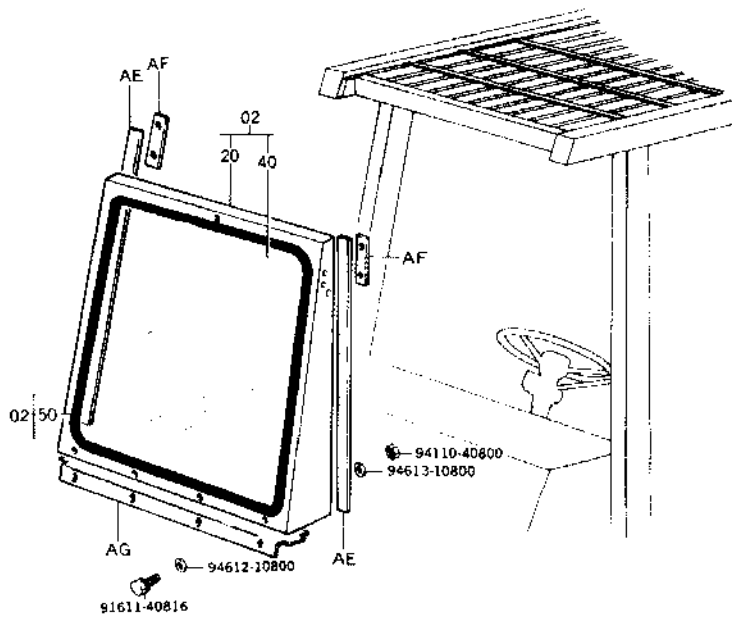

PART NAME: CODE	PART NAME	QTY
5502-02	PANEL ASSY, FRONT GLASS -----	1
5502-20	PANEL SUB-ASSY, FRONT GLASS -----	1
5502-40	GLASS, WINDSHIELD -----	1
5502-50	WEATHER STRIP -----	1
5502-AE	CUSHION, WINDSHIELD -----	2
5502-AF	PLATE, WINDSHIELD -----	2
5502-AG	PLATE, FRONT -----	1

5502 005

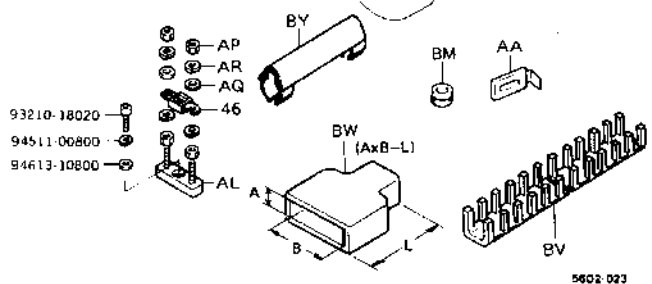
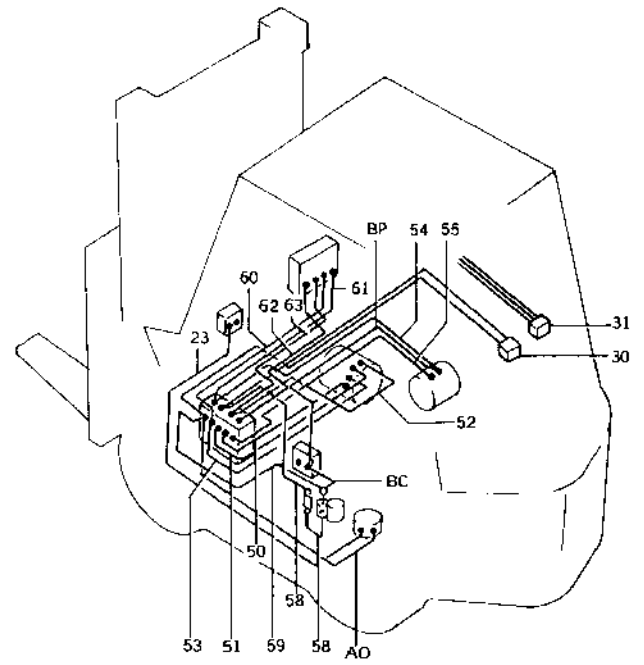
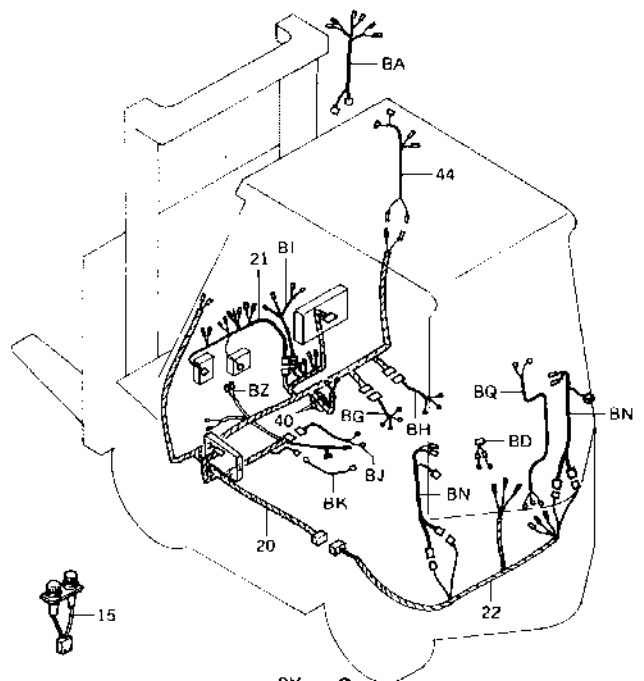

FIG. 5602 WIRING & CLAMP

# 5602

HSP, STM

HSP, STM



23	P22 ~ AC	60	P6 ~ P6
50	P3 ~ F	61	N1 ~ N1
51	P4 ~ E	62	P2 ~ P2
52	P5 ~ A	63	P5 ~ P5
53	P8 ~ B	BC	N0 ~ N1
54	N1 ~ FD	BP	ND ~ FD
55	P12 ~ AC		
58	P1 ~ B1		
	P21 ~ P21		
59	N1 ~ N1		

60	P6 ~ P6
61	N1 ~ N1
62	P2 ~ P2
63	P5 ~ P5
BC	N0 ~ N1
BP	ND ~ FD

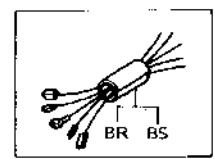
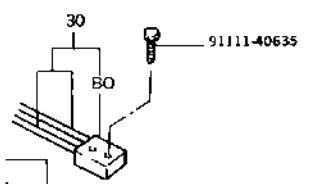

5602 024

FIG. 5602 WIRING & CLAMP

# 5602

DPR

DPR

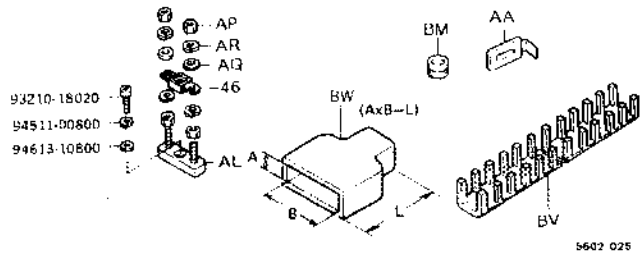
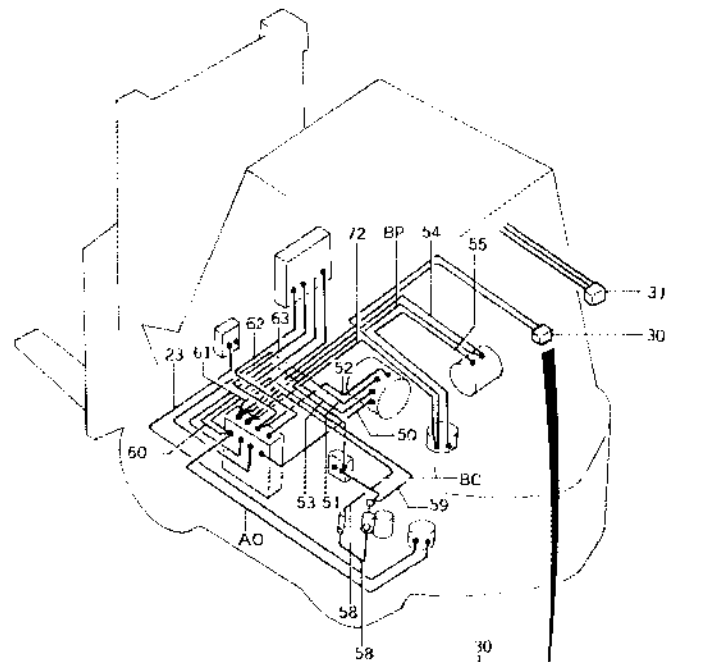
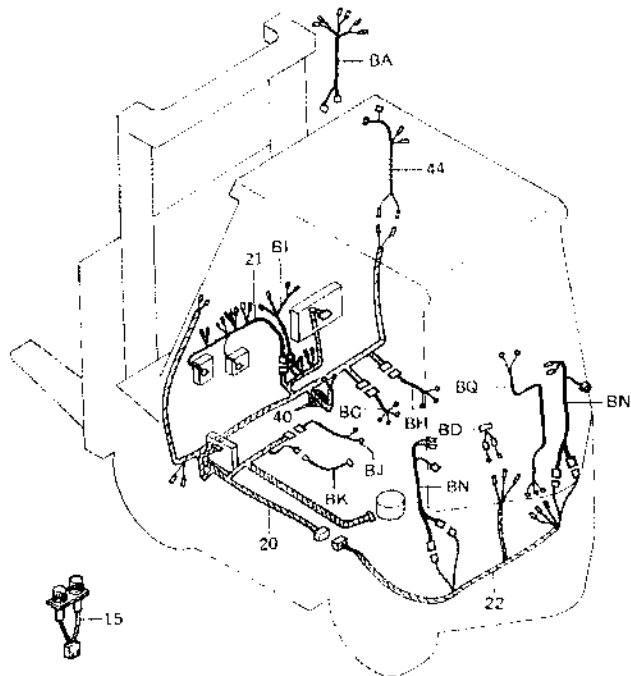

23	P22 ~ AC
50	P3 ~ F
51	P4 ~ E
52	P5 ~ A
53	P6 ~ B
54	N1 ~ FD
55	P12 ~ AC
58	P1 ~ P1
59	P21 ~ P21
59	N1 ~ N1

60	P6 ~ P6
61	N1 ~ N1
62	P2 ~ P2
63	P5 ~ P5
AO	N1 ~ BD
BC	N0 ~ N1
BP	N0 ~ FD
72	P1 ~ P1

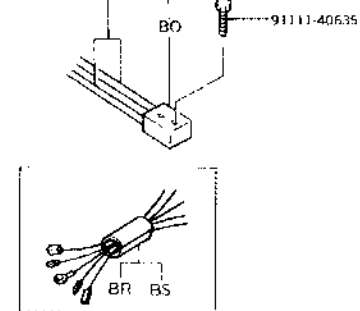

5602 026

# 5602

PART NAME CODE	PART NAME	QTY
5602-15	FUSE ASSY -----	1
5602-20	HARNESS SUB-ASSY, WIRING -----	1
5602-21	HARNESS SUB-ASSY, PANEL -----	1
5602-22	HARNESS SUB-ASSY, RR -----	1
5602-23	WIRING SUB-ASSY, POWER STEERING -----	1
5602-30	CONNECTOR SUB-ASSY -----	1
5602-31	CONNECTOR SUB-ASSY, BATTERY -----	1
5602-40	FUSE -----	2
5602-44	CORD, HEAD LAMP -----	1- 2
5602-46	FUSE -----	1
5602-50	WIRING, DRIVE MOTOR, NO.1 -----	1
5602-51	WIRING, DRIVE MOTOR, NO.2 -----	1
5602-52	WIRING, DRIVE MOTOR, NO.3 -----	1
5602-53	WIRING, DRIVE MOTOR, NO.4 -----	1
5602-54	WIRING, PUMP MOTOR, NO.1 -----	1
5602-55	WIRING, PUMP MOTOR, NO.2 -----	1
5602-58	WIRING, POWER STEERING, NO.1 -----	1
5602-59	WIRING, POWER STEERING, NO.2 -----	1
5602-60	WIRING, CONTROLLER, NO.1 -----	1
5602-61	WIRING, CONTROLLER, NO.2 -----	1
5602-62	WIRING, CONTROLLER, NO.3 -----	1
5602-63	WIRING, CONTROLLER, NO.3 -----	1
5602-72	WIRING, CONTACTOR -----	1
5602-AA	CLAMP -----	6
5602-A0	HARNESS, POWER STEERING -----	1
5602-BA	HARNESS ASSY -----	2
5602-BB	HARNESS, LIMI SWITCH -----	1
5602-BC	WIRING SUB-ASSY, BREAKER -----	1
5602-BD	HARNESS, DIODE, ROTARY LAMP -----	1
5602-BG	HARNESS, PUMP SWITCH -----	1
5602-BH	HARNESS, SIDE BRAKE SWITCH -----	1
5602-BI	HARNESS ASSY, DIRECTION -----	1
5602-BJ	HARNESS, STOP LAMP SWITCH -----	1
5602-BK	HARNESS, BRAKE SWITCH -----	1
5602-BM	GROMMET -----	4
5602-BN	HARNESS ASSY, REAR COMBINATION -----	2
5602-B0	PLUG -----	1
5602-BP	WIRING SUB-ASSY, PUMP MOTOR -----	1
5602-BQ	HARNESS, ROTARY LAMP -----	1
5602-BS	RUBBER, CABLE NO.2 -----	1
5602-BV	BUSH -----	2
5602-BW	BOOT -----	99
5602-BY	COVER SUB-ASSY, HARNESS -----	1
5602-BZ	HARNESS SUB-ASSY, OLA -----	1

FIG. 5611 LAMP

**5611**

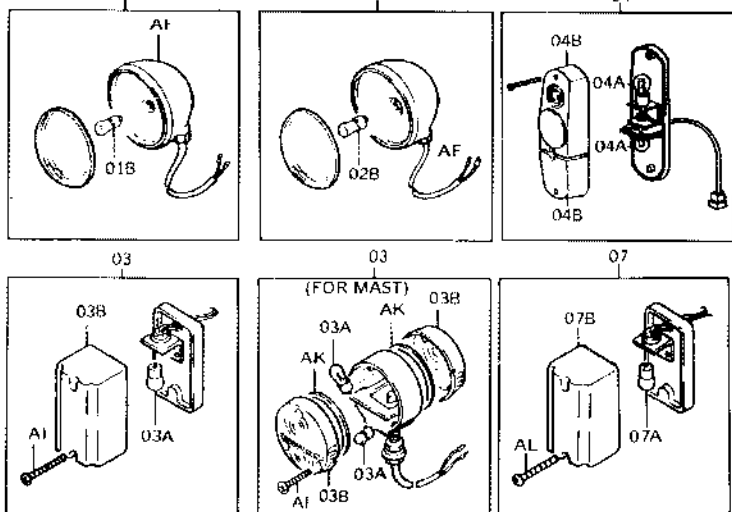
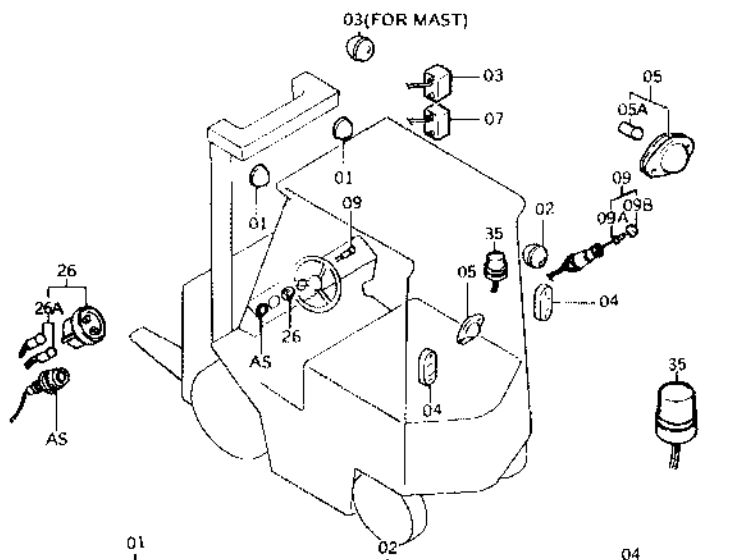

5611-013

PART NAME CODE	PART NAME	QTY
5611-01	LAMP ASSY, HEAD -----	2
5611-01B	BULB (FOR HEAD LAMP) -----	2
5611-02	LAMP ASSY, WORKING -----	1
5611-02B	BULB (FOR WORKING LAMP) -----	1
5611-03	LAMP ASSY, FLASHER -----	2
5611-03A	BULB (FOR FLASHER LAMP) -----	2
5611-03B	LENS (FOR FLASHER LAMP) -----	2
5611-04	LAMP ASSY, REAR COMBINATION -----	2
5611-04A	BULB (FOR REAR COMBINATION LAMP) -----	2
5611-04B	LENS (FOR REAR COMBINATION LAMP) -----	2
5611-05	LAMP ASSY, LICENCE -----	1
5611-05A	BULB (FOR LICENCE LAMP) -----	1
5611-07	LAMP ASSY, CLEARANCE -----	2
5611-07A	BULB (FOR CLEARANCE LAMP) -----	2
5611-07B	LENS (FOR CLEARANCE LAMP) -----	2
5611-09	LAMP ASSY, PILOT -----	1
5611-09A	BULB (FOR PILOT LAMP) -----	1
5611-09B	LENS (FOR PILOT LAMP) -----	1
5611-26	LAMP ASSY, COMBINATION PILOT -----	1
5611-26A	BULB (FOR COMBINATION PILOT LAMP) -----	2
5611-35	LAMP ASSY, LOTARY -----	1
5611-AF	CORD, HEAD LAMP -----	3
5611-AI	SCREW -----	4
5611-AK	PACKING -----	4
5611-AL	SCREW -----	4
5611-AS	LAMP ASSY, PILOT -----	1

FIG. 5612 LAMP BRACKET

**5612**

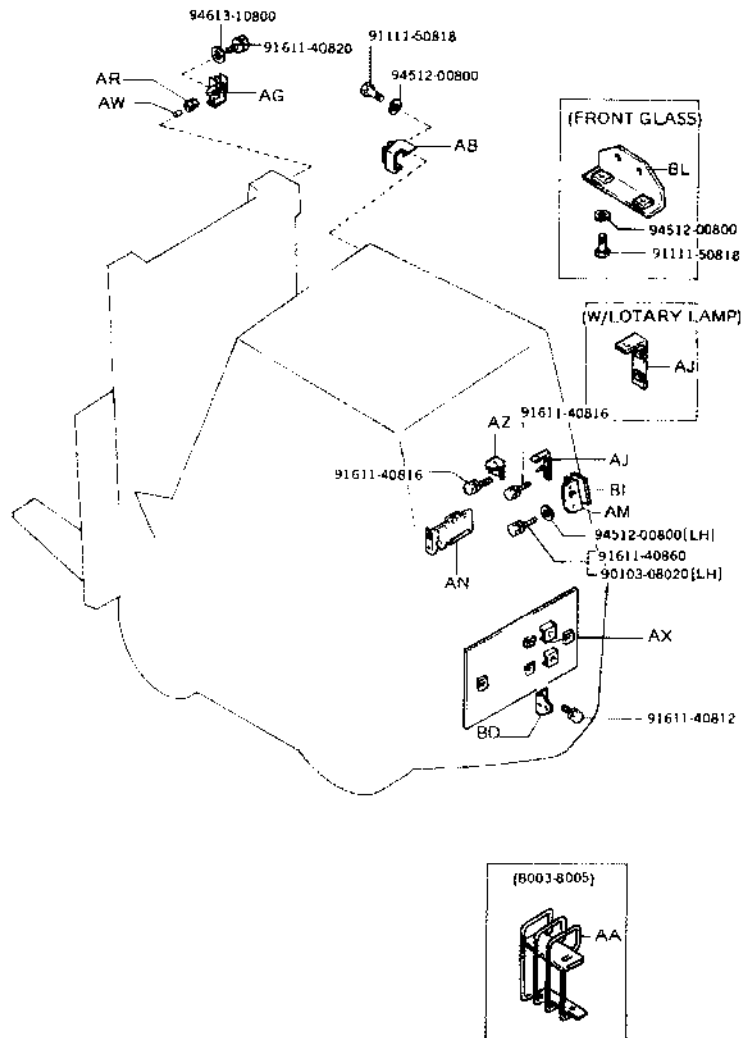

PART NAME CODE	PART NAME	QTY
5612-AB	BRACKET SUB-ASSY, HEAD LAMP -----	1
5612-AC	BRACKET, FLASHER LAMP -----	1
5612-AJ	BRACKET, WORKING LAMP -----	1
5612-AM	BRACKET, REAR COMBINATION LAMP -----	1
5612-AN	PLATE SUB-ASSY, LICENCE -----	1
5612-AR	WASHER, RUBBER -----	4
5612-AW	COLLER -----	4
5612-AX	PLATE SUB-ASSY, REAR OPTION -----	1
5612-AZ	BRACKET SUB-ASSY, ROTARY LAMP -----	1
5612-BU	BRACKET SUB-ASSY, BACK BUZZER -----	1
5612-BI	PLATE, GUM -----	2
5612-BL	PLATE SUB-ASSY, HEAD LAMP -----	1

5612-013

FIG. 5702 METER & SWITCH

5702

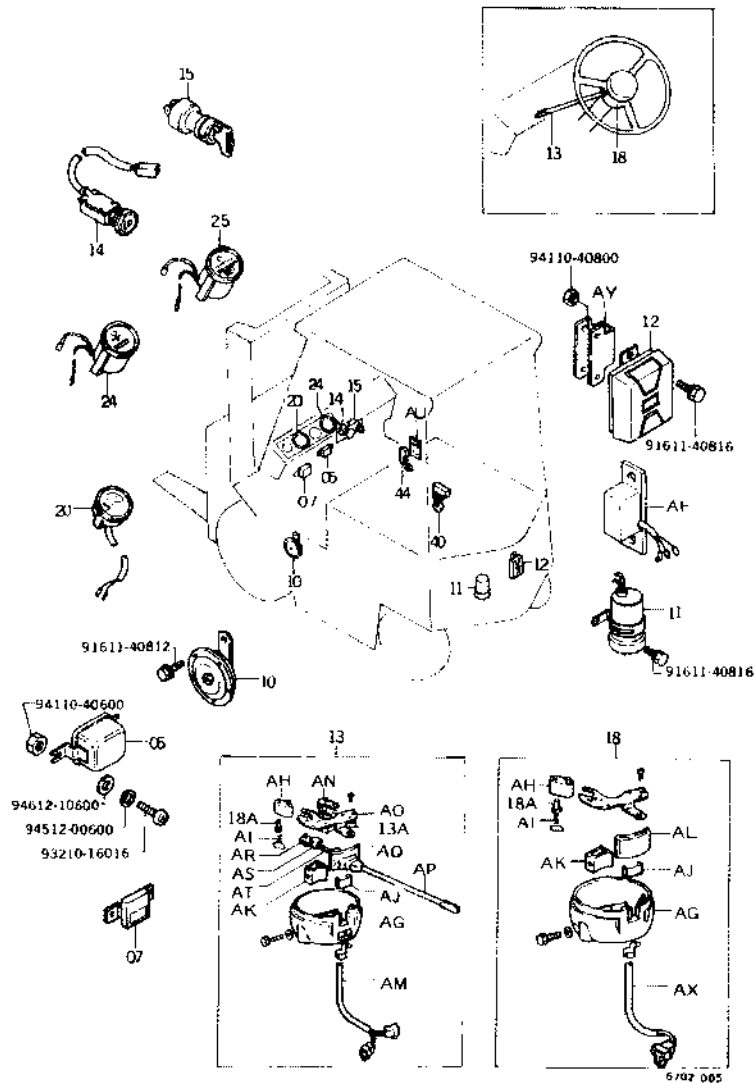

PART NAME CODE	PART NAME	QTY
5702-05	RELAY ASSY, FLASHER -----	1
5702-07	BOX ASSY, OVER DISCHARGE -----	1
5702-10	HORN ASSY -----	1
5702-11	BUZZER ASSY, BACK -----	1
5702-12	CHIME ASSY, BACK -----	1
5702-13	SWITCH ASSY, TURN SIGNAL -----	1
5702-13A	SWITCH SUB-ASSY, MICRO -----	2
5702-14	SWITCH ASSY, LIGHT CONTROL -----	1
5702-15	SWITCH ASSY, STARTER -----	1
5702-18	SWITCH ASSY, HORN -----	1
5702-18A	CONTACT, HORN -----	1
5702-20	METER ASSY, VOLTAGE -----	1
5702-24	METER ASSY, HOUR -----	1
5702-25	INDCATOR ASSY, BATTERY CAPACITY -----	1
5702-40	SWITCH ASSY, LIMIT (FOR PUMP MOTDR) -----	2
5702-44	SWITCH ASSY, LIMIT, (FOR PARKING BRAKE) -----	1
5702-AF	RELAY ASSY, BATTERY CAPACITY -----	1
5702-AG	BODY, SWITCH -----	1
5702-AH	HOLDER, HORN POINT -----	1
5702-AI	SPRING, HORN CONTACT -----	1
5702-AJ	COVER -----	1
5702-AK	LOCKING BLOCK -----	1
5702-AL	COVER, RUBBER -----	1
5702-AM	HARNESS ASSY -----	1
5702-AN	ACTUATOR -----	2
5702-AO	PLATE, SWITCH -----	1
5702-AP	LEVER SIGNAL -----	1
5702-AQ	BELLOWS -----	1
5702-AR	ROLLER -----	1
5702-AS	HOLDER, ROLLER -----	1
5702-AT	SPRING -----	1
5702-AU	BRACKET, PARKING BRAKE -----	1
5702-AX	HARNESS ASSY -----	1
5702-AY	BRACKET, CHIME -----	1

FIG. 5706 SPEEDOMETER & SPEED ALARM

**5706**

(SPEEDMETER)

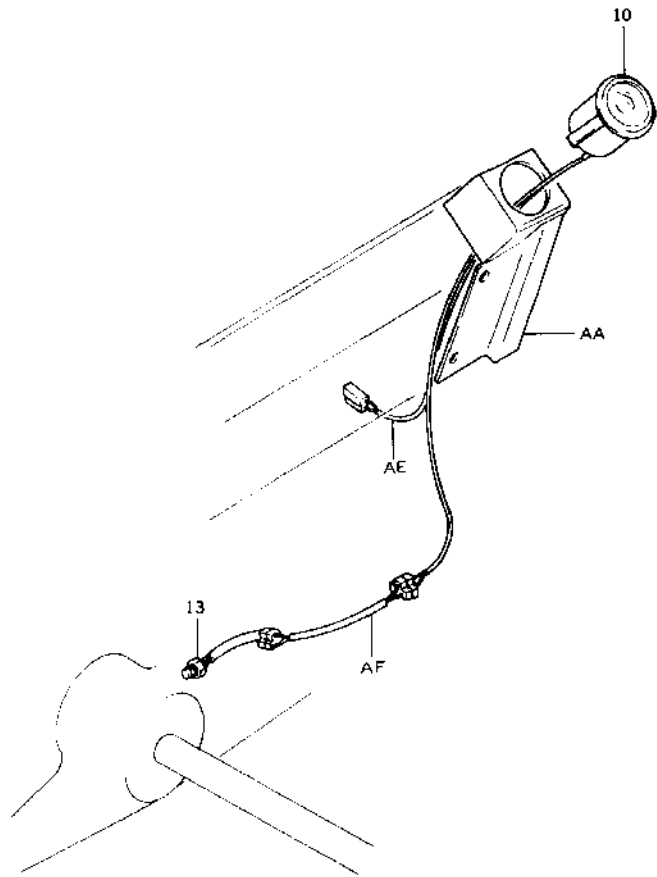

5706 005

(SPEED ALARM)

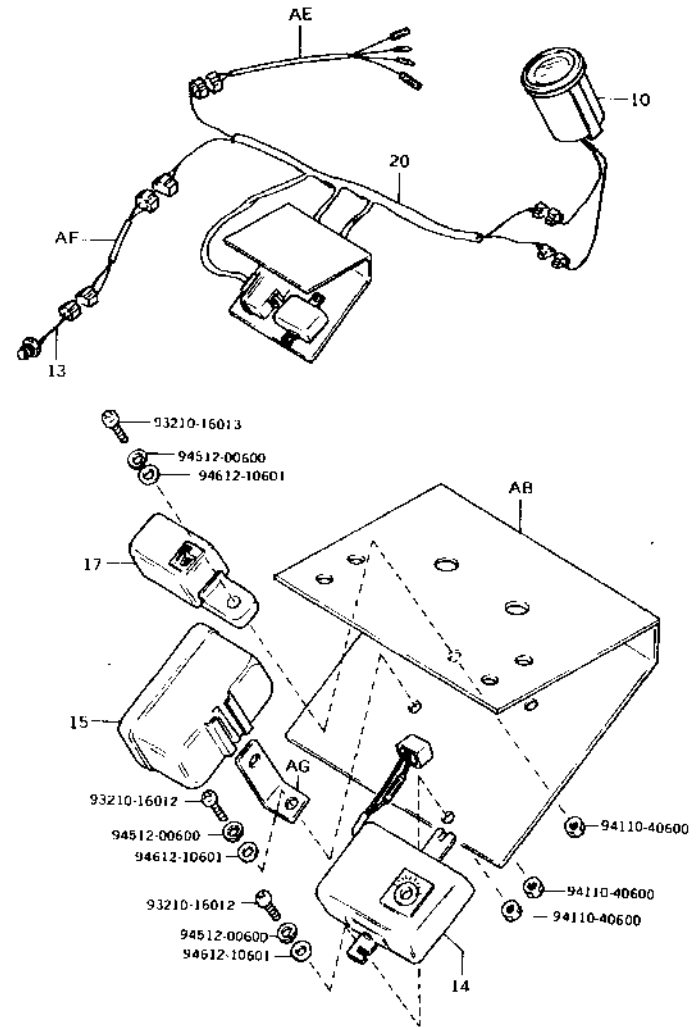

5706 006

**5706**

PART NAME CODE	PART NAME	QTY
5706-10	SPEEDOMETER ASSY -----	1
5706-13	PICK-UP ASSY, SPEEDOMETER -----	1
5706-14	BOX ASSY, SPEED ALARM -----	1
5706-15	RELAY ASSY -----	1
5706-17	BUZZER ASSY, SPEED ALARM -----	1
5706-20	HARNESS SUB-ASSY, SPEED ALARM -----	1
57D6-AA	BRACKET, SPEEDOMETER -----	1
57D6-AB	BRACKET SUB-ASSY, SPEED ALARM -----	1
57D6-AE	HARNESS, SPEEDOMETER -----	1
57D6-AF	HARNESS, SPEEDOMETER PICK UP -----	1
5706-AG	STAY, RELAY -----	1



FIG. 5801 WIPER MOTOR & BLADE

**5801**

(FRONT GLASS)

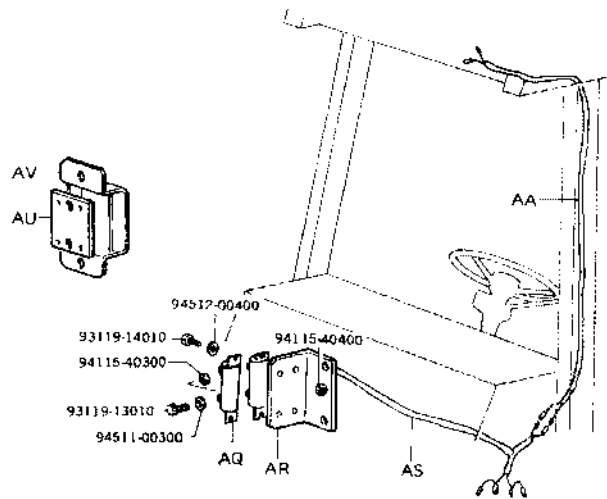
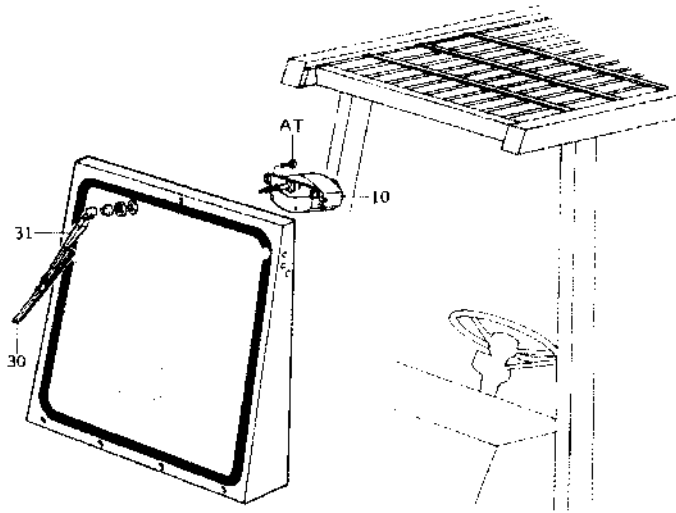

5801 006

PART NAME CODE	PART NAME	QTY
5801-10	MOTOR ASSY, WIPER -----	1
5801-30	BLADE SUB-ASSY, WIPER -----	1
5801-31	ARM SUB-ASSY, WIPER -----	1
5801-AA	HARNES, WIPER -----	1
5801-AQ	RESISTER ASSY -----	2
5801-AS	HARNES ASSY, RESISTER -----	1
5801-AT	SCREW, W/WASHER -----	2
5801-AU	PLATE, RESISTOR SET -----	1
5801-AV	COVER, RESISTOR -----	1

FIG. 6101 MAST

**6101**

F

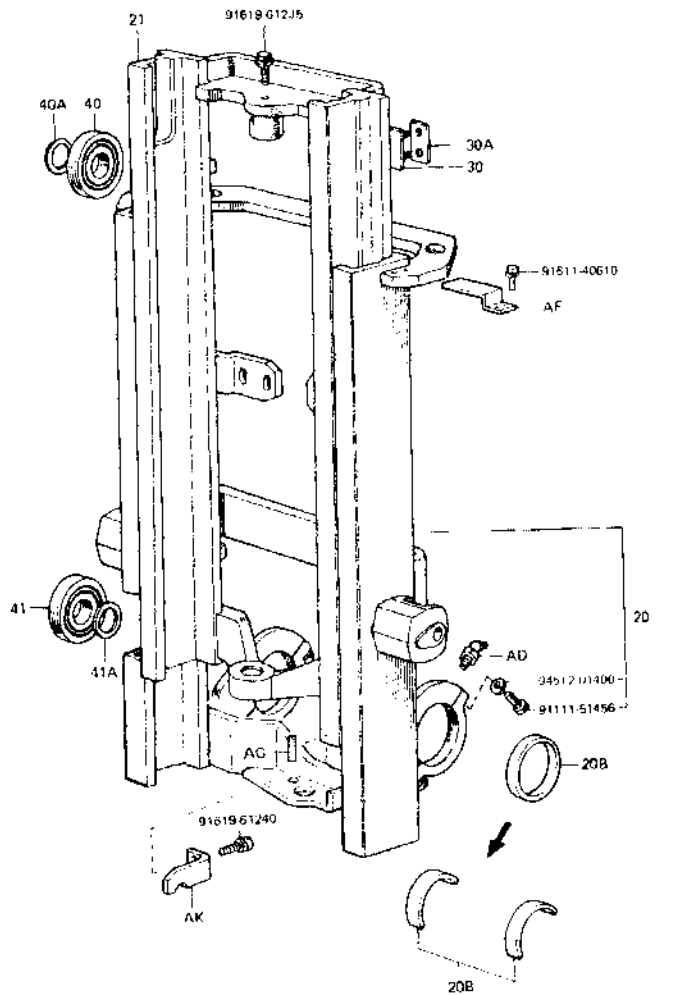

6101-066

PART NAME CODE	PART NAME	QTY
6101-20	MAST SUB-ASSY, OUTER -----	1
6101-20B	BUSH, MAST SUPPORT -----	1
6101-21	MAST SUB-ASSY, INNER -----	1
6101-30	STRIP SUB-ASSY, OUTER MAST -----	2
6101-30A	SHIM, OUTER MAST STRIP -----	99
6101-40	ROLLER, LIFT (FOR OUTER MAST) -----	2
6101-40A	SHIM, LIFT ROLLER (FOR OUTER MAST) -----	99
6101-41	ROLLER, LIFT (FOR INNER MAST) -----	2
6101-41A	SHIM, LIFT ROLLER (FOR INNER MAST) -----	99
6101-AD	FITTING, GREASE -----	2
6101-AF	COVER, ROLLER -----	2
6101-AG	PIN, SPRING -----	1
6101-AK	STOPPER, REAR CYLINDER -----	1

( F ) ( 1 )

C208

FIG. 6301 LIFT BRACKET & FORK

6301

F

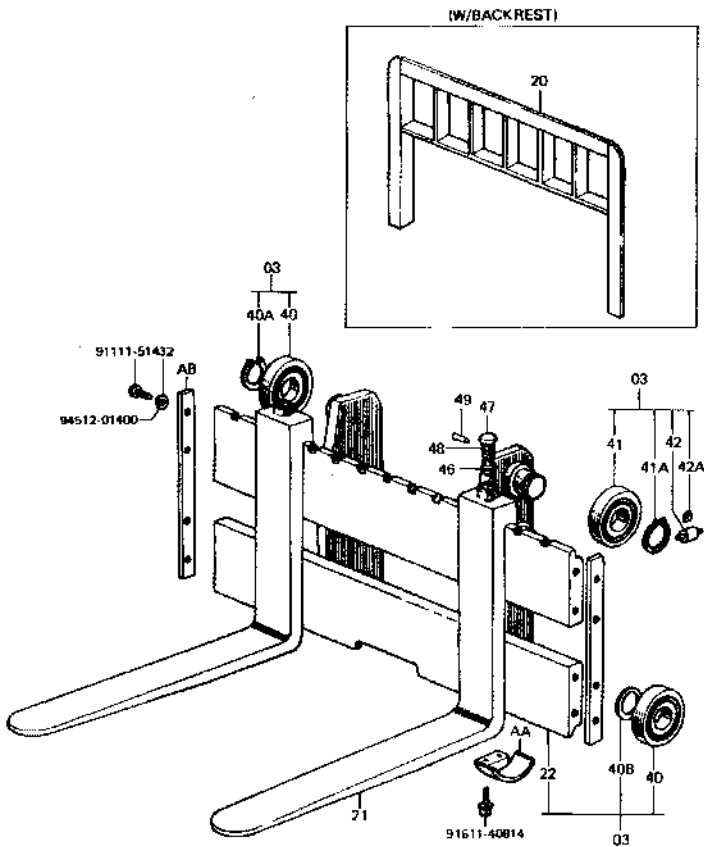

6301-001A

PART NAME CODE	PART NAME	QTY
6301-03	BRACKET ASSY, LIFT -----	1
6301-20	BACKREST SUB-ASSY -----	1
6301-21	FORK SUB-ASSY -----	2
6301-22	BRACKET SUB-ASSY, LIFT -----	1
6301-40	ROLLER, LIFT (UPPER, LOWER) -----	4
6301-40A	RING, SHAFT SNAP (UPPER, LOWER) -----	2
6301-40B	SHIM, LIFT ROLLER -----	99
6301-41	ROLLER, LIFT (CENTER) -----	2
6301-41A	RING, SHAFT SNAP (CENTER) -----	2
6301-42	ROLLER, SIDE -----	2
6301-42A	SHIM (FOR SIDE ROLLER) -----	99
6301-46	PIN, FORK STOPPER -----	2
6301-47	KNOB, FORK STOPPER PIN -----	2
6301-48	SPRING, FORK STOPPER PIN -----	2
6301-49	PIN, SPRING (FOR FORK STOPPER PIN) -----	2
6301-AA	COVER, LIFT BRACKET ROLLER -----	4
6301-AB	PLATE, SIDE -----	2

( F ) ( 2 )

G208

FIG. 6302 CHAIN & CHAIN WHEEL

**6302**

F

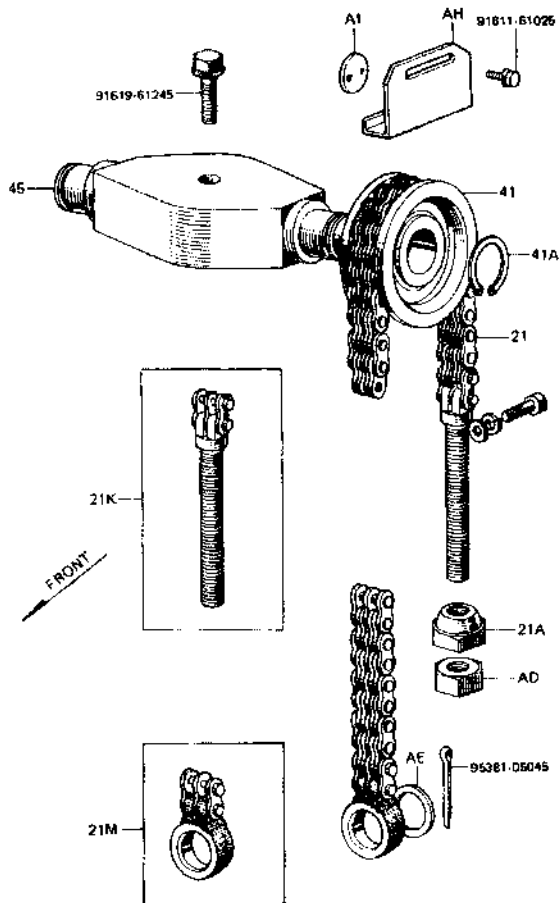

6302-001A

PART NAME CODE	PART NAME	QTY
6302-21	CHAIN SUB-ASSY (FRONT) -----	2
6302-21A	NUT, CHAIN ADJUST (FRONT) -----	2
6302-21K	BOLT KIT, CHAIN ANCHOR, NO.1 (FRONT) -----	2
6302-21M	BOLT KIT, CHAIN EYE (FRONT) -----	2
6302-41	WHEEL, CHAIN (FRONT) -----	2
6302-41A	RING, SHAFT SNAP (FOR FRONT CHAIN WHEEL) -----	2
6302-45	SUPPORT, CHAIN WHEEL -----	1
6302-AD	NUT, HEXAGON -----	2
6302-AE	WASHER, CHAIN SPECIAL -----	2
6302-AH	COVER, CHAIN WHEEL -----	2
6302-AI	SPACER -----	2

( F ) ( 3 )

G208

FIG. 6505 FRONT LIFT CYLINDER

**6505**

F

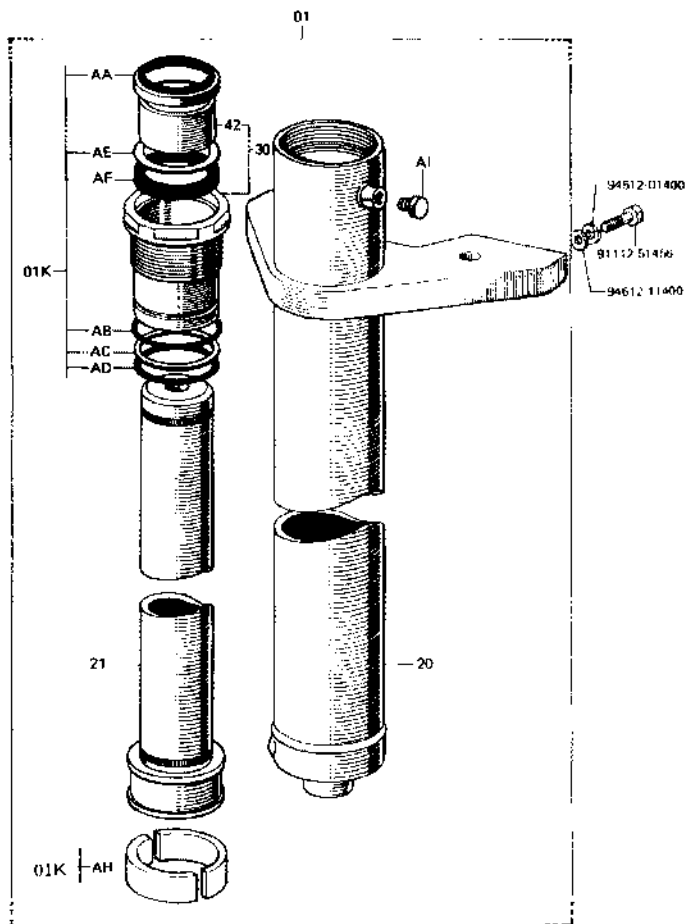

6505 007 A

PART NAME CODE	PART NAME	QTY
6505-01	CYLINDER ASSY, LIFT -----	1
6505-01K	CYLINDER O/H KIT, LIFT -----	1
6505-20	CYLINDER SUB-ASSY, LIFT -----	1
6505-21	ROD SUB-ASSY, LIFT CYLINDER -----	1
6505-30	GUIDE SUB-ASSY, LIFT CYLINDER ROD -----	1
6505-42	SLEEVE, LIFT CYLINDER ROD GUIDE -----	1
6505-AA	SEAL, DUST -----	1
6505-AB	RING, O -----	1
6505-AC	RING, BACK UP -----	1
6505-AD	RING, O -----	1
6505-AE	RING, BACK UP -----	1
6505-AF	PACKING, U -----	1
6505-AH	BUSHING -----	1
6505-AI	PLUG -----	1

( F ) ( 4 )

G208

FIG. 6506 REAR LIFT CYLINDER

**6506**

F

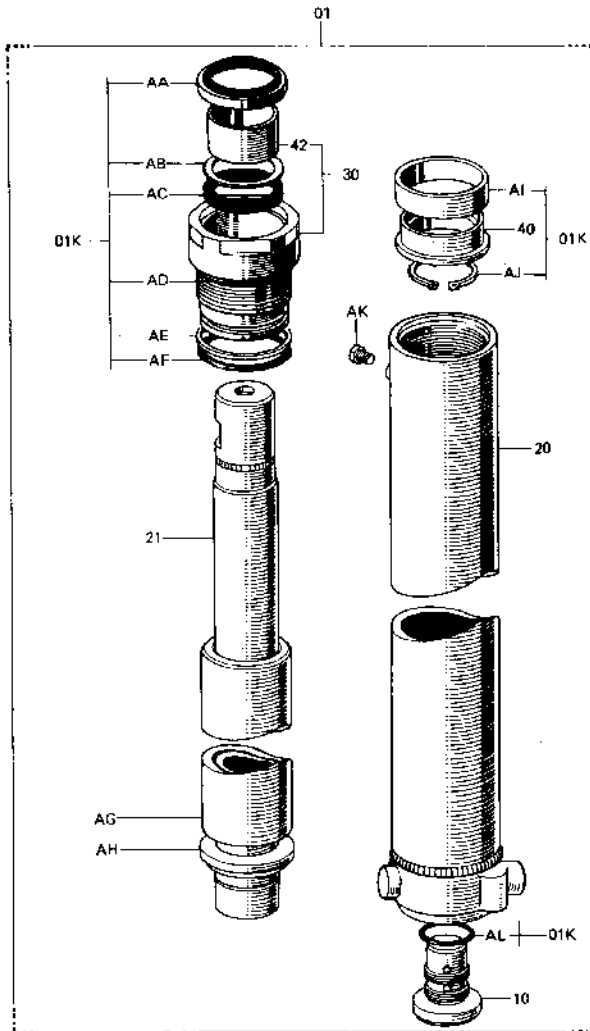

6506-001

PART NAME CODE	PART NAME	QTY
6506-01	CYLINDER ASSY, LIFT -----	1
6506-01K	CYLINDER O/H KIT, LIFT -----	1
6506-10	VALVE ASSY, FLOW REGULATOR -----	1
6506-20	CYLINDER SUB-ASSY, LIFT -----	1
6506-21	ROD SUB-ASSY, LIFT CYLINDER -----	1
6506-30	GUIDE SUB-ASSY, CYLINDER ROD -----	1
6506-40	PISTON, LIFT CYLINDER -----	1
6506-42	SLEEVE, LIFT CYLINDER ROD GUIDE -----	1
6506-AA	SEAL, DUST -----	1
6506-AB	RING, BACK UP -----	1
6506-AC	PACKING, U -----	1
6506-AD	RING, O -----	1
6506-AE	RING, BACK UP -----	1
6506-AF	RING, O -----	1
6506-AG	SPACER, LIFT CYLINDER -----	1
6506-AH	RING, SPACER -----	1
6506-AI	RING, WEAR -----	1
6506-AJ	RING, SHAFT SNAP -----	1
6506-AK	PLUG -----	1
6506-AL	RING, O -----	1

FIG. 6511 TILT CYLINDER

6511

F

F

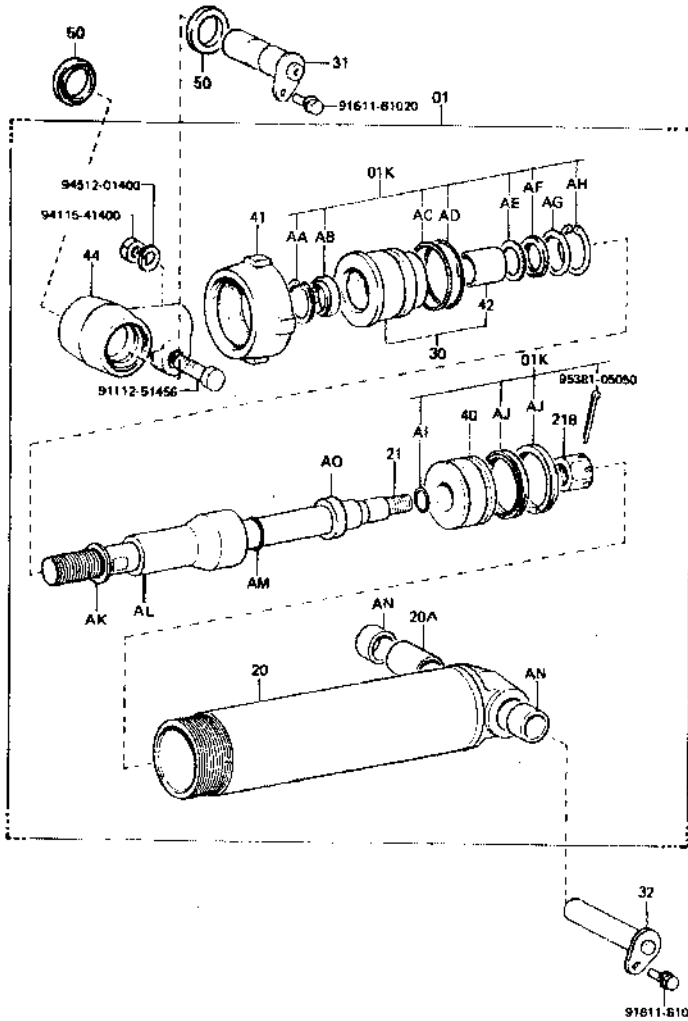

6511-010

テイルト角度表  
TABLE OF TILT RANGE

生産期間 PROD DATE	型式 MODELS	タイヤ TIRE	揚高 LIFTING HEIGHT	備考 DESCRIPTION	テイルト角 TILT RANGE
8003-	F, FV, M, SV, V	SINGLE	H2000-H4000		6D - 12D
8003-	F, FV, M, SV, V	DOUBLE	H2000-H4500		6D - 12D
8003-	F, FV, M, SV, V	SINGLE	H4500-H5000		6D - 6D
8003-	F, FV, M, SV, V	DOUBLE	H5000		6D - 6D
8003-	F, FV, M, SV, V		H2000	FRONT GLASS	6D - 10D
8003-	FSV, FS		H3700-H4700	DOMESTIC	6D - 6D
8003-	FSV, FS		H5000-H8500	DOMESTIC	3D - 8D
8003-	FSV, FS		H3700-H6500	EXPORT	6D - 6D
8003-	F, FV, M, SV, V	SINGLE	H2000-H4000	AUSTRALIA	3D 12D
8003-	F, FV, M, SV, V	DOUBLE	H2000-H4500	AUSTRALIA	3D - 12D
8003-	F, FV, M, SV, V	SINGLE	H4500-H5000	AUSTRALIA	3D - 6D
8003-	F, FV, M, SV, V	DOUBLE	H5000	AUSTRALIA	3D - 6D
8003-	F, FV, M, SV, V		H2000	FRONT GLASS AUSTRALIA	3D - 8D
8003-	FV, M, SV, V		H3700-H6500	AUSTRALIA	3D - 6D

6511-018

FIG. 6511 TILT CYLINDER

# 6511

F

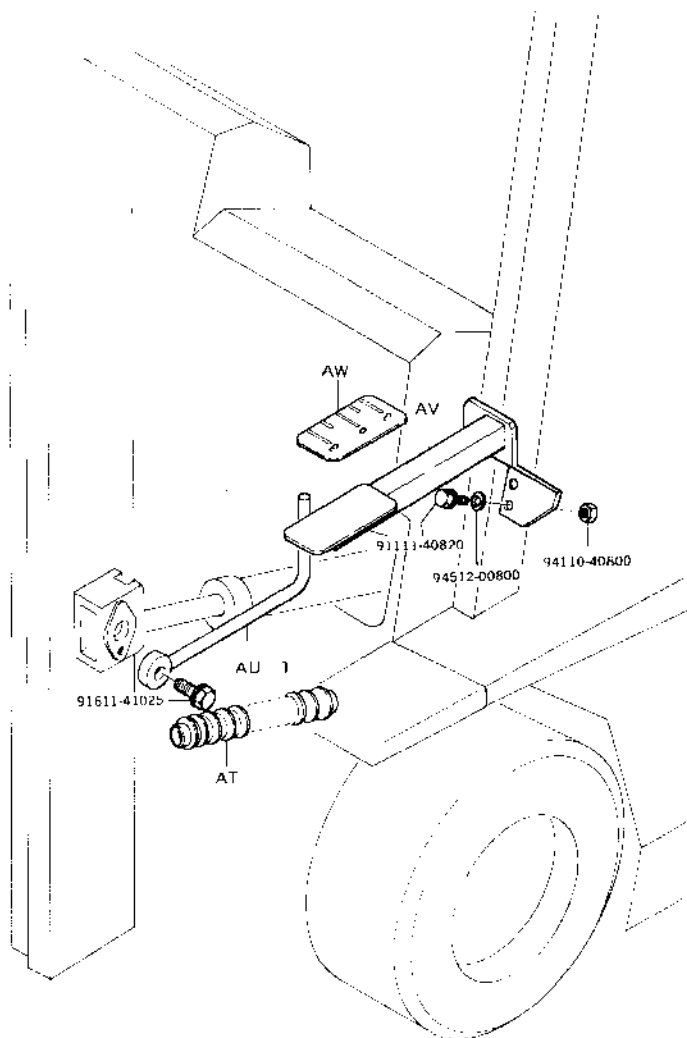

6511-013

PART NAME CODE	PART NAME	QTY
6511-01	CYLINDER ASSY, TILT -----	2
6511-01K	CYLINDER O/H KIT, TILT -----	2
6511-20	CYLINDER SUB-ASSY, TILT -----	2
6511-20A	BUSH, PIN (FOR CYLINDER) -----	2
6511-21	ROD SUB-ASSY, TILT CYLINDER PISTON -----	2
6511-21B	NUT, CASTLE -----	2
6511-30	GUIDE SUB-ASSY, TILT CYLINDER ROD -----	2
6511-31	PIN SUB-ASSY, TILT CYLINDER, FR -----	2
6511-32	PIN SUB-ASSY, TILT CYLINDER, RR -----	2
6511-40	PISTON, TILT CYLINDER -----	2
6511-41	COVER, TILT CYLINDER -----	2
6511-42	SLEEVE, TILT CYLINDER ROD GUIDE -----	2
6511-44	JOINT, PISTON ROD -----	2
6511-50	SEAL, GREASE -----	4
6511-AA	RING, HOLE SNAP -----	2
6511-AB	SEAL, DUST -----	2
6511-AC	RING, BACK UP -----	2
6511-AD	RING, O -----	2
6511-AE	RING, BACK UP -----	2
6511-AF	PACKING, U -----	2
6511-AG	PLATE, STOPPER -----	2
6511-AH	RING, HOLE SNAP -----	2
6511-AI	RING, O -----	2
6511-AJ	PACKING, U -----	4
6511-AK	SHIM, TILT CONTROL -----	99
6511-AL	SPACER, TILT CONTROL -----	2
6511-AM	RING, O -----	4
6511-AN	COLLAR -----	4
6511-AO	SPACER, TILT CONTROL -----	2
6511-AT	BOOT SUB-ASSY -----	2
6511-AU	BAR SUB-ASSY, TILT GAUGE -----	1
6511-AV	BRACKET SUB-ASSY, TILT GAUGE -----	1
6511-AW	PLATE, TILT CYLINDER INDICATOR -----	1



FIG. 6701 OIL PUMP

**6701**

F

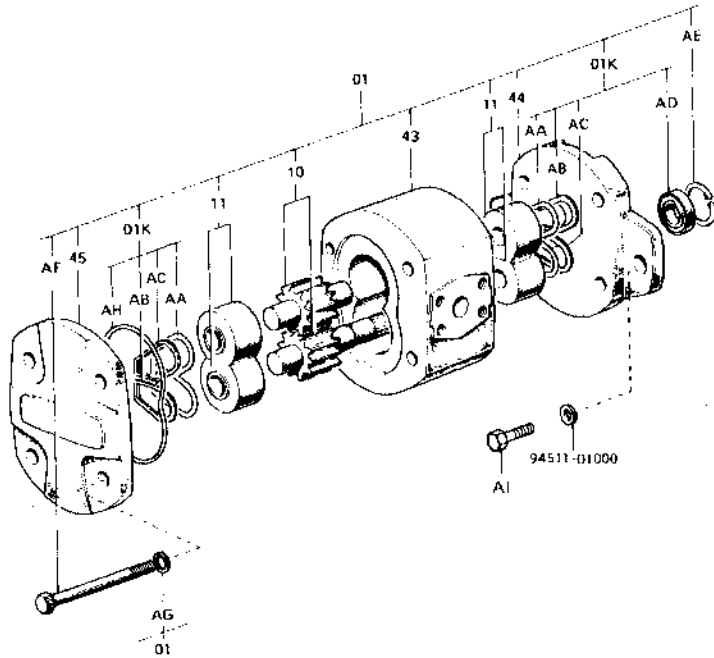

PART NAME CODE	PART NAME	QTY
6701-01	PUMP ASSY, OIL -----	1
6701-01K	PUMP O/H KIT, OIL -----	1
6701-10	GEAR SET -----	1
6701-11	BUSH SET, NO.1 -----	2
6701-43	BODY -----	1
6701-44	FLANGE, MOUNTING -----	1
6701-45	COVER -----	1
6701-AA	SEAL, BUSHING -----	2
6701-AB	RING, BACKING, RH -----	2
6701-AC	RING, BACKING, LH -----	2
6701-AD	SEAL, OIL -----	1
6701-AE	RING, SNAP -----	1
6701-AF	BOLT -----	4
6701-AG	WASHER, SPRING -----	4
6701-AH	SEAL, BODY -----	2
6701-AI	BOLT -----	2

6701-01K

FIG. 6705 OIL CONTROL VALVE

6705

F (UL)

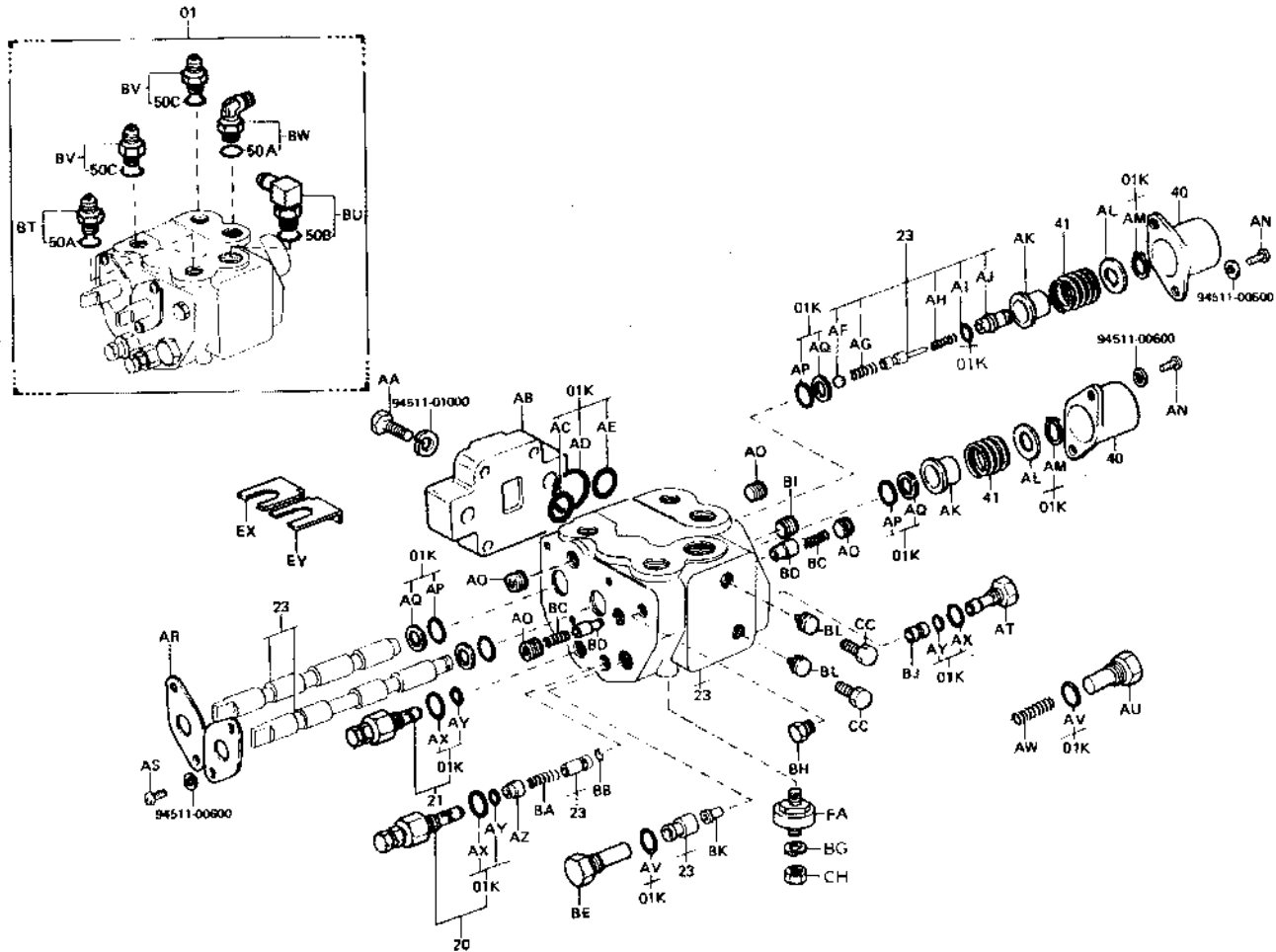

FIG. 6705 OIL CONTROL VALVE

6705

F

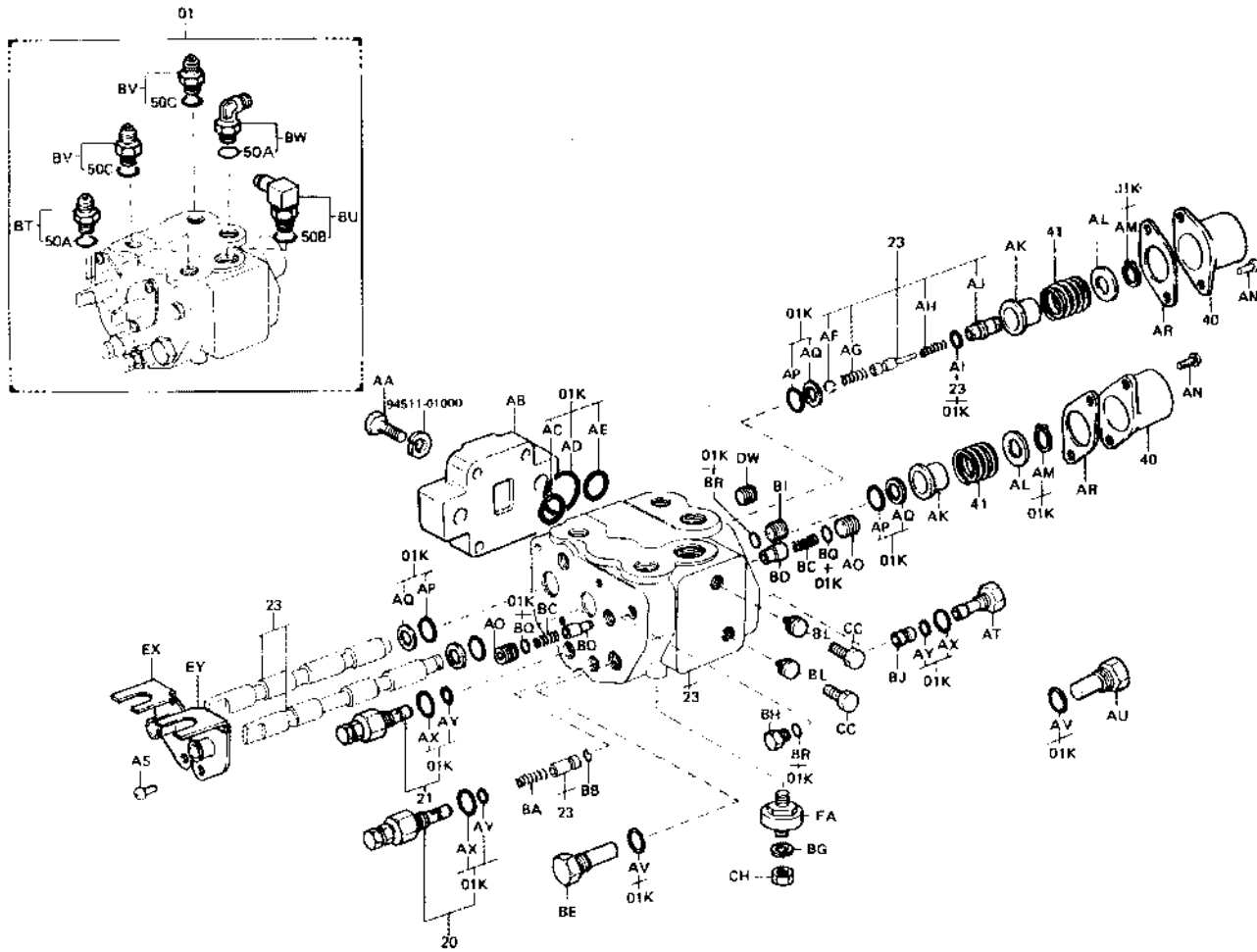

FIG. 6705 OIL CONTROL VALVE

6705

F (3-WAY..UL)

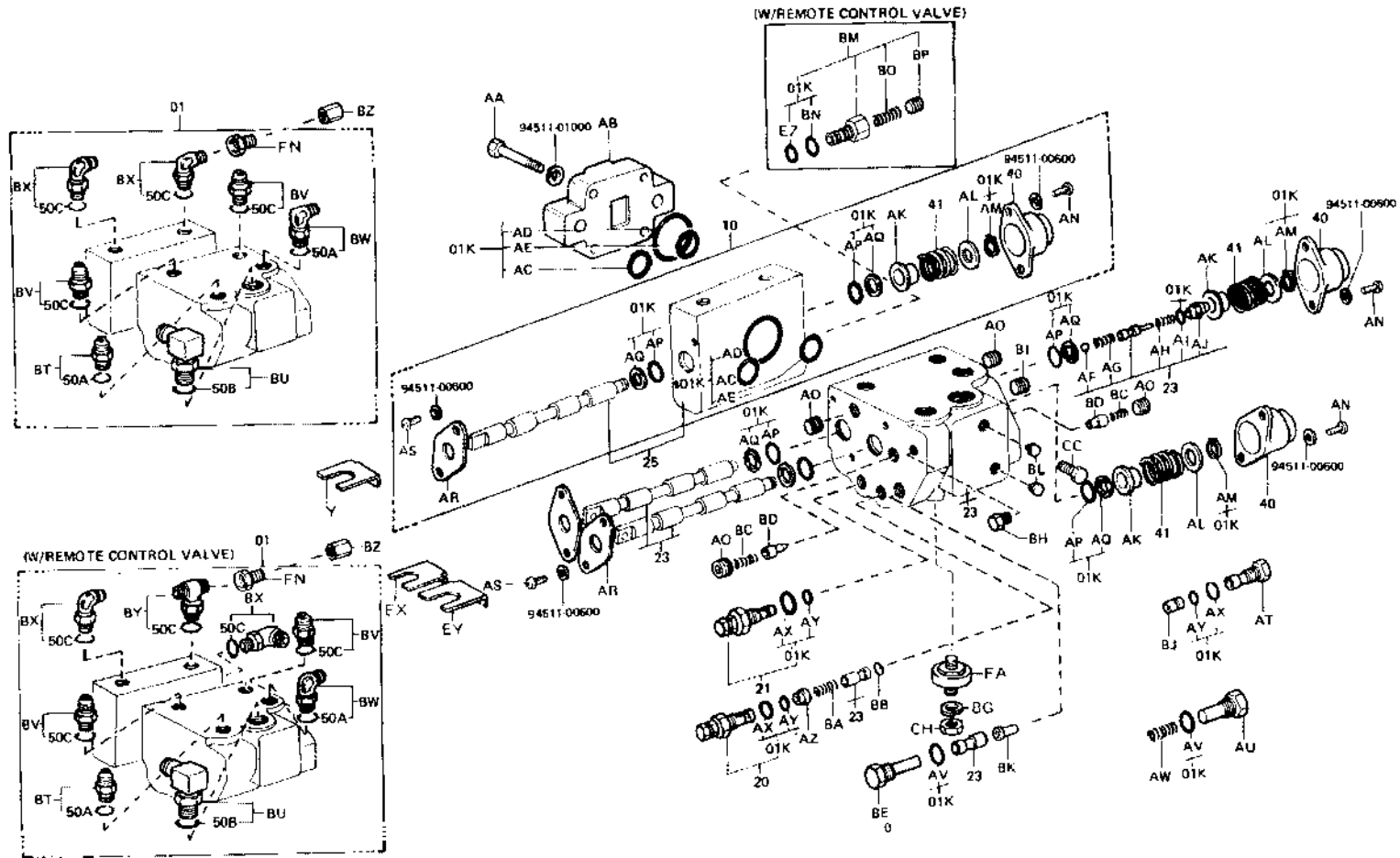

FIG. 6705 OIL CONTROL VALVE

# 6705

F (3-WAY)

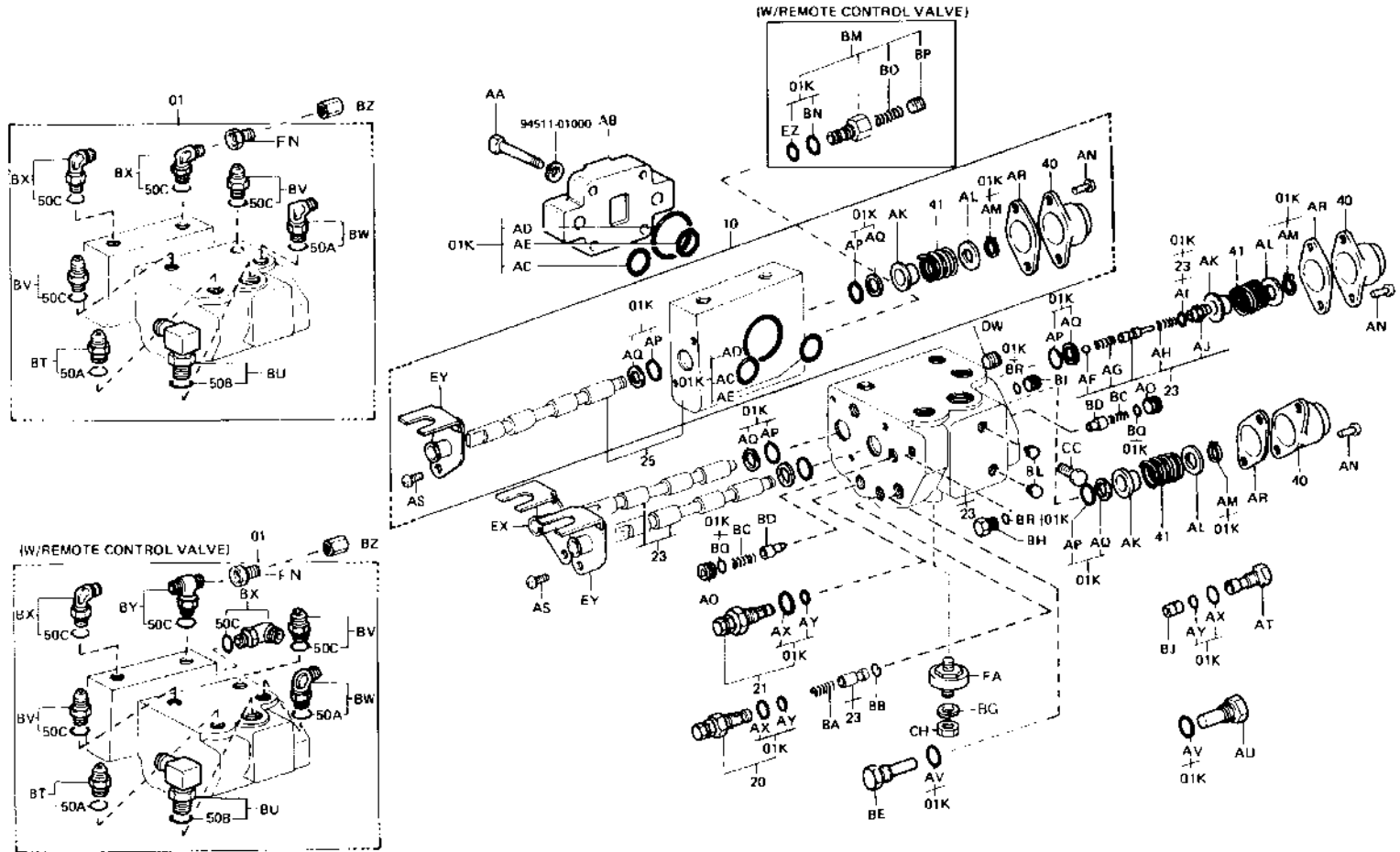

FIG. 6705 OIL CONTROL VALVE

6705

F (4-WAY)

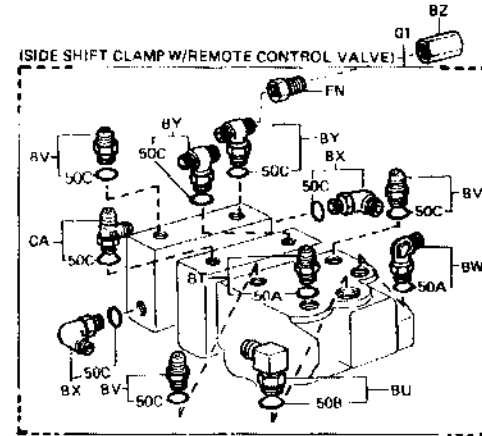
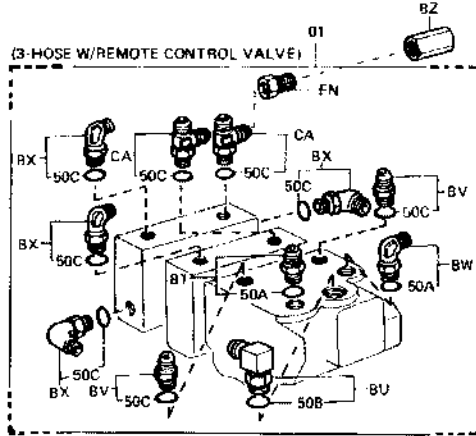
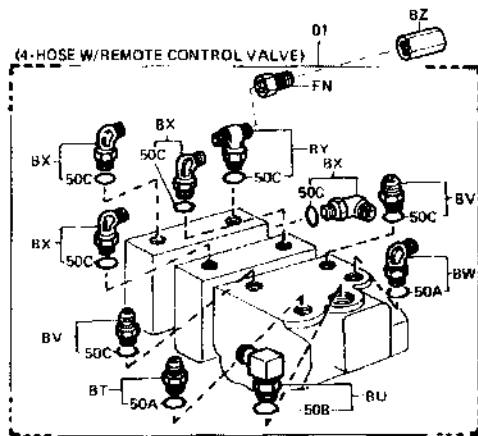
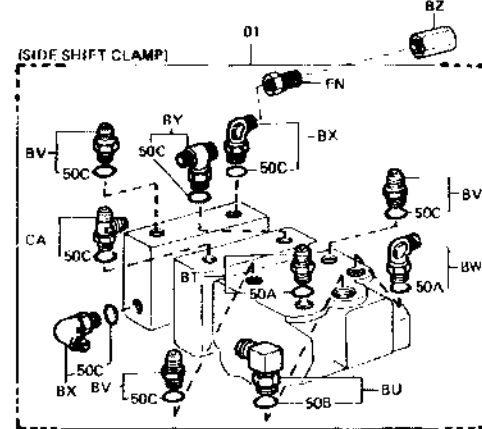
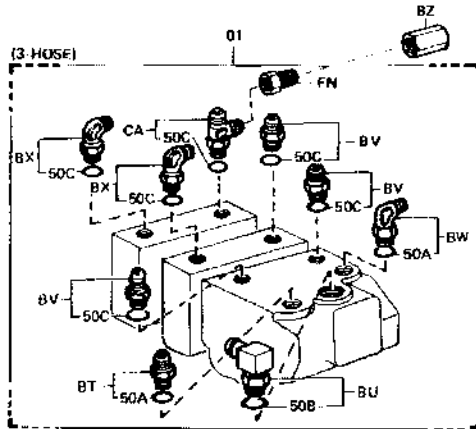
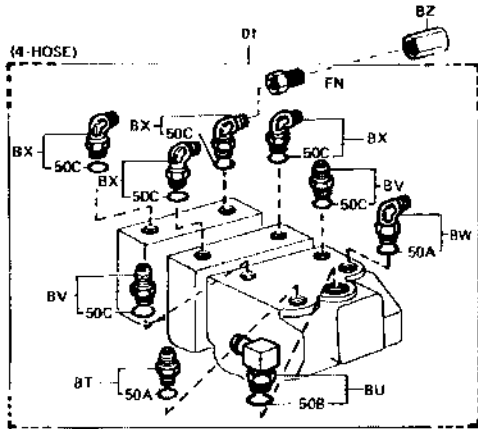
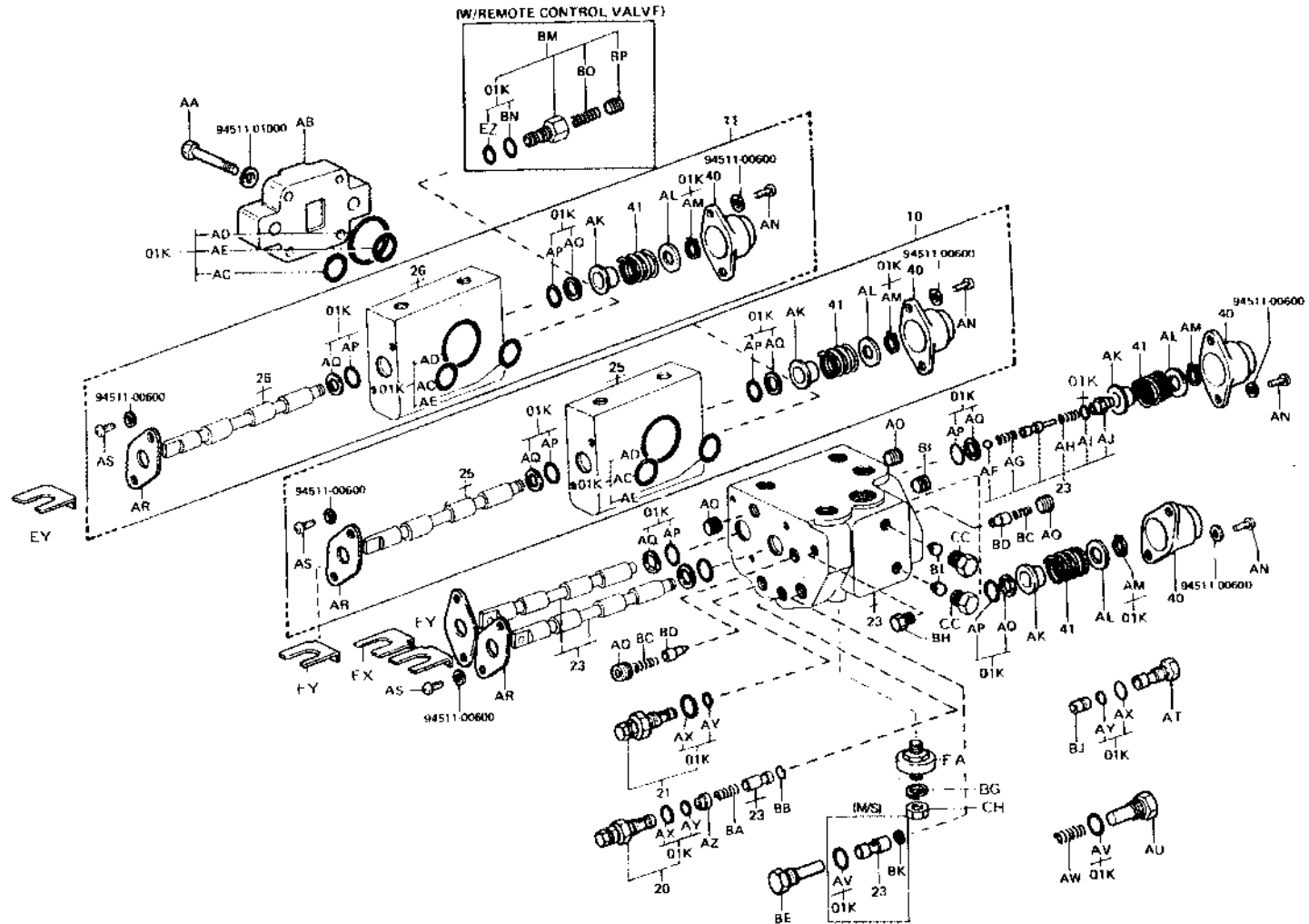

FIG. 6705 OIL CONTROL VALVE

6705

F (4-WAY..UL)







# 6705

PART NAME CODE	PART NAME	QTY
6705-01	VALVE ASSY, OIL CONTROL -----	1
6705-01K	VALVE O/H KIT, OIL CONTROL -----	1
6705-10	VALVE ASSY, PLUNGER SECTION, NO.1 -----	1
6705-11	VALVE ASSY, PLUNGER SECTION, NO.2 -----	1
6705-20	VALVE SET, PILOT RELIEF, NO.1 -----	1
6705-21	VALVE SET, PILOT RELIEF, NO.2 -----	1
6705-23	HOUSING & SPOOL SET, NO.1 -----	1
6705-25	HOUSING & SPOOL SET, ATTACHMENT, NO.1 -----	1
6705-26	HOUSING & SPOOL SET, ATTACHMENT, NO.2 -----	1
6705-40	COVER, SPRING -----	2
6705-41	SPRING, COMPRESSION (FOR SPOOL RETURN) -----	2
6705-50A	RING, O, NO.1 (FOR VALVE FITTING) -----	2
6705-50B	RING, O, NO.2 (FOR VALVE FITTING) -----	1
6705-50C	RING, O, NO.3 (FOR VALVE FITTING) -----	2
6705-AA	BOLT -----	4
6705-AB	HOUSING, OUTLET -----	1
6705-AC	RING, O -----	1
6705-AD	RING, O -----	1
6705-AE	RING, O -----	1
6705-AF	BALL, STEEL -----	1
6705-AG	SPRING -----	1
6705-AH	SPRING, COMPRESSION -----	1
6705-AI	RING, O -----	1
6705-AJ	STOPPER -----	1
6705-AK	HOLDER, SPRING -----	2
6705-AL	WASHER, PLATE -----	2
6705-AM	RING, SHAFT SNAP -----	2
6705-AN	SCREW -----	4
6705-AO	PLUG -----	2
6705-AP	RING, O -----	4
6705-AQ	RING, BACK UP -----	4
6705-AR	HOLDER, SEAL -----	2
6705-AS	SCREW -----	4
6705-AT	STOPPER -----	1
6705-AU	STOPPER -----	1
6705-AV	RING, O -----	2
6705-AW	SPRING, COMPRESSION -----	1
6705-AX	RING, O -----	3
6705-AY	RING, O -----	3
6705-AZ	COLLAR -----	1
6705-BA	SPRING, COMPRESSION -----	1
6705-BB	WIRE, DRIFICE TURNING -----	1
6705-BC	SPRING, COMPRESSION -----	2
6705-BD	PLUNGER, CHECK -----	2
6705-BE	STOPPER -----	1
6705-BG	WASHER -----	4
6705-BH	PLUG -----	1
6705-BI	PLUG -----	1
6705-BJ	SEAT, VALVE -----	1
6705-BK	VALVE, CHECK -----	1
6705-BL	SEAT, INSERT -----	2
6705-BM	VALVE SUB-ASSY, RELIEF -----	1
6705-BN	RING, O -----	1

( F ) ( 8 )

G208

PART NAME CODE	PART NAME	QTY
6705-B0	SPRING -----	1
6705-BP	STOPPER -----	1
6705-BQ	RING, O -----	2
6705-BR	RING, O -----	2
6705-BT	FITTING -----	1
6705-BU	FITTING -----	1
6705-BV	FITTING -----	2
6705-BW	FITTING -----	1
6705-BX	FITTING -----	2
6705-BY	FITTING -----	1
6705-BZ	PLUG -----	2
6705-CA	FITTING -----	1
6705-CC	PLUG -----	2
6705-CH	NUT -----	4
6705-CW	PLUG -----	1
6705-EX	BRACKET SUB-ASSY, TILT -----	1
6705-EY	BRACKET SUB-ASSY, LIFT -----	1
6705-EZ	RING, O -----	1
6705-FA	INSULATOR -----	4
6705-FN	FITTING -----	2

( F ) ( 9 )

G208

FIG. 6709 OIL CONTROL VALVE LINK

6709

F

F (3-WAY)

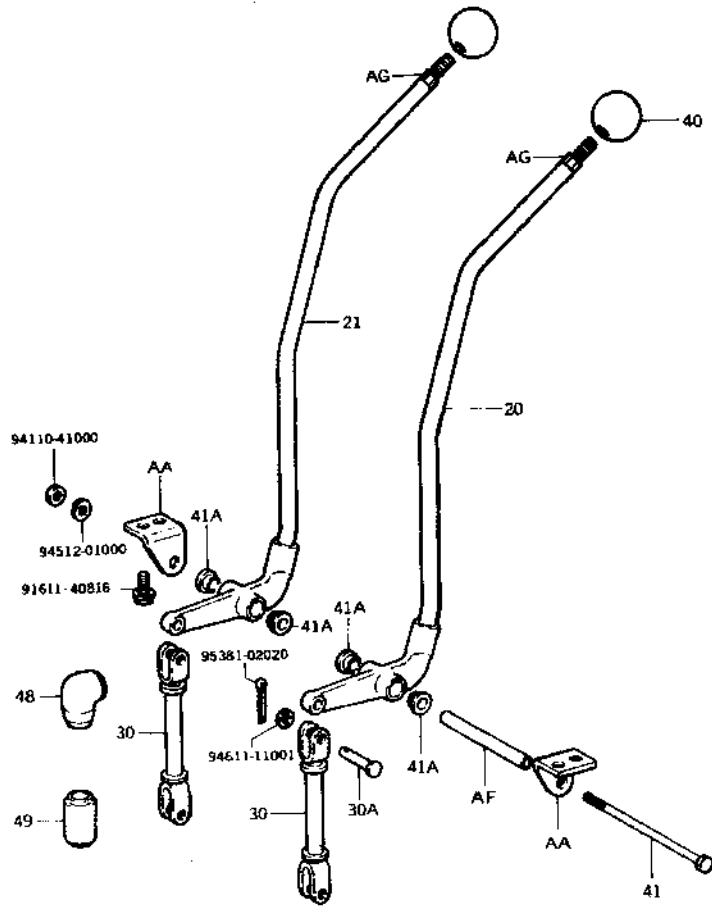

6709-016

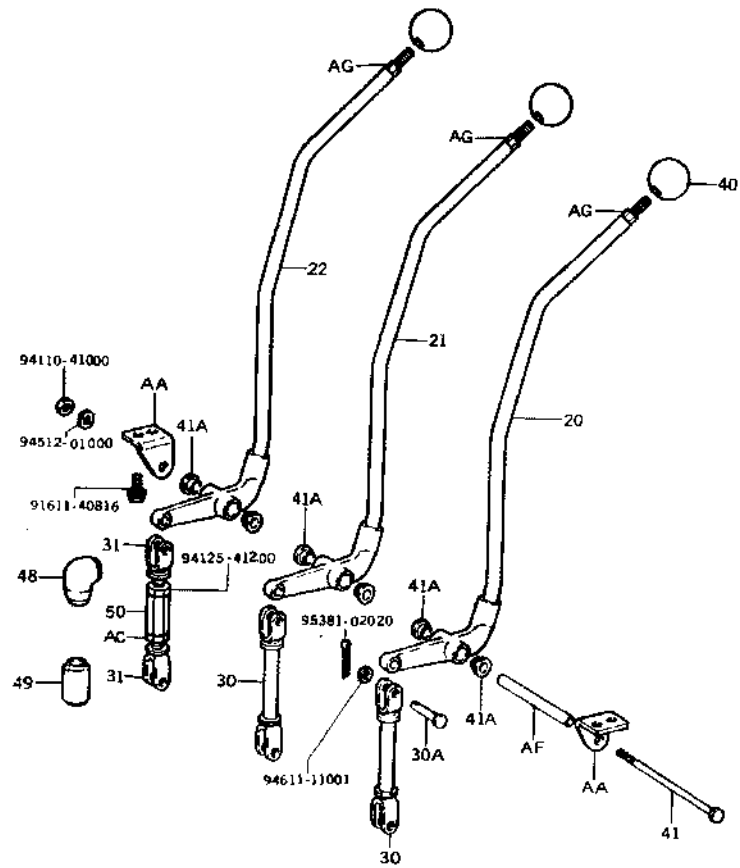

6709-017

FIG. 6709 OIL CONTROL VALVE LINK

**6709**

F (4-WAY)

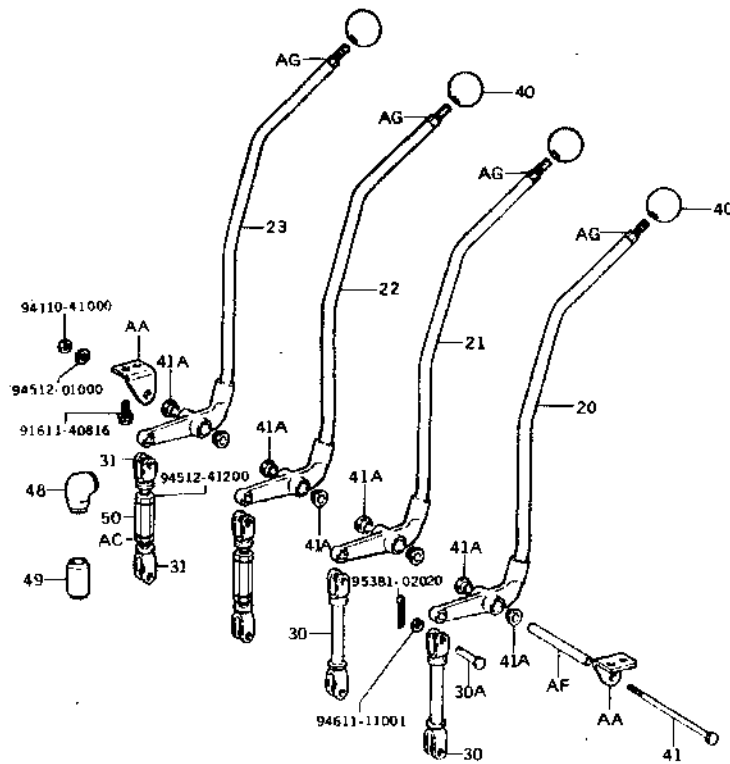

6709-010

PART NAME CODE	PART NAME	QTY
6709-20	LEVER SUB-ASSY, CONTROL VALVE, NO.1	1
6709-21	LEVER SUB-ASSY, CONTROL VALVE, NO.2	1
6709-22	LEVER SUB-ASSY, CONTROL VALVE, NO.3	1
6709-23	LEVER SUB-ASSY, CONTROL VALVE, NO.4	1
6709-30	ROD SUB-ASSY, CONTROL VALVE LEVER, NO.1	1
6709-30A	PIN (FOR CONTROL VALVE LEVER ROD)	4
6709-31	ROD SUB-ASSY, CONTROL VALVE LEVER, NO.2	1
6709-40	KNOB, OIL CONTROL VALVE LEVER	2
6709-41	PIN, OIL CONTROL VALVE LEVER	1
6709-41A	BUSH (FOR LEVER PIN)	4
6709-48	BOOT, CONTROL VALVE LINK, NO.1	2
6709-49	BOOT, CONTROL VALVE LINK, NO.2	2
6709-50	TURNBUCKLE	1
6709-AA	BRACKET SUB-ASSY	1
6709-AC	NUT	1
6709-AF	SPACER	1
6709-AG	BOLT, STUD	2

(F ) ( 10)

G208

FIG. 8801 BODY PIPING

6801

F

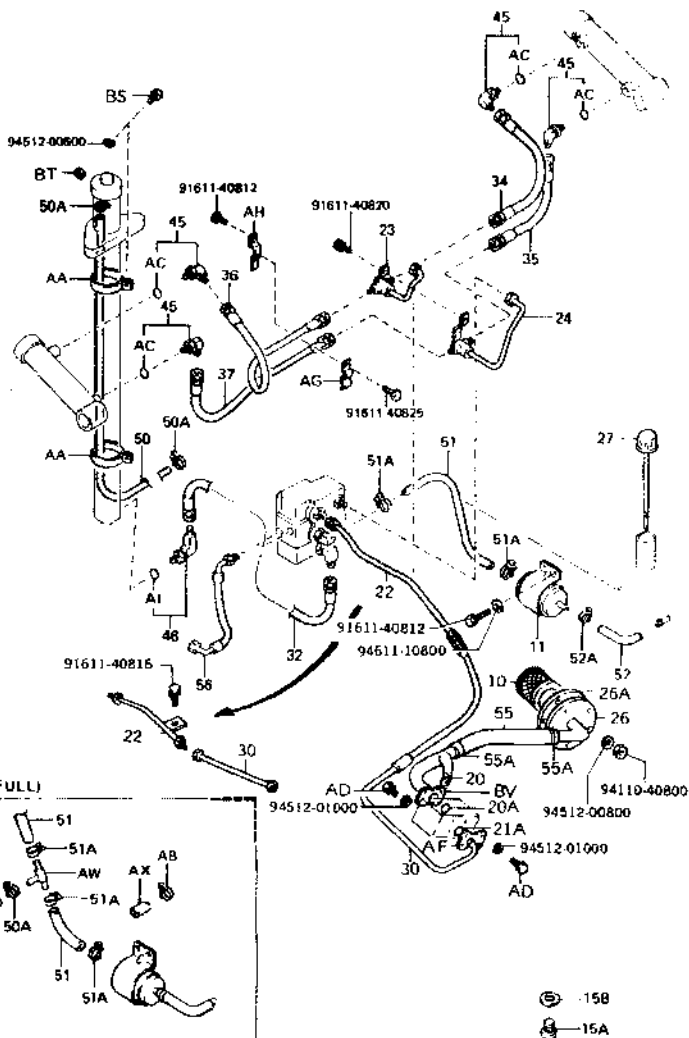

6801 011

PART NAME CODE	PART NAME	QTY
6801-10	FILTER ASSY, SUCTION	1
6801-11	FILTER ASSY, RETURN	1
6801-15A	PLUG (FOR OIL TANK DRAIN)	1
6801-15B	GASKET (FOR OIL TANK DRAIN PLUG)	1
6801-20	PIPE SUB-ASSY (PUMP INLET)	1
6801-20A	RING, O (FOR OIL PUMP INLET)	1
6801-21A	RING, O (FOR OIL PUMP OUTLET)	1
6801-22	PIPE SUB-ASSY (PUMP TO VALVE)	1
6801-23	PIPE SUB-ASSY (TILT CYLINDER FRONT)	1
6801-24	PIPE SUB-ASSY (TILT CYLINDER REAR)	1
6801-26	OUTLET SUB-ASSY, OIL TANK	1
6801-26A	PACKING, OIL TANK COVER	1
6801-27	CAP SUB-ASSY, OIL TANK	1
6801-30	HOSE, HIGH PRESSURE, NO.1 (PUMP TO VALVE)	1
6801-32	HOSE, HIGH PRESSURE, NO.1 (VALVE TO LIFT)	1
6801-34	HOSE, HIGH PRESSURE, NO.1 (TILT FRONT)	1
6801-35	HOSE, HIGH PRESSURE, NO.1 (TILT REAR)	1
6801-36	HOSE, HIGH PRESSURE, NO.2 (TILT FRONT)	1
6801-37	HOSE, HIGH PRESSURE, NO.2 (TILT REAR)	1
6801-45	FITTING (FOR TILT CYLINDER)	2
6801-46	FITTING (FOR LIFT CYLINDER)	1
6801-51	HOSE, LOW PRESSURE, NO.1 (VALVE TO TANK)	1
6801-51A	CLAMP (FOR VALVE TO TANK NO.1 HOSE)	2
6801-52	HOSE, LOW PRESSURE, NO.2 (VALVE TO TANK)	1
6801-52A	CLAMP (FOR VALVE TO TANK NO.2 HOSE)	2
6801-55	HOSE, LOW PRESSURE (TANK TO PUMP)	1
6801-55A	CLAMP (FOR TANK TO PUMP HOSE)	2
6801-56	HOSE, LOW PRESSURE (STEERING TO VALVE)	1
6801-AC	RING, O	4
6801-AD	BOLT	8
6801-AF	FLANGE, SPLIT	1
6801-AG	CLAMP	1
6801-AH	BRACKET SUB-ASSY, TILT HOSE	1
6801-BS	BOLT	5
6801-BT	WASHER	5
6801-BV	FLANGE	2

(F) ( 11)

G208

FIG. 6802 MAST PIPING

**6802**

F

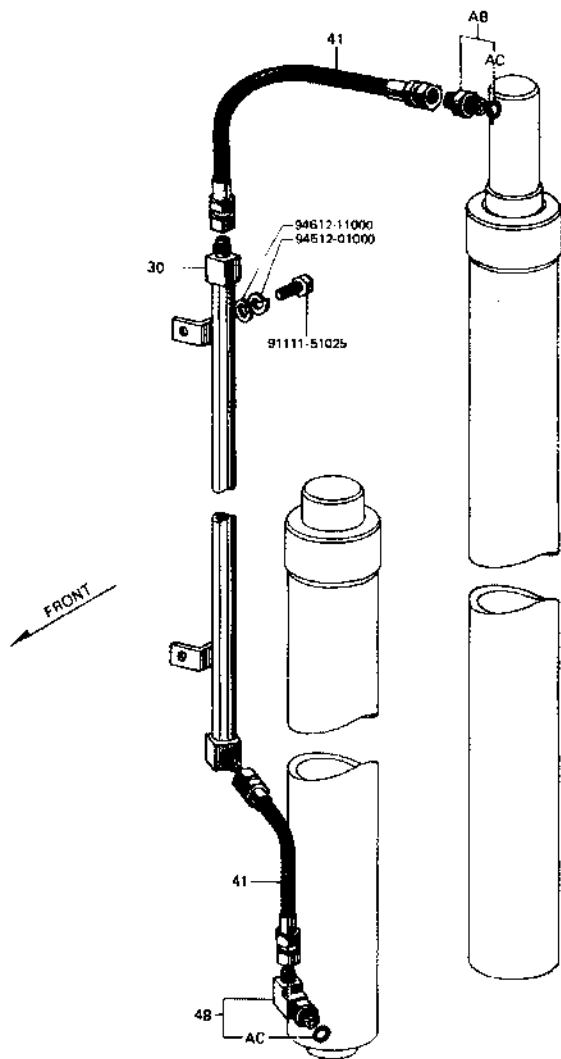

PART NAME CODE	PART NAME	QTY
6802-30	PIPE SUB-ASSY, NO.1 (FRONT LIFT) -----	1
6802-41	HOSE, HIGH PRESSURE, NO.1 (FRONT LIFT) -----	2
6802-48	FITTING (FOR FRONT LIFT CYLINDER) -----	1
6802-AB	FITTING -----	1
6802-AC	RING, O -----	2

6802-001

FIG. 6101 MAST

6101

FS

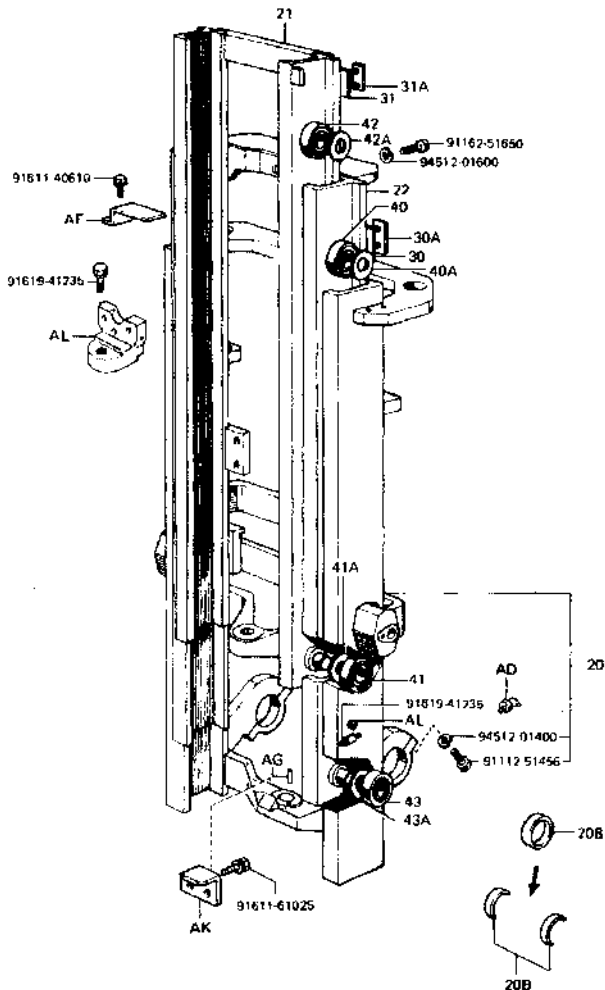

PART NAME CODE	PART NAME	QTY
6101-20	MAST SUB-ASSY, OUTER -----	1
6101-20B	BUSH, MAST SUPPORT -----	1
6101-21	MAST SUB-ASSY, INNER -----	1
6101-22	MAST SUB-ASSY, MIDDLE -----	1
6101-30	STRIP SUB-ASSY, OUTER MAST -----	2
6101-30A	SHIM, OUTER MAST STRIP -----	99
6101-31	STRIP SUB-ASSY, MIDDLE MAST -----	2
6101-31A	SHIM, MIDDLE MAST STRIP -----	99
6101-40	ROLLER, LIFT (FOR OUTER MAST) -----	2
6101-40A	SHIM, LIFT ROLLER (FOR OUTER MAST) -----	99
6101-41	ROLLER, LIFT (FOR INNER MAST) -----	2
6101-41A	SHIM, LIFT ROLLER (FOR INNER MAST) -----	99
6101-42	ROLLER, LIFT (FOR MIDDLE MAST UPPER) -----	2
6101-42A	SHIM, LIFT ROLLER (FOR MIDDLE MAST UPPER) --	99
6101-43	ROLLER, LIFT (FOR MIDDLE MAST LOWER) -----	2
6101-43A	SHIM, LIFT ROLLER (FOR MIDDLE MAST LOWER) --	99
6101-AD	FITTING, GREASE -----	2
6101-AF	COVER, ROLLER -----	2
6101-AG	PIN, SPRING -----	1
6101-AK	STOPPER, REAR CYLINDER -----	1
6101-AL	TOP, LIFT CYLINDER -----	1

6101-068

(FS) ( 1 )

G208

FIG. 6301 LIFT BRACKET & FORK

6301

FS

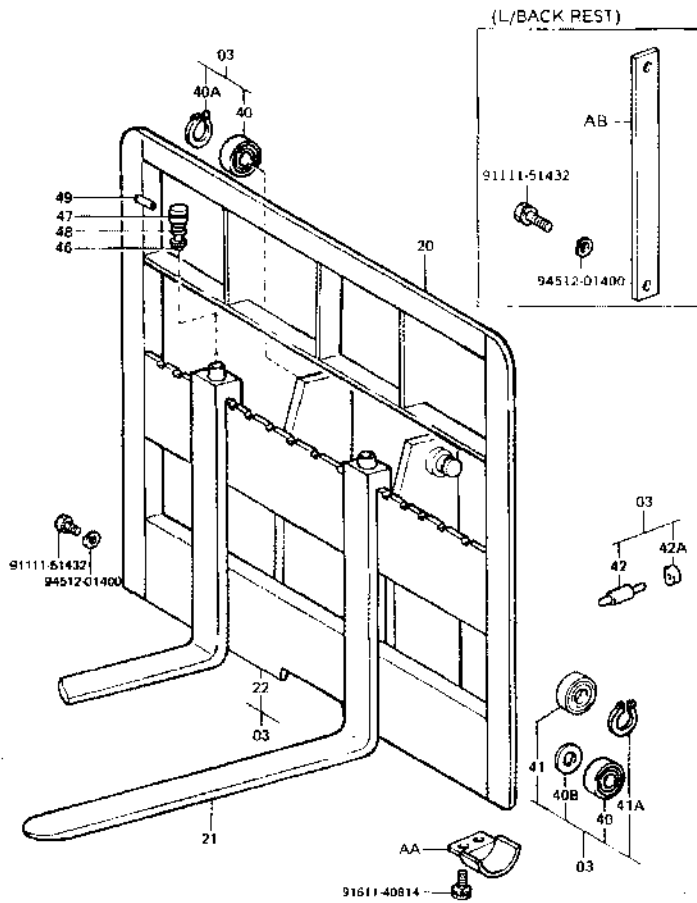

6301-002A

PART NAME CODE	PART NAME	QTY
6301-03	BRACKET ASSY, LIFT -----	1
6301-20	BACKREST SUB-ASSY -----	1
6301-21	FORK SUB-ASSY -----	2
6301-22	BRACKET SUB-ASSY, LIFT -----	1
6301-40	ROLLER, LIFT (UPPER, LOWER) -----	4
6301-40A	RING, SHAFT SNAP (UPPER, LOWER) -----	2
6301-40B	SHIM, LIFT ROLLER -----	99
6301-41	ROLLER, LIFT (CENTER) -----	2
6301-41A	RING, SHAFT SNAP (CENTER) -----	2
6301-42	ROLLER, SIDE -----	2
6301-42A	SHIM (FOR SIDE ROLLER) -----	99
6301-46	PIN, FORK STOPPER -----	2
6301-47	KNOB, FORK STOPPER PIN -----	2
6301-48	SPRING, FORK STOPPER PIN -----	2
6301-49	PIN, SPRING (FOR FORK STOPPER PIN) -----	2
6301-AA	COVER, LIFT BRACKET ROLLER -----	4
6301-AB	PLATE, SIDE -----	2

(FS ) ( 2)

G208

FIG. 6302 CHAIN & CHAIN WHEEL

**6302**

FS

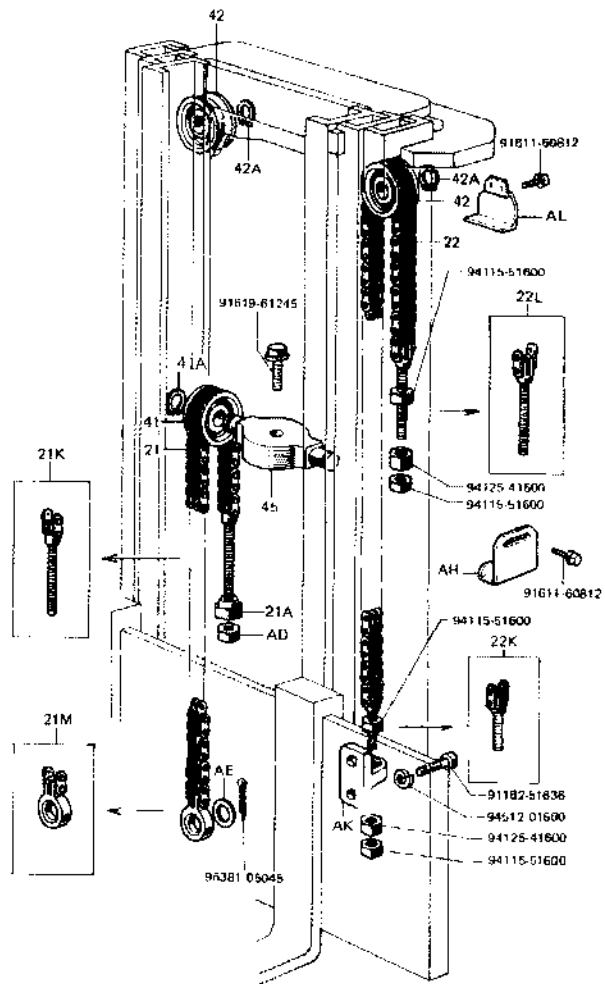

6302.D07A

PART NAME CODE	PART NAME	QTY
6302-21	CHAIN SUB-ASSY (FRONT) -----	2
6302-21A	NUT, CHAIN ADJUST (FRONT) -----	2
6302-21K	BOLT KIT, CHAIN ANCHOR, NO.1 (FRONT) -----	2
6302-21M	BOLT KIT, CHAIN EYE (FRONT) -----	2
6302-22	CHAIN SUB-ASSY (REAR) -----	2
6302-22K	BOLT KIT, CHAIN ANCHOR, NO.1 (REAR) -----	2
6302-22L	BOLT KIT, CHAIN ANCHOR, NO.2 (REAR) -----	2
6302-41	WHEEL, CHAIN (FRONT) -----	2
6302-41A	RING, SHAFT SNAP (FOR FRONT CHAIN WHEEL) ---	2
6302-42	WHEEL, CHAIN (REAR) -----	2
6302-42A	RING, SHAFT SNAP (FOR CHAIN WHEEL) -----	2
6302-45	SUPPORT, CHAIN WHEEL -----	1
6302-AD	NUT, HEXAGON -----	2
6302-AE	WASHER, CHAIN SPECIAL -----	2
6302-AH	COVER, CHAIN WHEEL -----	2
6302-AK	PLATE, CHAIN ANCHOR -----	2
6302-AL	COVER, CHAIN WHEEL -----	2

(FS) ( 3 )

G208



FIG. 6505 FRONT LIFT CYLINDER

# 6505

FS

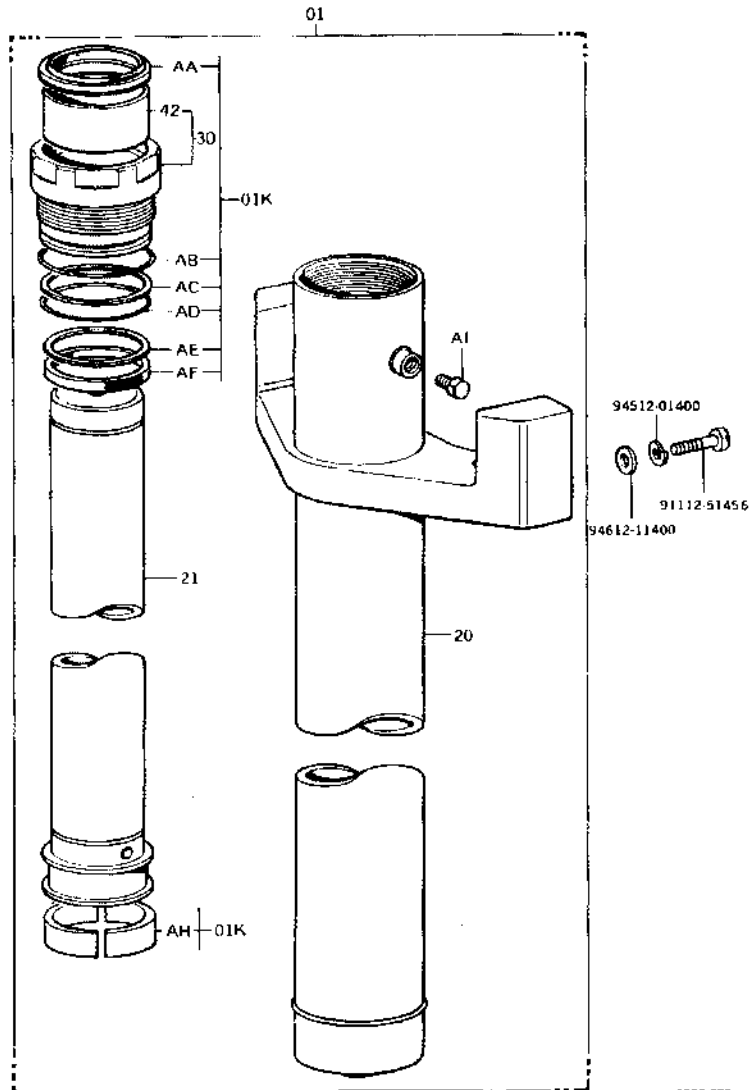

6505-006

PART NAME CODE	PART NAME	QTY
6505-01	CYLINDER ASSY, LIFT -----	1
6505-01K	CYLINDER O/H KIT, LIFT -----	1
6505-20	CYLINDER SUB-ASSY, LIFT -----	1
6505-21	ROD SUB-ASSY, LIFT CYLINDER -----	1
6505-30	GUIDE SUB-ASSY, LIFT CYLINDER ROD -----	1
6505-42	SLEEVE, LIFT CYLINDER ROD GUIDE -----	1
6505-AA	SEAL, DUST -----	1
6505-AB	RING, O -----	1
6505-AC	RING, BACK UP -----	1
6505-AD	RING, O -----	1
6505-AE	RING, BACK UP -----	1
6505-AF	PACKING, U -----	1
6505-AH	BUSHING -----	1
6505-AI	PLUG -----	1

(FS ) ( 4 )

G208

FIG. 6506 REAR LIFT CYLINDER

6506

FS

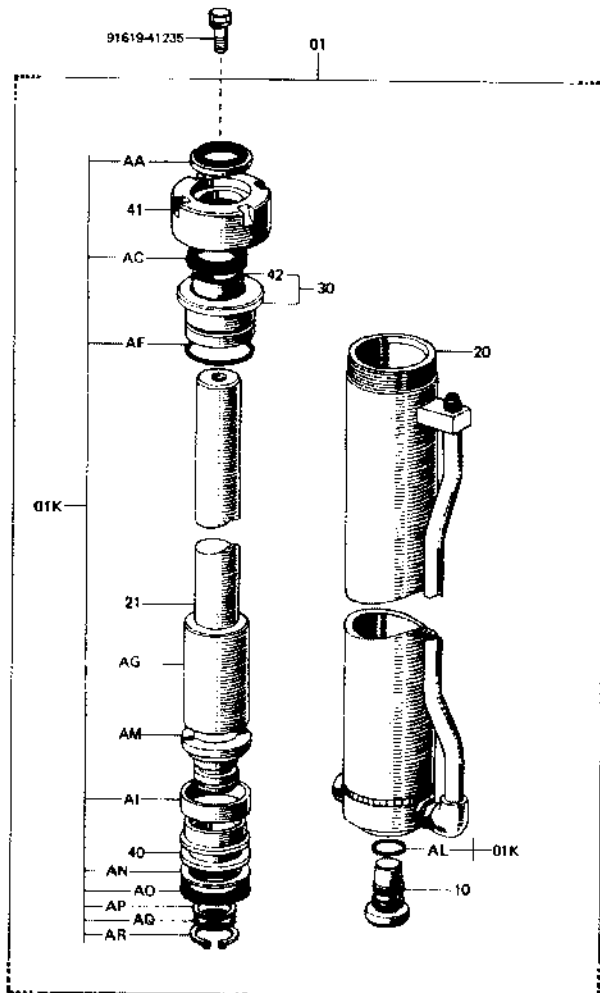

6506-002

PART NAME CODE	PART NAME	QTY
6506-01	CYLINDER ASSY, LIFT -----	1
6506-01K	CYLINDER O/H KIT, LIFT -----	1
6506-10	VALVE ASSY, FLOW REGULATOR -----	1
6506-20	CYLINDER SUB-ASSY, LIFT -----	1
6506-21	ROD SUB-ASSY, LIFT CYLINDER -----	1
6506-30	GUIDE SUB-ASSY, CYLINDER ROD -----	1
6506-40	PISTON, LIFT CYLINDER -----	1
6506-41	COVER, LIFT CYLINDER -----	1
6506-42	SLEEVE, LIFT CYLINDER ROD GUIDE -----	1
6506-AA	SEAL, DUST -----	1
6506-AC	PACKING, U -----	1
6506-AF	RING, O -----	1
6506-AG	SPACER, LIFT CYLINDER -----	1
6506-AI	RING, WEAR -----	1
6506-AL	RING, O -----	1
6506-AM	RING, STOPPER -----	1
6506-AN	RING, BACK UP -----	1
6506-AO	PACKING -----	1
6506-AP	RING, BACK UP -----	1
6506-AQ	RING, O -----	1
6506-AR	RING, SHAFT SNAP -----	1

(FS ) ( 5)

G208

FIG. 6511 TILT CYLINDER

6511

FS

FS

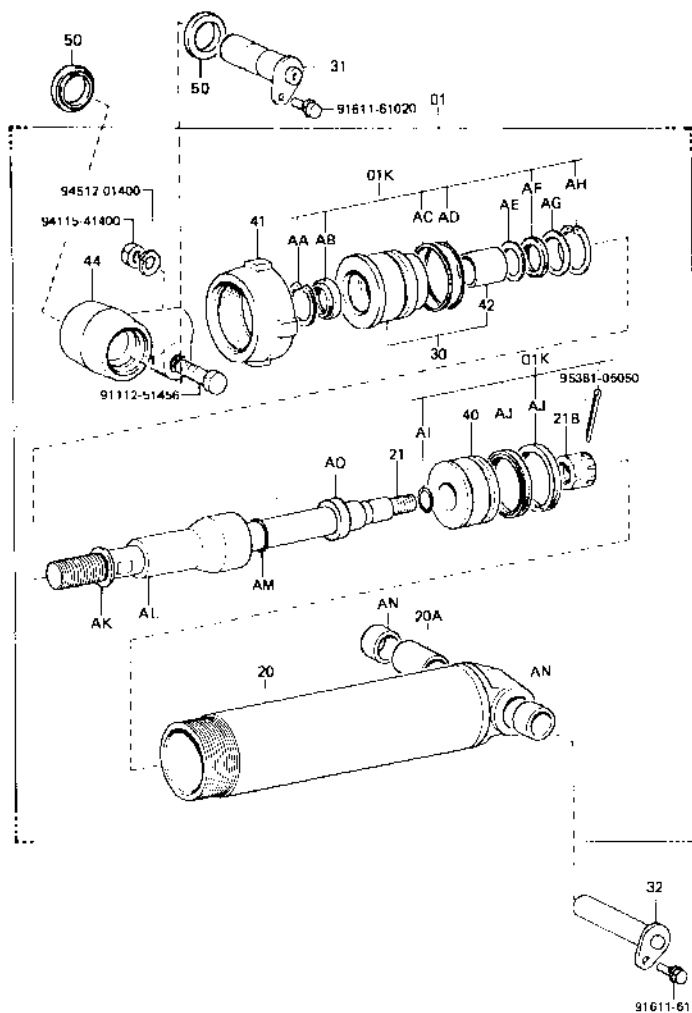

91611-61020

6511-01B

テイルト角度表  
TABLE OF TILT RANGE

生産期間 PROD DATE	型式 MODELS	タイヤ TIRE	揚 高 LIFTING HEIGHT	備 考 DESCRIPTION	テイルト角 TILT RANGE
8003-	F, FV, M, SV, V	SINGLE	H2000-H4000		6D - 12D
8003-	F, FV, M, SV, V	DOUBLE	H2000-H4500		6D - 12D
8003	F, FV, M, SV, V	SINGLE	H4500-H5000		6D - 8D
8003-	F, FV, M, SV, V	DOUBLE	H5000		6D 6D
8003-	F, FV, M, SV, V		H2000	FRONT GLASS	8D 10D
8003-	FSV, FS		H3700-H4700	DOMESTIC	8D - 6D
8003	FSV, FS		H5000-H6500	DOMESTIC	3D 6D
8003-	FSV, FS		H3700-H6500	EXPORT	6D - 6D
8003-	F, FV, M, SV, V	SINGLE	H2000-H4000	AUSTRALIA	3D 12D
8003-	F, FV, M, SV, V	DOUBLE	H2000-H4500	AUSTRALIA	3D - 12D
8003-	F, FV, M, SV, V	SINGLE	H4500 H5000	AUSTRALIA	3D - 8D
8003-	F, FV, M, SV, V	DOUBLE	H5000	AUSTRALIA	3D 6D
8003-	F, FV, M, SV, V		H2000	FRONT GLASS AUSTRALIA	3D - 6D
8003-	FV, M, SV, V		H3700-H6500	AUSTHALIA	3D 8D

6511-01B

FIG. 6511 TILT CYLINDER

# 6511

FS

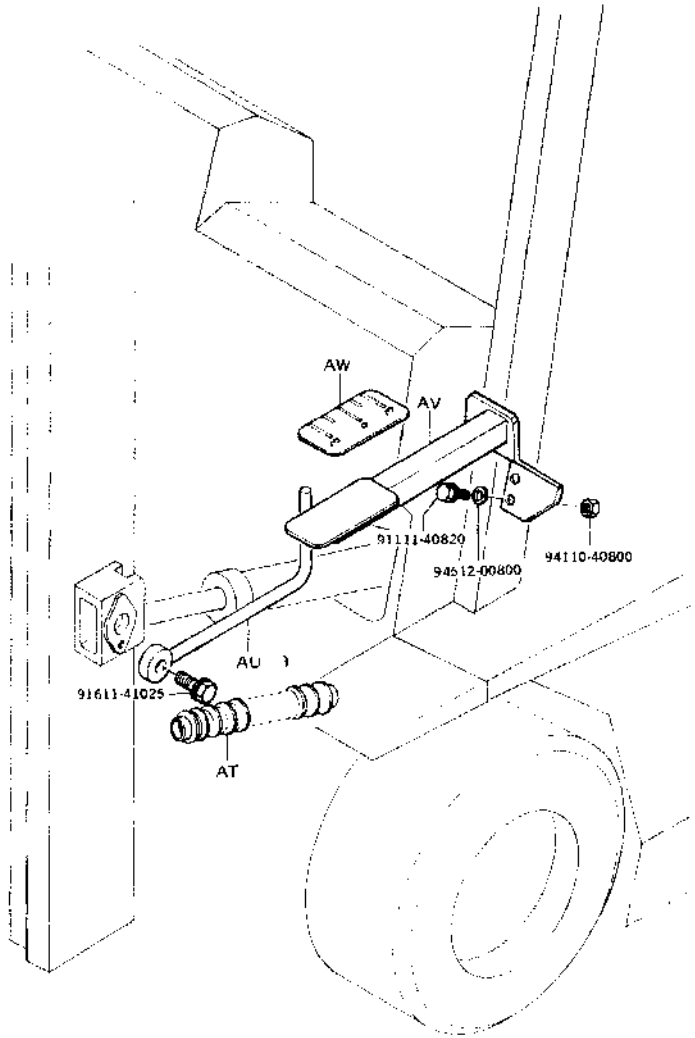

PART NAME CODE	PART NAME	QTY
6511-01K	CYLINDER O/H KIT, TILT	2
6511-20	CYLINDER SUB-ASSY, TILT	2
6511-20A	BUSH, PIN (FOR CYLINDER)	2
6511-21	ROD SUB-ASSY, TILT CYLINDER PISTON	2
6511-21B	NUT, CASTLE	2
6511-30	GUIDE SUB-ASSY, TILT CYLINDER ROD	2
6511-31	PIN SUB-ASSY, TILT CYLINDER, FR	2
6511-32	PIN SUB-ASSY, TILT CYLINDER, RR	2
6511-40	PISTON, TILT CYLINDER	2
6511-41	COVER, TILT CYLINDER	2
6511-42	SLEEVE, TILT CYLINDER ROD GUIDE	2
6511-44	JOINT, PISTON ROD	2
6511-50	SEAL, GREASE	4
6511-AA	RING, HOLE SNAP	2
6511-AB	SEAL, DUST	2
6511-AC	RING, BACK UP	2
6511-AD	RING, O	2
6511-AE	RING, BACK UP	2
6511-AF	PACKING, U	2
6511-AG	PLATE, STOPPER	2
6511-AH	RING, HOLE SNAP	2
6511-AI	RING, O	2
6511-AJ	PACKING, U	4
6511-AK	SHIM, TILT CONTROL	99
6511-AL	SPACER, TILT CONTROL	2
6511-AM	RING, O	4
6511-AN	COLLAR	4
6511-AO	SPACER, TILT CONTROL	2
6511-AT	BOOT SUB-ASSY	2
6511-AU	OAR SUB-ASSY, TILT GAUGE	1
6511-AV	BRACKET SUB-ASSY, TILT GAUGE	1
6511-AW	PLATE, TILT CYLINDER INDICATOR	1

FIG. 6701 OIL PUMP

**6701**

FS

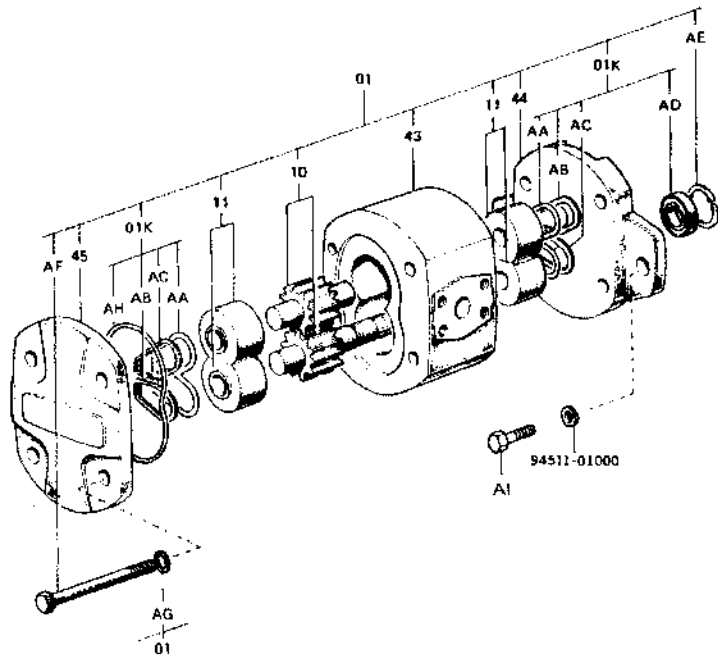

6701 01K

PART NAME CODE	PART NAME	QTY
6701-01	PUMP ASSY, OIL -----	1
6701-01K	PUMP O/H KIT, OIL -----	1
6701-10	GEAR SET -----	1
6701-11	BUSH SET, NO.1 -----	2
6701-43	BODY -----	1
6701-44	FLANGE, MOUNTING -----	1
6701-45	COVER -----	1
6701-AA	SEAL, BUSHING -----	2
6701-AB	RING, BACKING, RH -----	2
6701-AC	RING, BACKING, LH -----	2
6701-AD	SEAL, OIL -----	1
6701-AE	RING, SNAP -----	1
6701-AF	BOLT -----	4
6701-AG	WASHER, SPRING -----	4
6701-AH	SEAL, BODY -----	2
6701-AI	BOLT -----	2

(FS) ( 7)

G208



FIG. 6705 OIL CONTROL VALVE

# 6705

FS

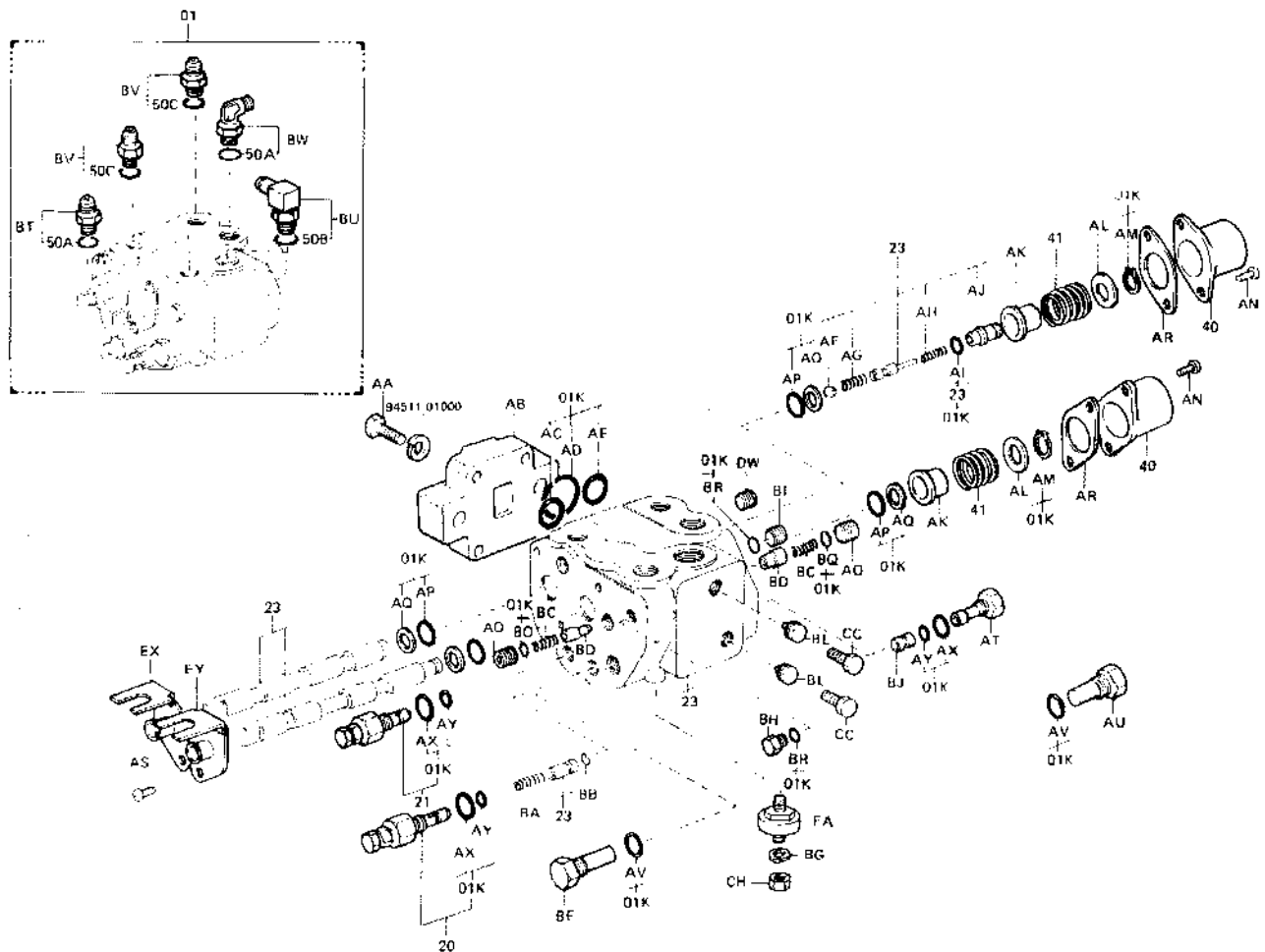





FIG. 6705 OIL CONTROL VALVE

6705

FS (3-WAY)

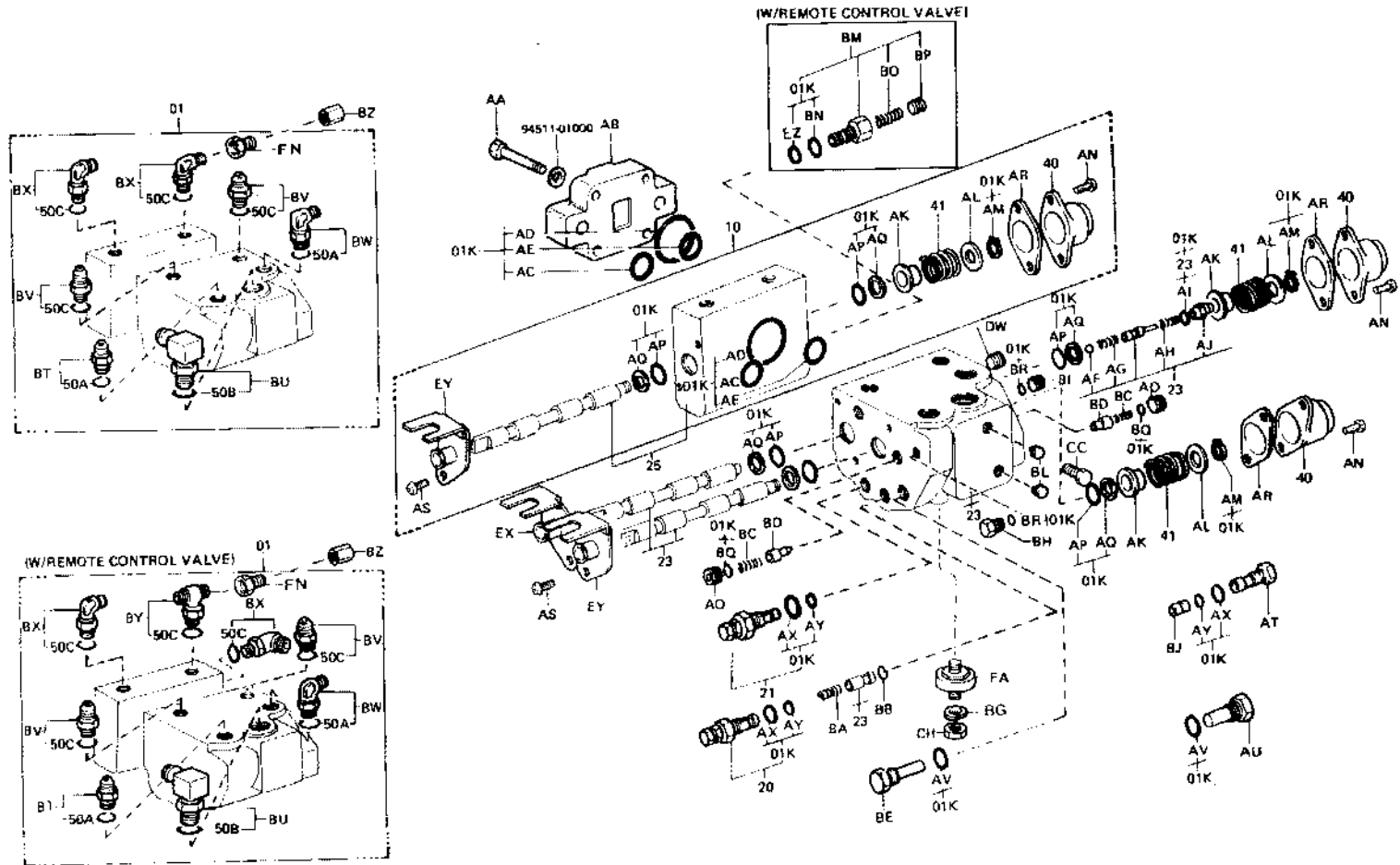
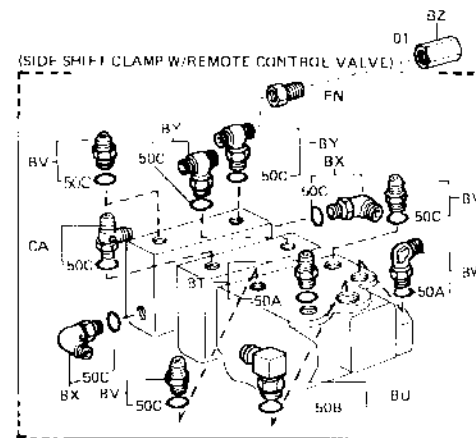
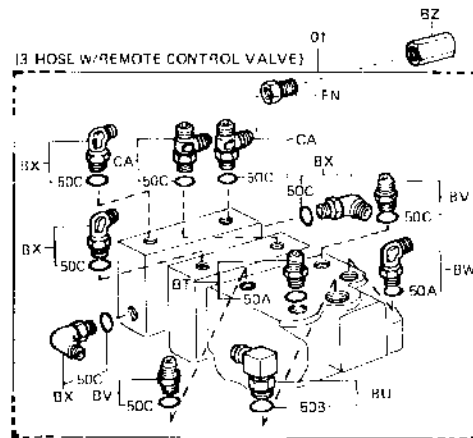
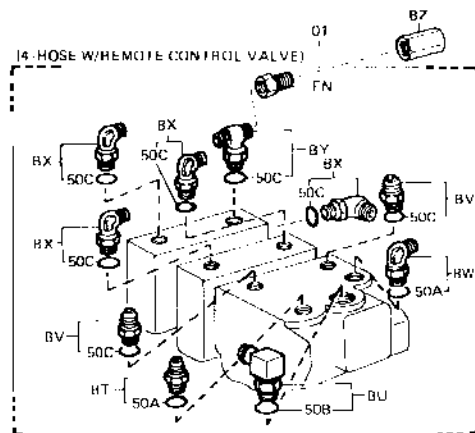
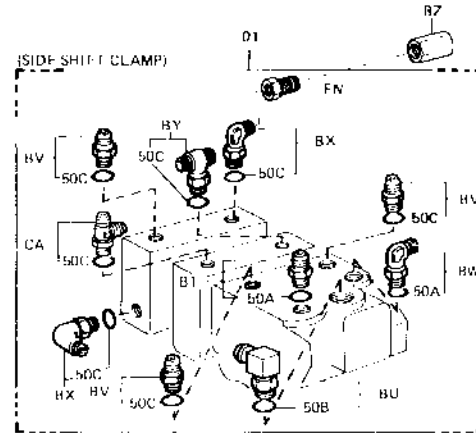
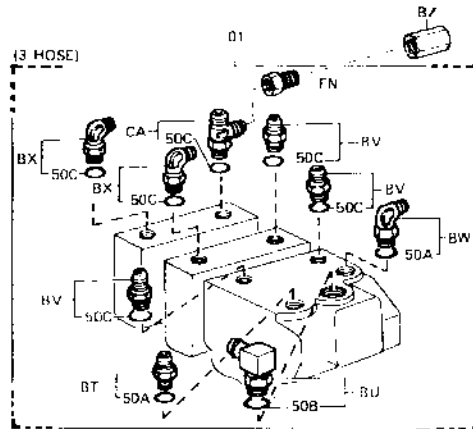
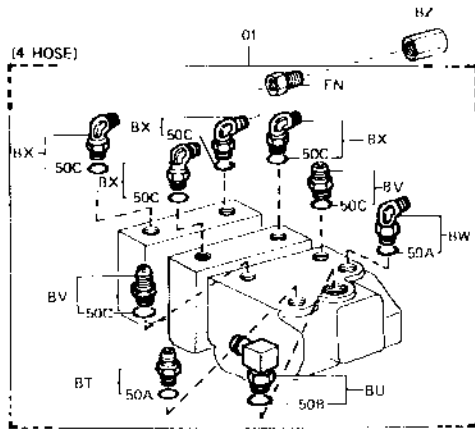

FIG. 6705 OIL CONTROL VALVE

6705

FS (4-WAY)



6705 D58



FIG. 6705 OIL CONTROL VALVE

6705

FS (4-WAY..UL)

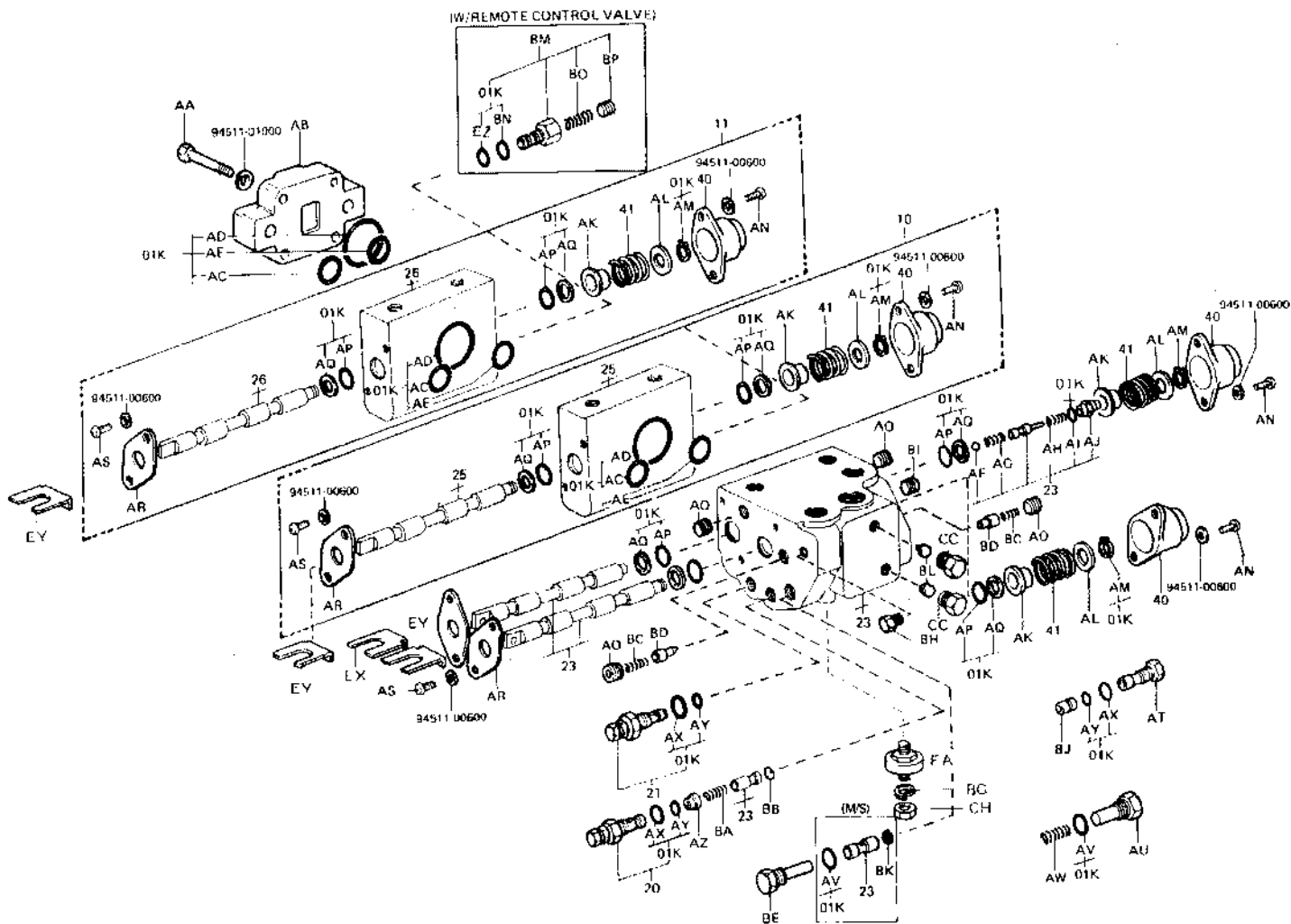
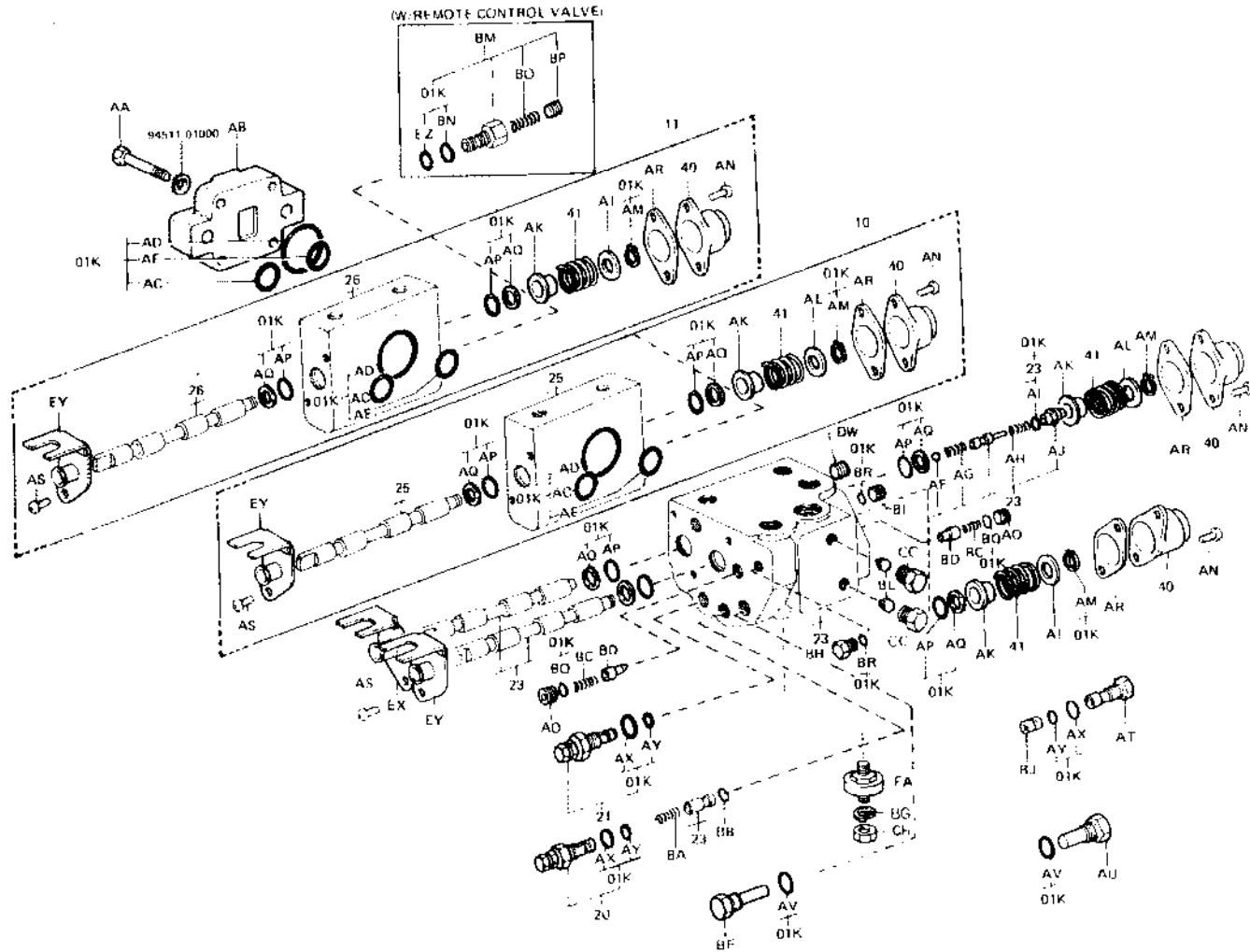

FIG. 6705 OIL CONTROL VALVE

6705

FS (4-WAY)



# 6705

PART NAME CODE	PART NAME	QTY
6705-01	VALVE ASSY, OIL CONTROL -----	1
6705-01K	VALVE O/H KIT, OIL CONTROL -----	1
6705-10	VALVE ASSY, PLUNGER SECTION, NO.1 -----	1
6705-11	VALVE ASSY, PLUNGER SECTION, NO.2 -----	1
6705-20	VALVE SET, PILOT RELIEF, NO.1 -----	1
6705-21	VALVE SET, PILOT RELIEF, NO.2 -----	1
6705-23	HOUSING & SPOOL SET, NO.1 -----	1
6705-25	HOUSING & SPOOL SET, ATTACHMENT, NO.1 -----	1
6705-26	HOUSING & SPOOL SET, ATTACHMENT, NO.2 -----	1
6705-40	COVER, SPRING -----	2
6705-41	SPRING, COMPRESSION (FOR SPOOL RETURN) -----	2
6705-50A	RING, O, NO.1 (FOR VALVE FITTING) -----	2
6705-50B	RING, O, NO.2 (FOR VALVE FITTING) -----	1
6705-50C	RING, O, NO.3 (FOR VALVE FITTING) -----	2
6705-AA	BOLT -----	4
6705-AB	HOUSING, OUTLET -----	1
6705-AC	RING, O -----	1
6705-AD	RING, O -----	1
6705-AE	RING, O -----	1
6705-AF	BALL, STEEL -----	1
6705-AG	SPRING -----	1
6705-AH	SPRING, COMPRESSION -----	1
6705-AI	RING, O -----	1
6705-AJ	STOPPER -----	1
6705-AK	HOLDER, SPRING -----	2
6705-AL	WASHER, PLATE -----	2
6705-AM	RING, SHAFT SNAP -----	2
6705-AN	SCREW -----	4
6705-AO	PLUG -----	2
6705-AP	RING, O -----	4
6705-AQ	RING, BACK UP -----	4
6705-AR	HOLDER, SEAL -----	2
6705-AS	SCREW -----	4
6705-AT	STOPPER -----	1
6705-AU	STOPPER -----	1
6705-AV	RING, O -----	2
6705-AW	SPRING, COMPRESSION -----	1
6705-AX	RING, O -----	3
6705-AY	RING, O -----	3
6705-AZ	COLLAR -----	1
6705-BA	SPRING, COMPRESSION -----	1
6705-BB	WIRE, ORIFICE TURNING -----	1
6705-BC	SPRING, COMPRESSION -----	2
6705-BD	PLUNGER, CHECK -----	2
6705-BE	STOPPER -----	1
6705-BG	WASHER -----	4
6705-BH	PLUG -----	1
6705-BI	PLUG -----	1
6705-BJ	SEAT, VALVE -----	1
6705-BK	VALVE, CHECK -----	1
6705-BL	SEAT, INSERT -----	2
6705-BM	VALVE SUB-ASSY, RELIEF -----	1
6705-BN	RING, O -----	1

(FS) ( 8) G208

PART NAME CODE	PART NAME	QTY
6705-B0	SPRING -----	1
6705-BP	STOPPER -----	1
6705-BQ	RING, O -----	2
6705-BR	RING, O -----	2
6705-BT	FITTING -----	1
6705-BU	FITTING -----	1
6705-BV	FITTING -----	2
6705-BW	FITTING -----	1
6705-BX	FITTING -----	2
6705-BY	FITTING -----	1
6705-BZ	PLUG -----	2
6705-CA	FITTING -----	1
6705-CC	PLUG -----	2
6705-CH	NUT -----	4
6705-DW	PLUG -----	1
6705-EX	BRACKET SUB-ASSY, TILT -----	1
6705-EY	BRACKET SUB-ASSY, LIFT -----	1
6705-EZ	RING, O -----	1
6705-FA	INSULATOR -----	4
6705-FN	FITTING -----	2

(FS) ( 9) G208

FIG. 6709 OIL CONTROL VALVE LINK

6709

FS

FS (3-WAY)

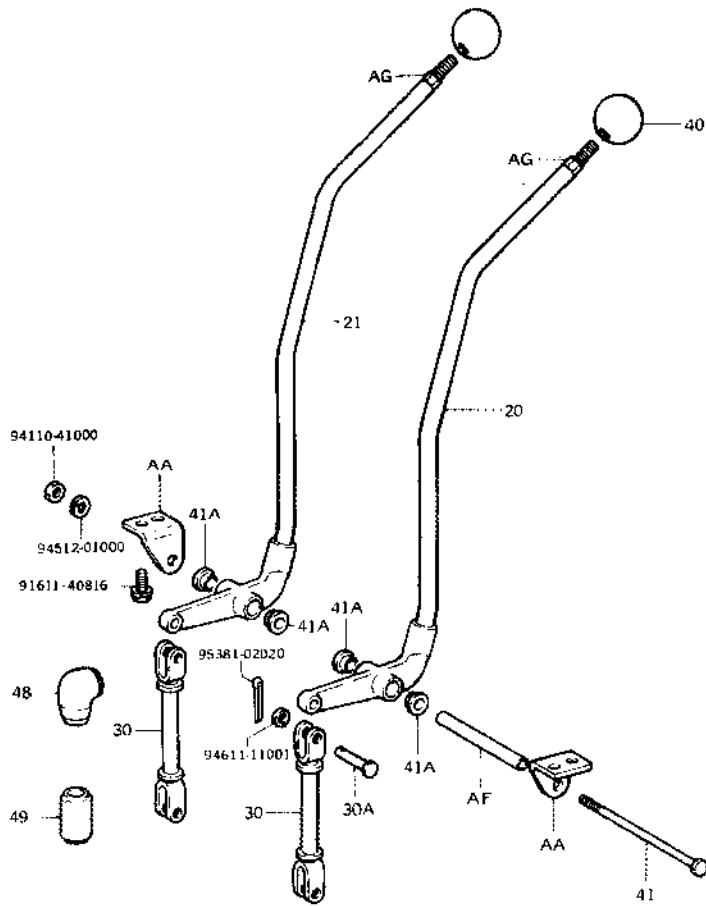

6709 016

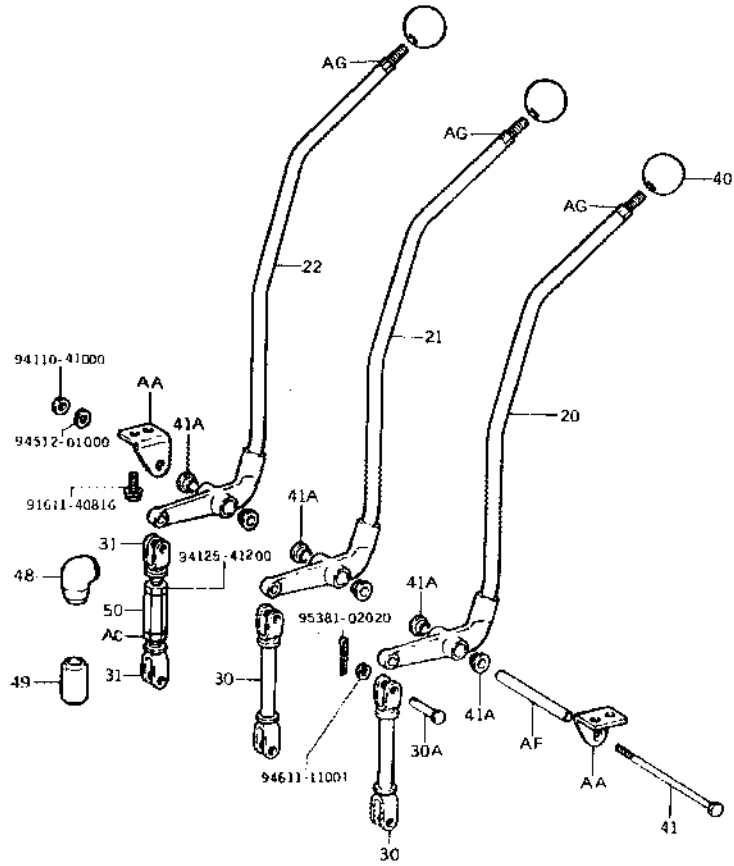

6709-017

FIG. 6709 OIL CONTROL VALVE LINK

**6709**

FS (4-WAY)

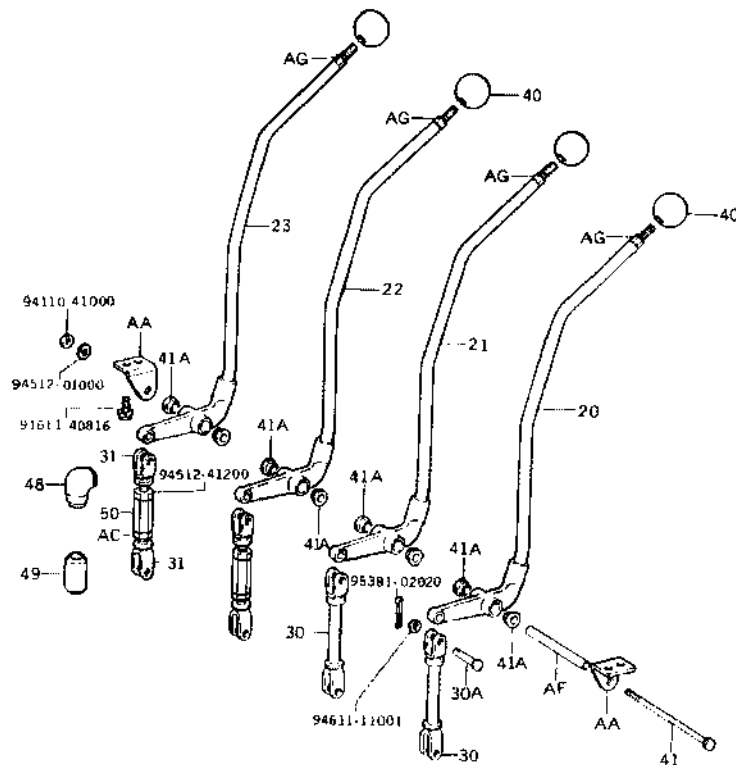

6709-01B

PART NAME CODE	PART NAME	QTY
6709-20	LEVER SUB-ASSY, CONTROL VALVE, NO.1	1
6709-21	LEVER SUB-ASSY, CONTROL VALVE, NO.2	1
6709-22	LEVER SUB-ASSY, CONTROL VALVE, NO.3	1
6709-23	LEVER SUB-ASSY, CONTROL VALVE, NO.4	1
6709-30	ROD SUB-ASSY, CONTROL VALVE LEVER, NO.1	1
6709-30A	PIN (FOR CONTROL VALVE LEVER ROD)	4
6709-31	ROD SUB-ASSY, CONTROL VALVE LEVER, NO.2	1
6709-40	KNUB, OIL CONTROL VALVE LEVER	2
6709-41	PIN, OIL CONTROL VALVE LEVER	1
6709-41A	BUSH (FOR LEVER PIN)	4
6709-48	BOOT, CONTROL VALVE LINK, NO.1	2
6709-49	BOOT, CONTROL VALVE LINK, NO.2	2
6709-50	TURNBUCKLE	1
6709-AA	BRACKET SUB-ASSY	1
6709-AC	NUT	1
6709-AF	SPACER	1
6709-AG	BOLT, STUD	2

FIG. 6801 BODY PIPING

6801

FS

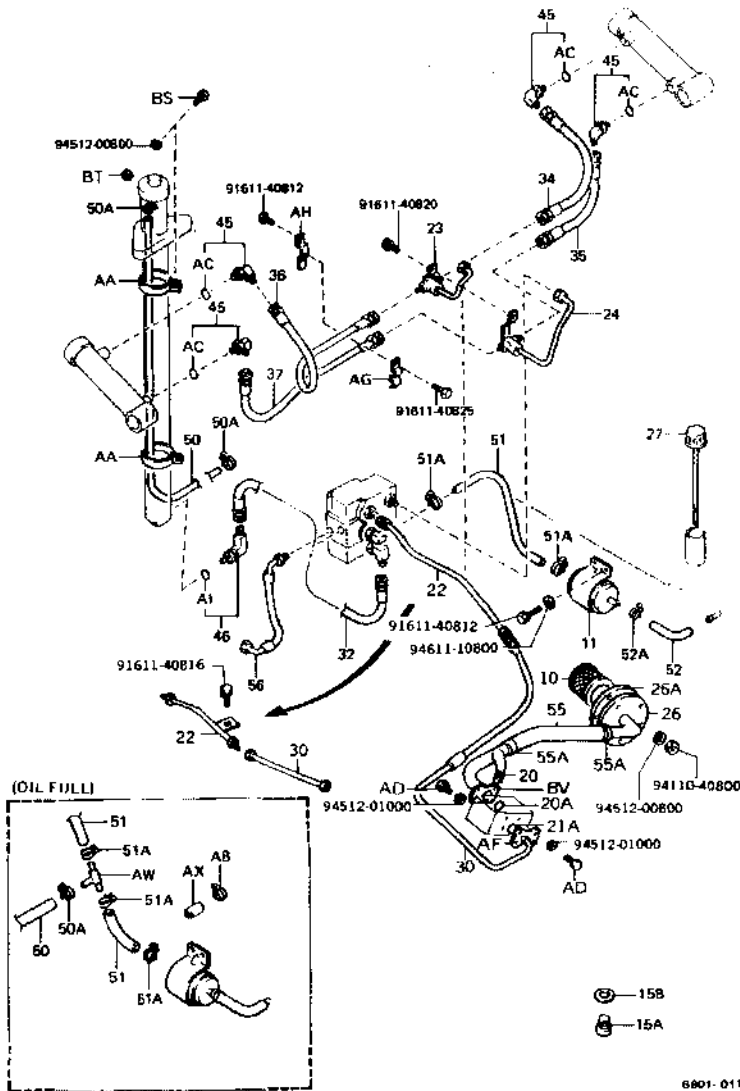

PART NAME CODE	PART NAME	QTY
6801-10	FILTER ASSY, SUCTION	1
6801-11	FILTER ASSY, RETURN	1
6801-15A	PLUG (FOR OIL TANK DRAIN)	1
6801-15B	GASKET (FOR OIL TANK DRAIN PLUG)	1
6801-20	PIPE SUB-ASSY (PUMP INLET)	1
6801-20A	RING, O (FOR OIL PUMP INLET)	1
6801-21A	RING, O (FOR OIL PUMP OUTLET)	1
6801-22	PIPE SUB-ASSY (PUMP TO VALVE)	1
6801-23	PIPE SUB-ASSY (TILT CYLINDER FRONT)	1
6801-24	PIPE SUB-ASSY (TILT CYLINDER REAR)	1
6801-26	OUTLET SUB-ASSY, OIL TANK	1
6801-26A	PACKING, OIL TANK COVER	1
6801-27	CAP SUB-ASSY, OIL TANK	1
6801-30	HOSE, HIGH PRESSURE, NO.1 (PUMP TO VALVE)	1
6801-32	HOSE, HIGH PRESSURE, NO.1 (VALVE TO LIFT)	1
6801-34	HOSE, HIGH PRESSURE, NO.1 (TILT FRONT)	1
6801-35	HOSE, HIGH PRESSURE, NO.1 (TILT REAR)	1
6801-36	HOSE, HIGH PRESSURE, NO.2 (TILT FRONT)	1
6801-37	HOSE, HIGH PRESSURE, NO.2 (TILT REAR)	1
6801-45	FITTING (FOR TILT CYLINDER)	2
6801-46	FITTING (FOR LIFT CYLINDER)	1
6801-50	HOSE, LOW PRESSURE, NO.1 (LIFT TO TANK)	1- 2
6801-50A	CLAMP (FOR LIFT TO TANK NO.1 HOSE)	2
6801-51	HOSE, LOW PRESSURE, NO.1 (VALVE TO TANK)	1
6801-51A	CLAMP (FOR VALVE TO TANK NO.1 HOSE)	2
6801-52	HOSE, LOW PRESSURE, NO.2 (VALVE TO TANK)	1
6801-52A	CLAMP (FOR VALVE TO TANK NO.2 HOSE)	2
6801-55	HOSE, LOW PRESSURE (TANK TO PUMP)	1
6801-55A	CLAMP (FOR TANK TO PUMP HOSE)	2
6801-56	HOSE, LOW PRESSURE (STEERING TO VALVE)	1
6801-AA	BAND, LIFT CYLINDER OVERFLOW HOSE	4
6801-AC	RING, O	4
6801-AD	BOLT	8
6801-AF	FLANGE, SPLIT	1
6801-AG	CLAMP	1
6801-AH	BRACKET SUB-ASSY, TILT HOSE	1
6801-AI	RING, O	1
6801-BS	BOLT	5
6801-BT	WASHER	5
68D1-BV	FLANGE	2



FIG. 6802 MAST PIPING

**6802**

FS

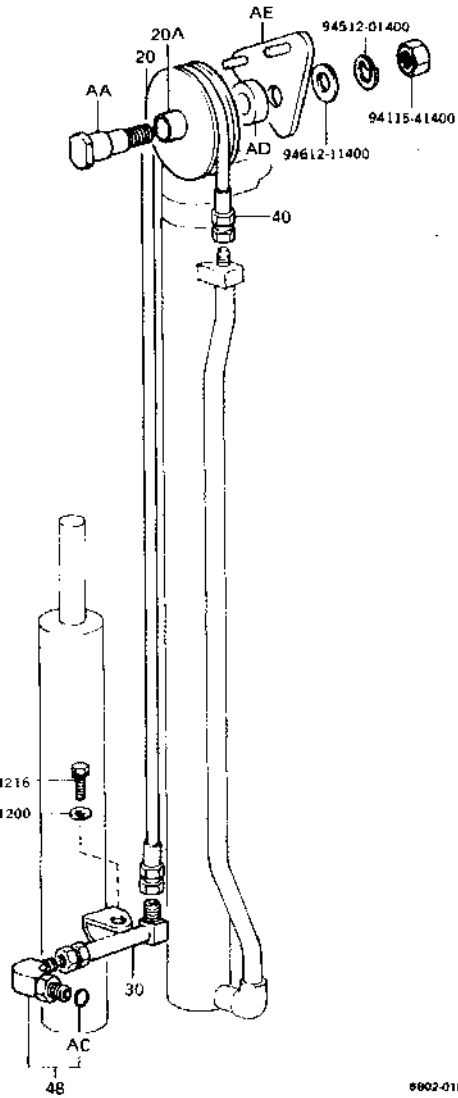

PART NAME CODE	PART NAME	QTY
6802-20	PULLEY SUB-ASSY, HOSE GUIDE, NO.1 -----	1
6802-30	PIPE SUB-ASSY, NO.1 (FRONT LIFT) -----	1
6802-40	HOSE, HIGH PRESSURE (FRONT LIFT PULLEY) -----	1
6802-48	FITTING (FOR FRONT LIFT CYLINDER) -----	1
6802-AA	PIN, HOSE GUIDE PULLEY -----	1
6802-AC	RING, O -----	1
6802-AD	COLLAR -----	1
6802-AE	STOPPER SUB-ASSY, HIGH PRESSURE HOSE -----	1

FIG. 6101 MAST

# 6101

FSV

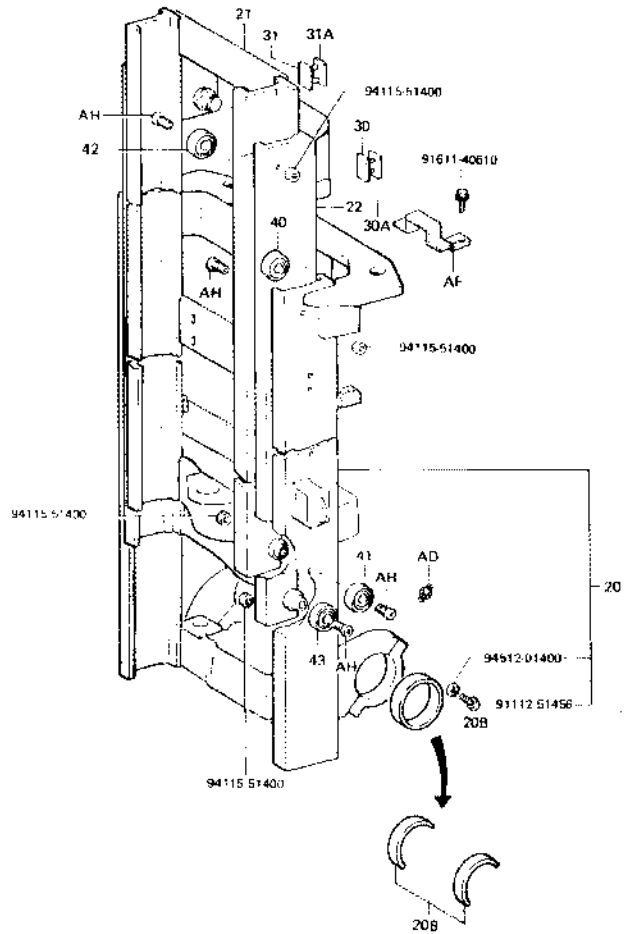

PART NAME CODE	PART NAME	QTY
6101-20	MAST SUB-ASSY, OUTER -----	1
6101-20B	BUSH, MAST SUPPORT -----	1
6101-21	MAST SUB-ASSY, INNER -----	1
6101-22	MAST SUB-ASSY, MIDDLE -----	1
6101-30	STRIP SUB-ASSY, OUTER MAST -----	2
6101-30A	SHIM, OUTER MAST STRIP -----	99
6101-31	STRIP SUB-ASSY, MIDDLE MAST -----	2
6101-31A	SHIM, MIDDLE MAST STRIP -----	99
6101-40	ROLLER, LIFT (FOR OUTER MAST) -----	2
6101-41	ROLLER, LIFT (FOR INNER MAST) -----	2
6101-42	ROLLER, LIFT (FOR MIDDLE MAST UPPER) -----	2
6101-43	ROLLER, LIFT (FOR MIDDLE MAST LOWER) -----	2
6101-AD	FITTING, GREASE -----	2
6101-AF	COVER, ROLLER -----	1
6101-AH	BOLT -----	8

( FSV ) ( 1 )

G208

FIG. 6301 LIFT BRACKET & FORK

6301

FSV

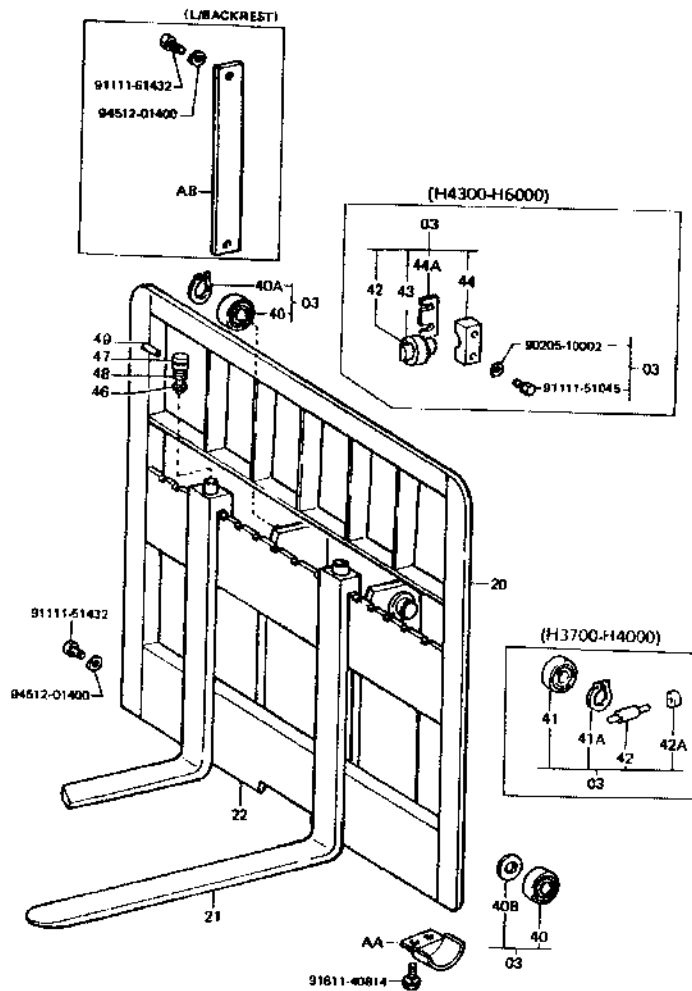

6301-063A

PART NAME CODE	PART NAME	QTY
6301-03	BRACKET ASSY, LIFT -----	1
6301-20	BACKREST SUB-ASSY -----	1
6301-21	FORK SUB-ASSY -----	2
6301-22	BRACKET SUB-ASSY, LIFT -----	1
6301-40	ROLLER, LIFT (UPPER, LOWER) -----	4
6301-40A	RING, SHAFT SNAP (UPPER, LOWER) -----	2
6301-40B	SHIM, LIFT ROLLER -----	99
6301-41	ROLLER, LIFT (CENTER) -----	2
6301-41A	RING, SHAFT SNAP (CENTER) -----	2
6301-42	ROLLER, SIDE -----	2
6301-42A	SHIM (FOR SIDE ROLLER) -----	99
6301-43	SHAFT, SIDE ROLLER -----	2
6301-44	HOLDER, SIDE ROLLER SHAFT -----	4
6301-44A	SHIM (FOR SHAFT HOLDER) -----	99
6301-46	PIN, FORK STOPPER -----	2
6301-47	KNOB, FORK STOPPER PIN -----	2
6301-48	SPRING, FORK STOPPER PIN -----	2
6301-49	PIN, SPRING (FOR FORK STOPPER PIN) -----	2
6301-AA	COVER, LIFT BRACKET ROLLER -----	4
6301-AB	PLATE, SIDE -----	2

(FSV ) ( 2 )

G208

FIG. 6302 CHAIN & CHAIN WHEEL

**6302**

FSV

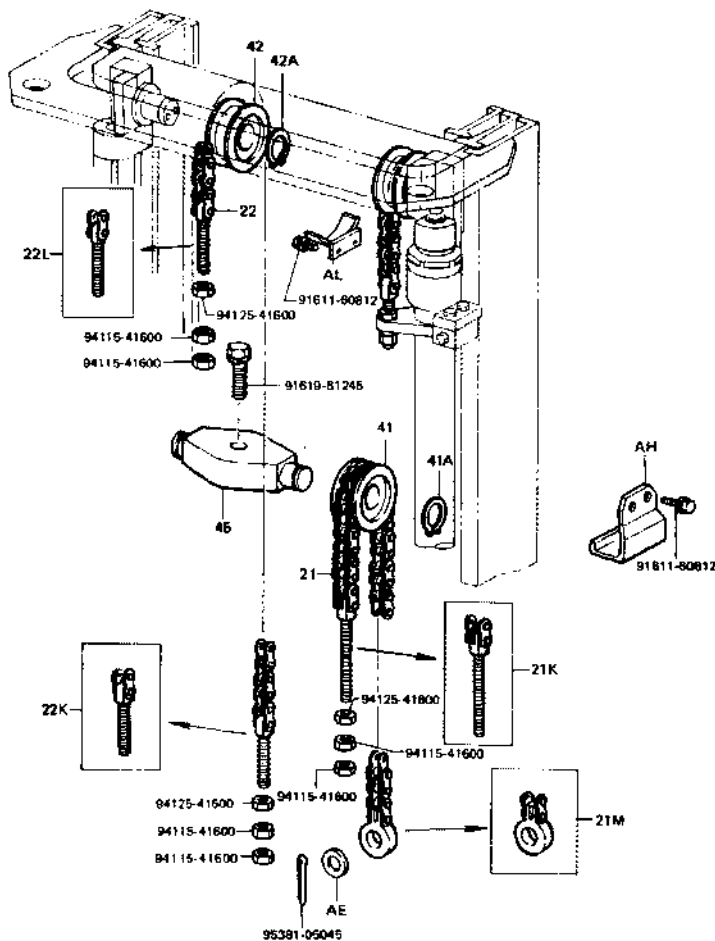

6302-003A

PART NAME CODE	PART NAME	QTY
6302-21	CHAIN SUB-ASSY (FRONT)	2
6302-21K	BOLT KIT, CHAIN ANCHDR, NO.1 (FRONT)	2
6302-21M	BOLT KIT, CHAIN EYE (FRONT)	2
6302-22	CHAIN SUB-ASSY (REAR)	2
6302-22K	BOLT KIT, CHAIN ANCHOR, NO.1 (REAR)	2
6302-22L	BOLT KIT, CHAIN ANCHOR, NO.2 (REAR)	2
6302-41	WHEEL, CHAIN (FRONT)	2
6302-41A	RING, SHAFT SNAP (FOR FRONT CHAIN WHEEL)	2
6302-42	WHEEL, CHAIN (REAR)	2
6302-42A	RING, SHAFT SNAP (FOR CHAIN WHEEL)	2
6302-45	SUPPORT, CHAIN WHEEL	1
6302-AE	WASHER, CHAIN SPECIAL	2
6302-AH	COVER, CHAIN WHEEL	2
6302-AL	COVER, CHAIN WHEEL	2

FIG. 6502 FRONT LIFT CYLINDER

**6502**

FSV

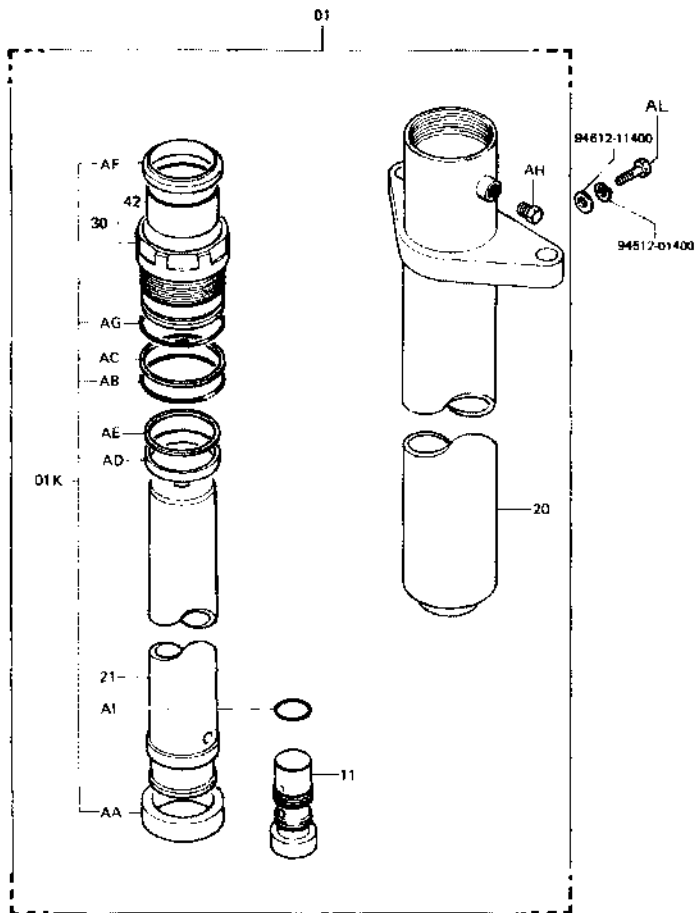

6502 001A

PART NAME CODE	PART NAME	QTY
6502-01	CYLINDER ASSY, LIFT -----	1
6502-01K	CYLINDER O/H KIT, LIFT -----	1
6502-11	VALVE ASSY, SAFETY DOWN -----	1
6502-20	CYLINDER SUB-ASSY, LIFT -----	1
6502-21	ROD SUB-ASSY, LIFT CYLINDER -----	1
6502-30	GUIDE SUB-ASSY, LIFT CYLINDER ROD -----	1
6502-42	SLEEVE, LIFT CYLINDER ROD GUIDE -----	1
6502-AA	BUSHING -----	1
6502-AB	RING, O -----	1
6502-AC	RING, BACK UP -----	1
6502-AD	PACKING, U -----	1
6502-AE	RING, BACK UP -----	1
6502-AF	SEAL, DUST -----	1
6502-AG	RING, U -----	1
6502-AH	PLUG -----	1
6502-AI	RING, O -----	1
6502-AL	BOLT -----	2

(FSV ) ( 4)

G208

FIG. 6503 REAR LIFT CYLINDER

**6503**

FSV

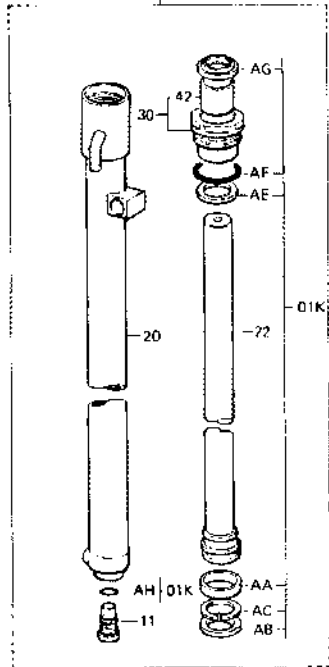
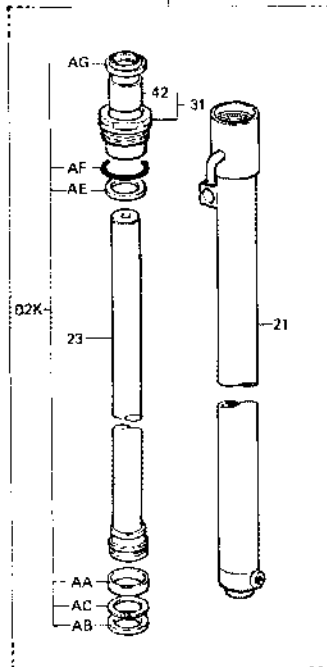
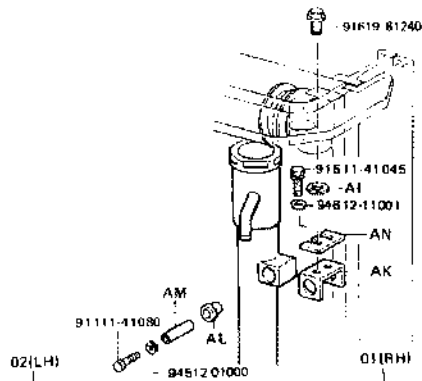

6503 001

PART NAME CODE	PART NAME	QTY
6503-01	CYLINDER ASSY, LIFT, RH	1
6503-01K	CYLINDER O/H KIT, LIFT, RH	1
6503-02	CYLINDER ASSY, LIFT, LH	1
6503-02K	CYLINDER O/H KIT, LIFT, LH	1
6503-11	VALVE ASSY, SAFETY DOWN	1
6503-20	CYLINDER SUB-ASSY, LIFT, RH	1
6503-21	CYLINDER SUB-ASSY, LIFT, LH	1
6503-22	ROD SUB-ASSY, LIFT CYLINDER, RH	1
6503-23	ROD SUB-ASSY, LIFT CYLINDER, LH	1
6503-30	GUIDE SUB-ASSY, LIFT CYLINDER ROD, RH	1
6503-31	GUIDE SUB-ASSY, LIFT CYLINDER ROD, LH	1
6503-42	SLEEVE, LIFT CYLINDER ROD GUIDE	2
6503-AA	RING, WEAR	2
6503-AB	PACKING, U	2
6503-AC	RING, BACK UP	2
6503-AE	PACKING, U	2
6503-AF	RING, O	2
6503-AG	SEAL, DUST	2
6503-AH	RING, O	1
6503-AI	SHIM	3
6503-AK	BRACKET SUB-ASSY, LIFT CYLINDER	2
6503-AL	BUSHING	4
6503-AM	SPACER	2
6503-AN	SHIM	6

FIG. 6511 TILT CYLINDER

6511

FSV

FSV

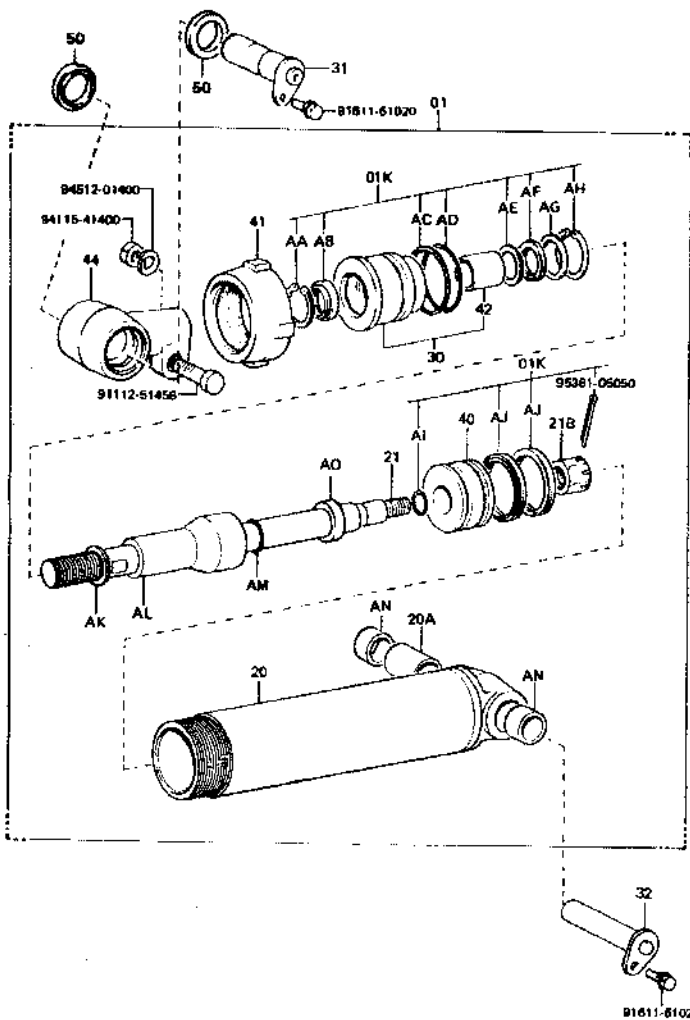

テイルト角度表  
TABLE OF TILT RANGE

生産期間 PROD DATE	型式 MODELS	タイヤ TIRE	高さ LIFTING HEIGHT	備考 DESCRIPTION	テイルト角 TILT RANGE
8003-	F, FV, M, SV, V	SINGLE	H2000-H4000		6D - 12D
8003-	F, FV, M, SV, V	DOUBLE	H2000-H4500		6D - 12D
8003-	F, FV, M, SV, V	SINGLE	H4500-H5000		6D - 6D
8003-	F, FV, M, SV, V	DOUBLE	H5000		6D - 6D
8003-	F, FV, M, SV, V		H2000	FRONT GLASS	6D - 10D
8003-	FSV, FS		H3700-H4700	DOMESTIC	8D - 8D
8003-	FSV, FS		H5000-H6500	DOMESTIC	3D - 6D
8003-	FSV, FS		H3700-H6500	EXPORT	6D - 6D
8003-	F, FV, M, SV, V	SINGLE	H2000-H4000	AUSTRALIA	3D - 12D
8003-	F, FV, M, SV, V	DOUBLE	H2000-H4500	AUSTRALIA	3D - 12D
8003-	F, FV, M, SV, V	SINGLE	H4500-H5000	AUSTRALIA	3D - 6D
8003-	F, FV, M, SV, V	DOUBLE	H5000	AUSTRALIA	3D - 6D
8003-	F, FV, M, SV, V		H2000	FRONT GLASS AUSTRALIA	3D - 6D
8003-	FV, M, SV, V		H3700-H6500	AUSTRALIA	3D - 6D

6511-018

6511-018

FIG. 6511 TILT CYLINDER

6511

FSV

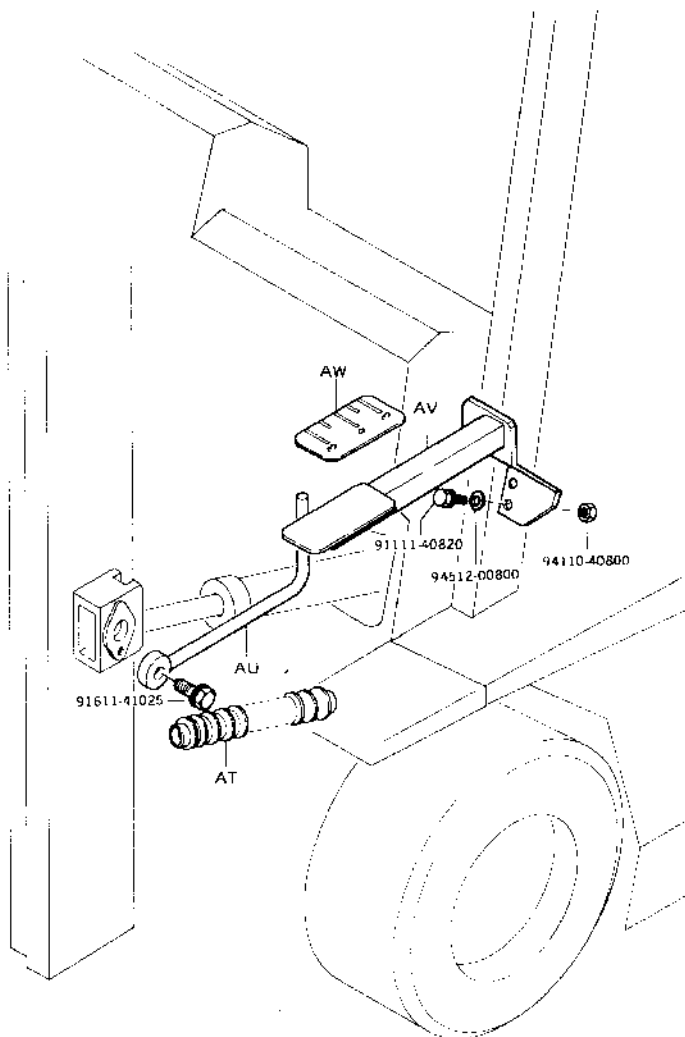

6511-013

PART NAME CODE	PART NAME	QTY
6511-01K	CYLINDER O/H KIT, TILT -----	2
6511-20	CYLINDER SUB-ASSY, TILT -----	2
6511-20A	BUSH, PIN (FOR CYLINDER) -----	2
6511-21	ROD SUB-ASSY, TILT CYLINDER PISTON -----	2
6511-21B	NUT, CASTLE -----	2
6511-30	GUIDE SUB-ASSY, TILT CYLINDER ROD -----	2
6511-31	PIN SUB-ASSY, TILT CYLINDER, FR -----	2
6511-32	PIN SUB-ASSY, TILT CYLINDER, RR -----	2
6511-40	PISTON, TILT CYLINDER -----	2
6511-41	COVER, TILT CYLINDER -----	2
6511-42	SLEEVE, TILT CYLINDER ROD GUIDE -----	2
6511-44	JOINT, PISTON ROD -----	2
6511-50	SEAL, GREASE -----	4
6511-AA	RING, HOLE SNAP -----	2
6511-AB	SEAL, OUST -----	2
6511-AC	RING, BACK UP -----	2
6511-AD	RING, O -----	2
6511-AE	RING, BACK UP -----	2
6511-AF	PACKING, U -----	2
6511-AG	PLATE, STOPPER -----	2
6511-AH	RING, HOLE SNAP -----	2
6511-AI	RING, O -----	2
6511-AJ	PACKING, U -----	4
6511-AK	SHIM, TILT CONTROL -----	99
6511-AL	SPACER, TILT CONTROL -----	2
6511-AM	RING, O -----	4
6511-AN	COLLAR -----	4
6511-AO	SPACER, TILT CONTROL -----	2
6511-AT	BOOT SUB-ASSY -----	2
6511-AU	BAR SUB-ASSY, TILT GAUGE -----	1
6511-AV	BRACKET SUB-ASSY, TILT GAUGE -----	1
6511-AW	PLATE, TILT CYLINDER INDICATOR -----	1

( FSV ) ( 6 )

G208



FIG. 6701 OIL PUMP

**6701**

FSV

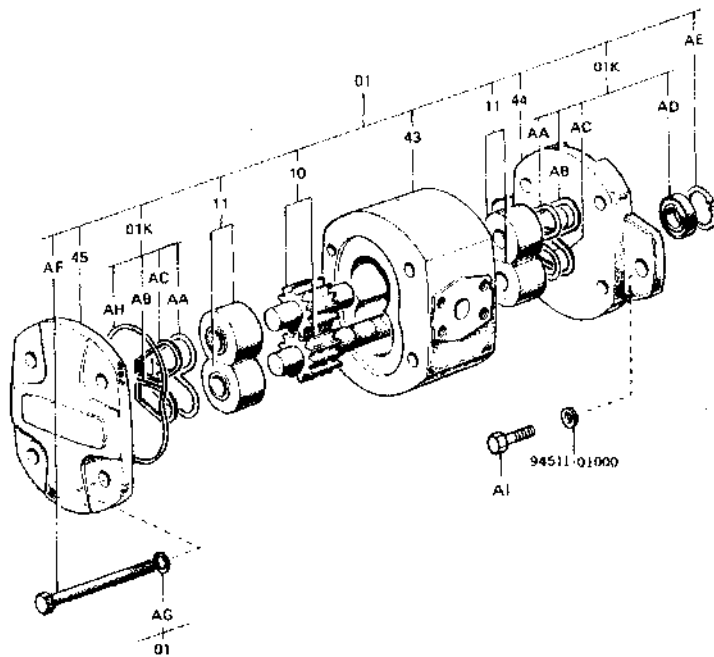

6701 018

PART NAME CODE	PART NAME	QTY
6701-01	PUMP ASSY, OIL -----	1
6701-01K	PUMP O/H KIT, OIL -----	1
6701-10	GEAR SET -----	1
6701-11	BUSH SET, NO.1 -----	2
6701-43	BODY -----	1
6701-44	FLANGE, MOUNTING -----	1
6701-45	COVER -----	1
6701-AA	SEAL, BUSHING -----	2
6701-AB	RING, BACKING, RH -----	2
6701-AC	RING, BACKING, LH -----	2
6701-AD	SEAL, OIL -----	1
6701-AE	RING, SNAP -----	1
6701-AF	BOLT -----	4
6701-AG	WASHER, SPRING -----	4
6701-AH	SEAL, BODY -----	2
6701-A1	BOLT -----	2

(FSV ) ( 7 )

G208

FIG. 6705 OIL CONTROL VALVE

6705

FSV (UL)

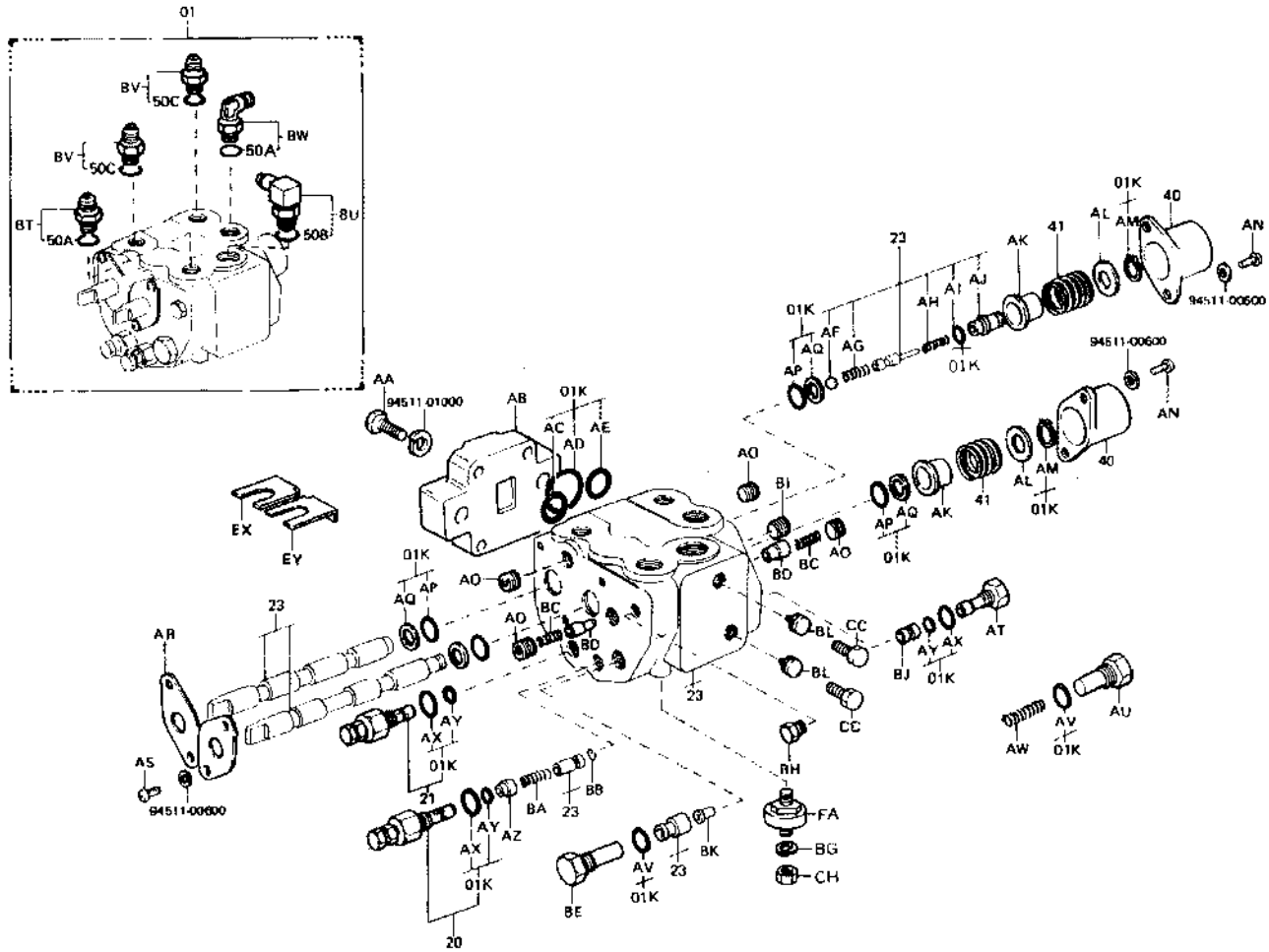

FIG. 6705 OIL CONTROL VALVE

# 6705

FSV

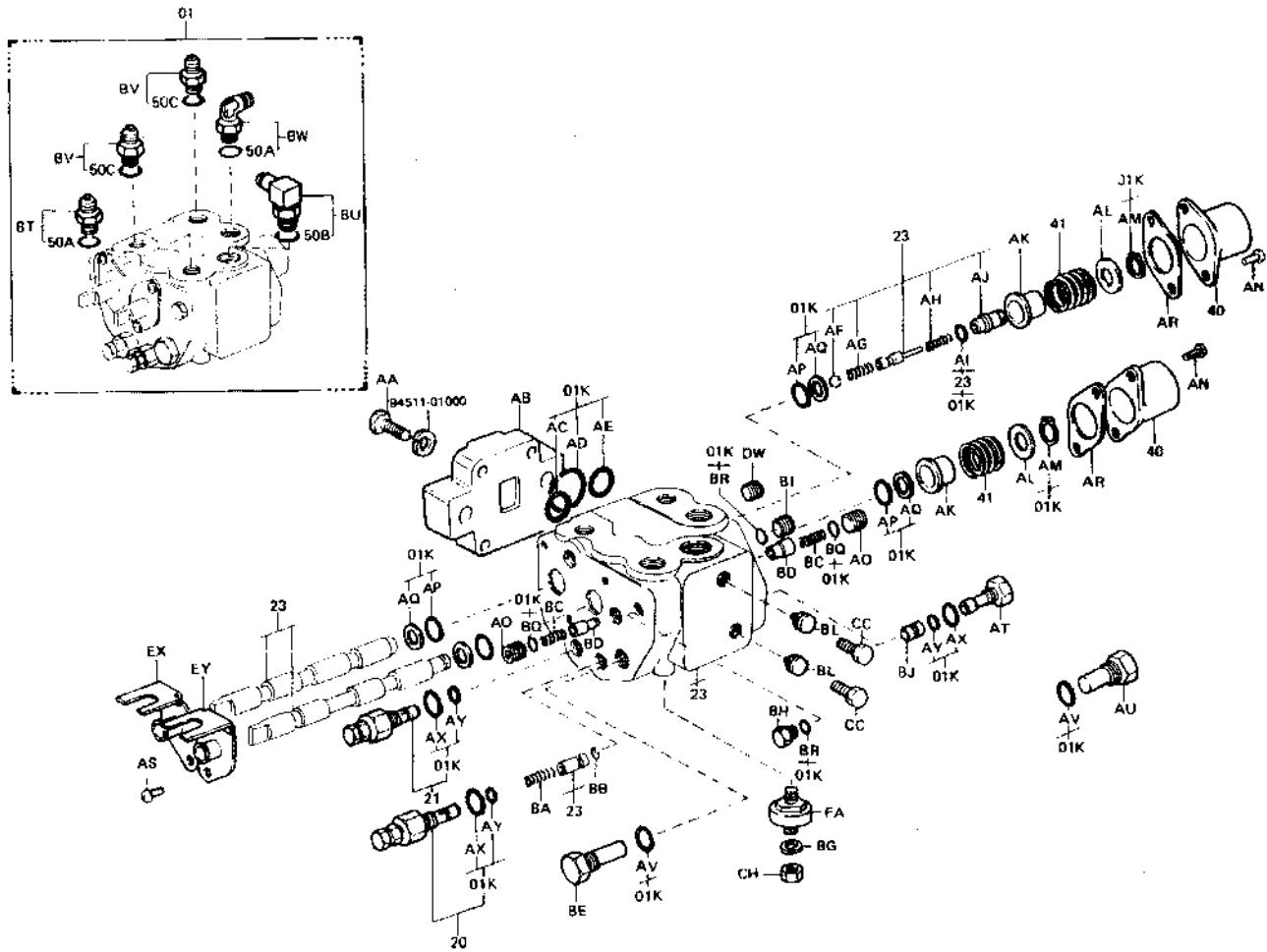

FIG. 6705 OIL CONTROL VALVE

6705

FSV (3-WAY..UL)

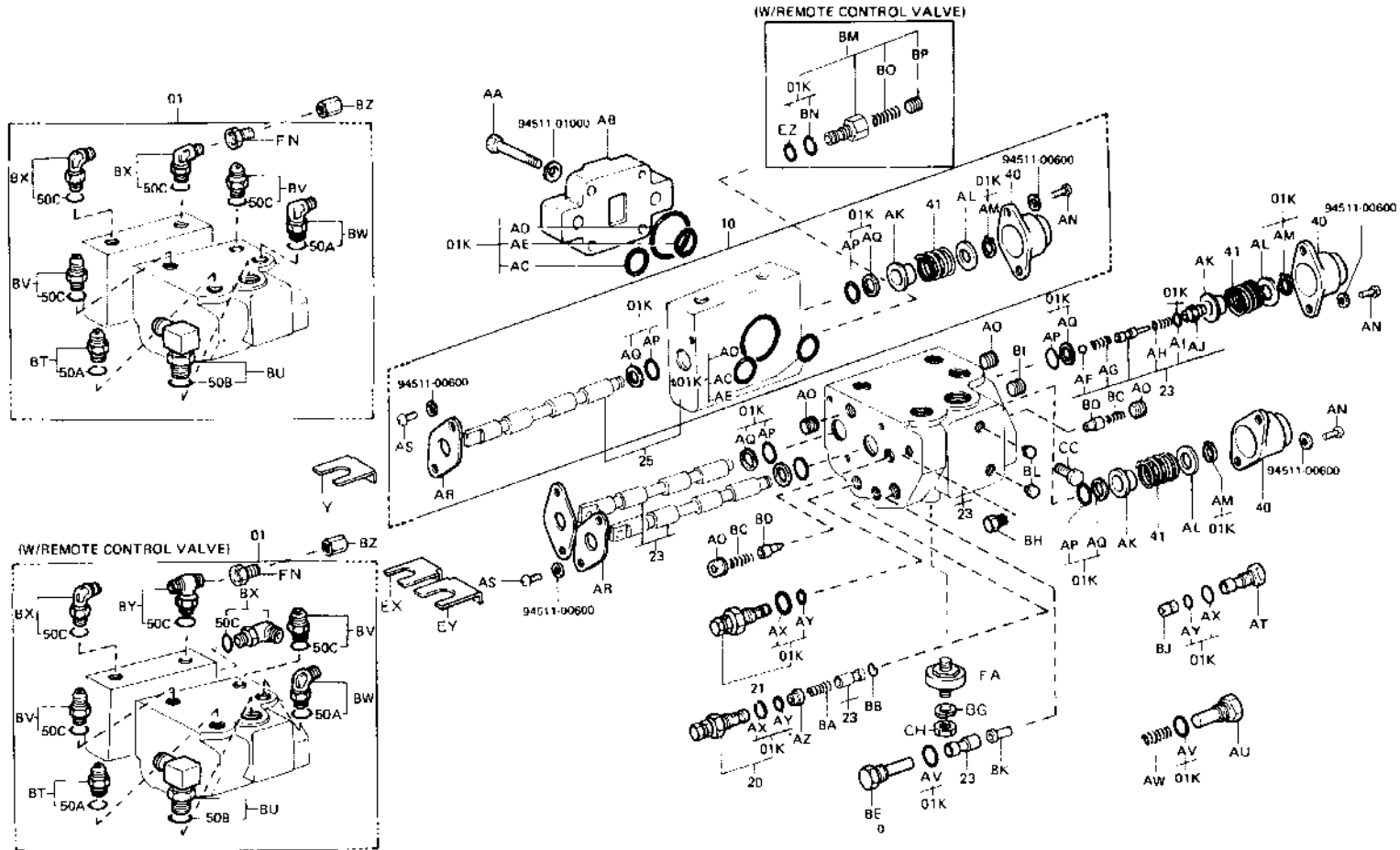

FIG. 6705 OIL CONTROL VALVE

# 6705

FSV (3-WAY)

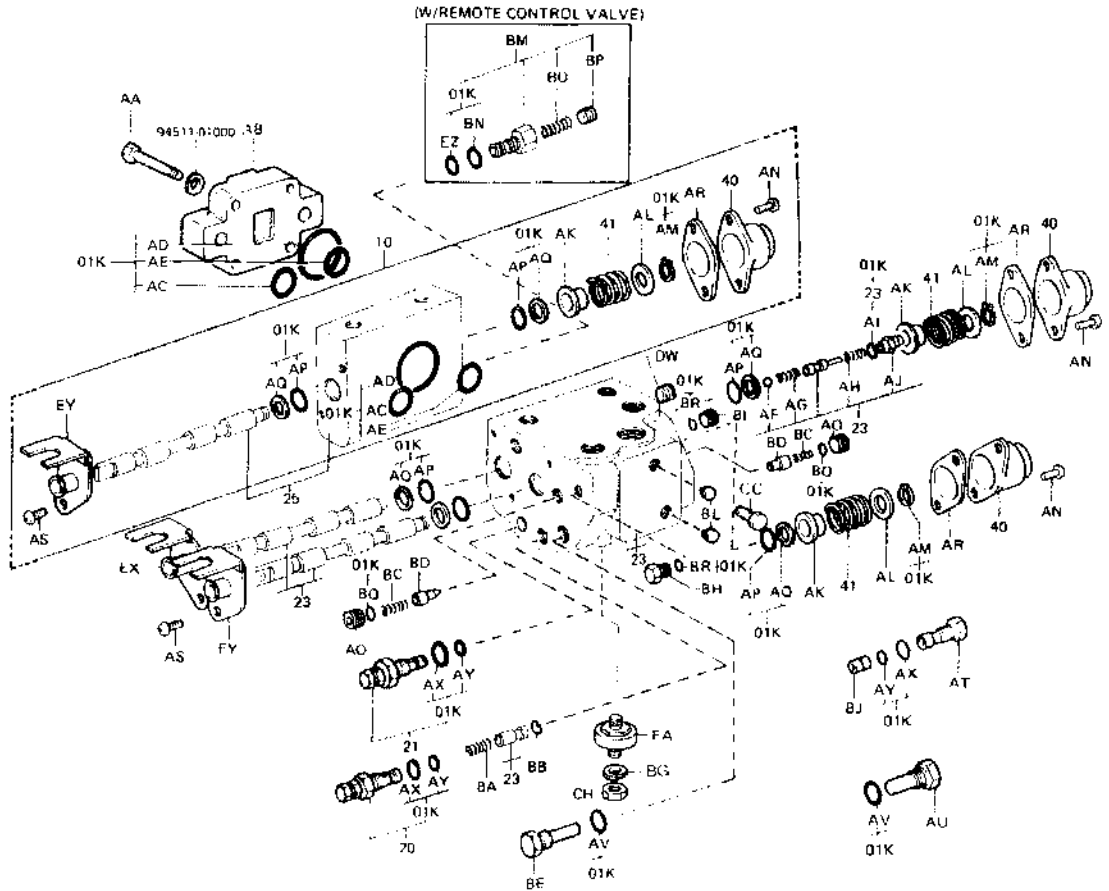
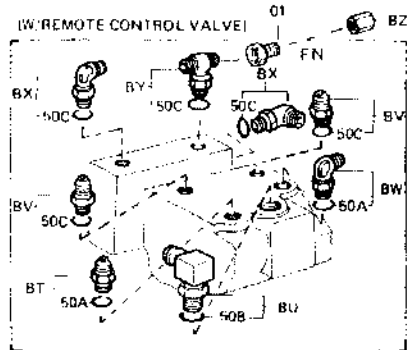
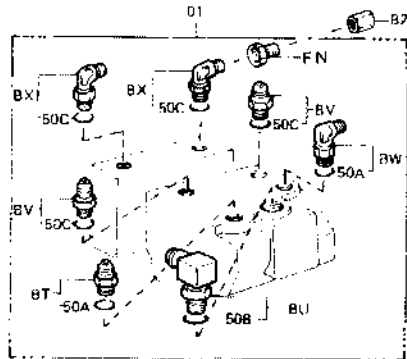
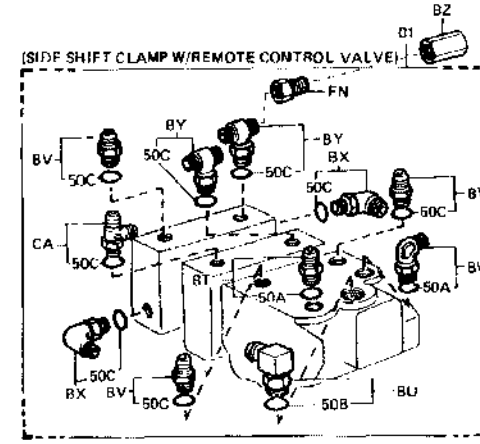
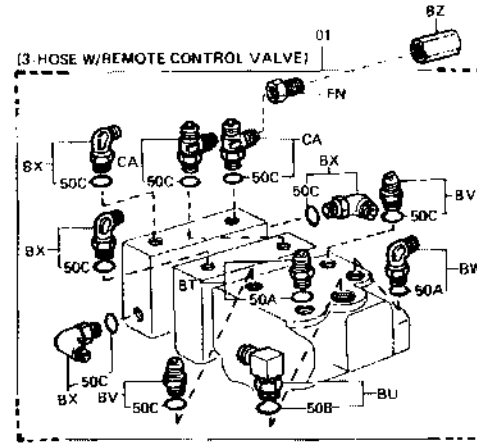
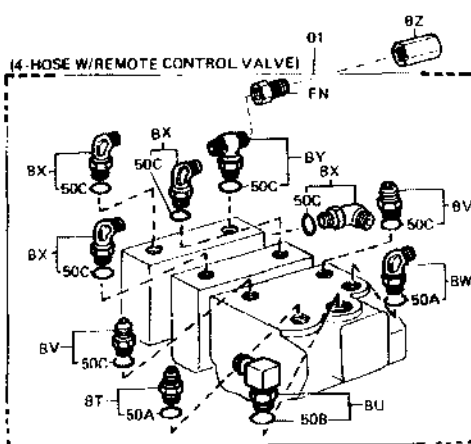
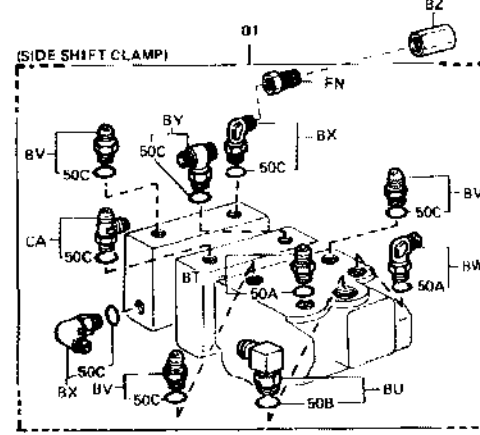
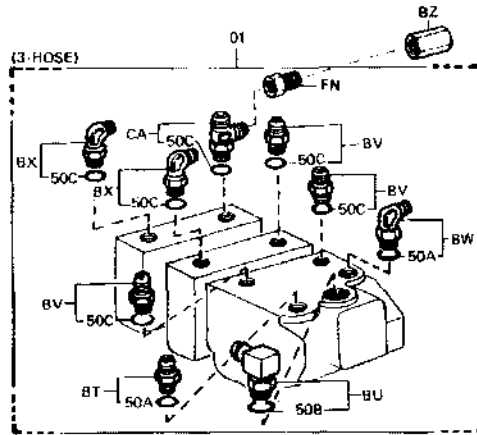
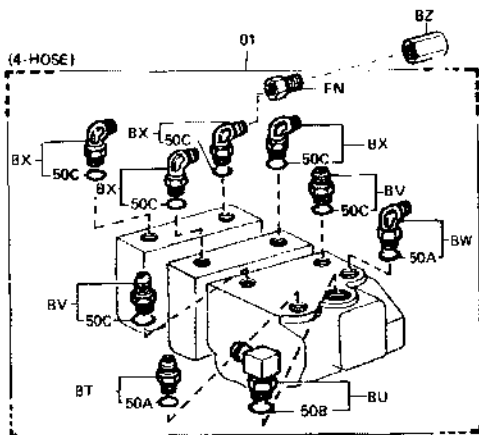

FIG. 6705 OIL CONTROL VALVE

6705

FSV (4-WAY)



6705-058



FIG. 6705 OIL CONTROL VALVE

6705

FSV (4-WAY..UL)

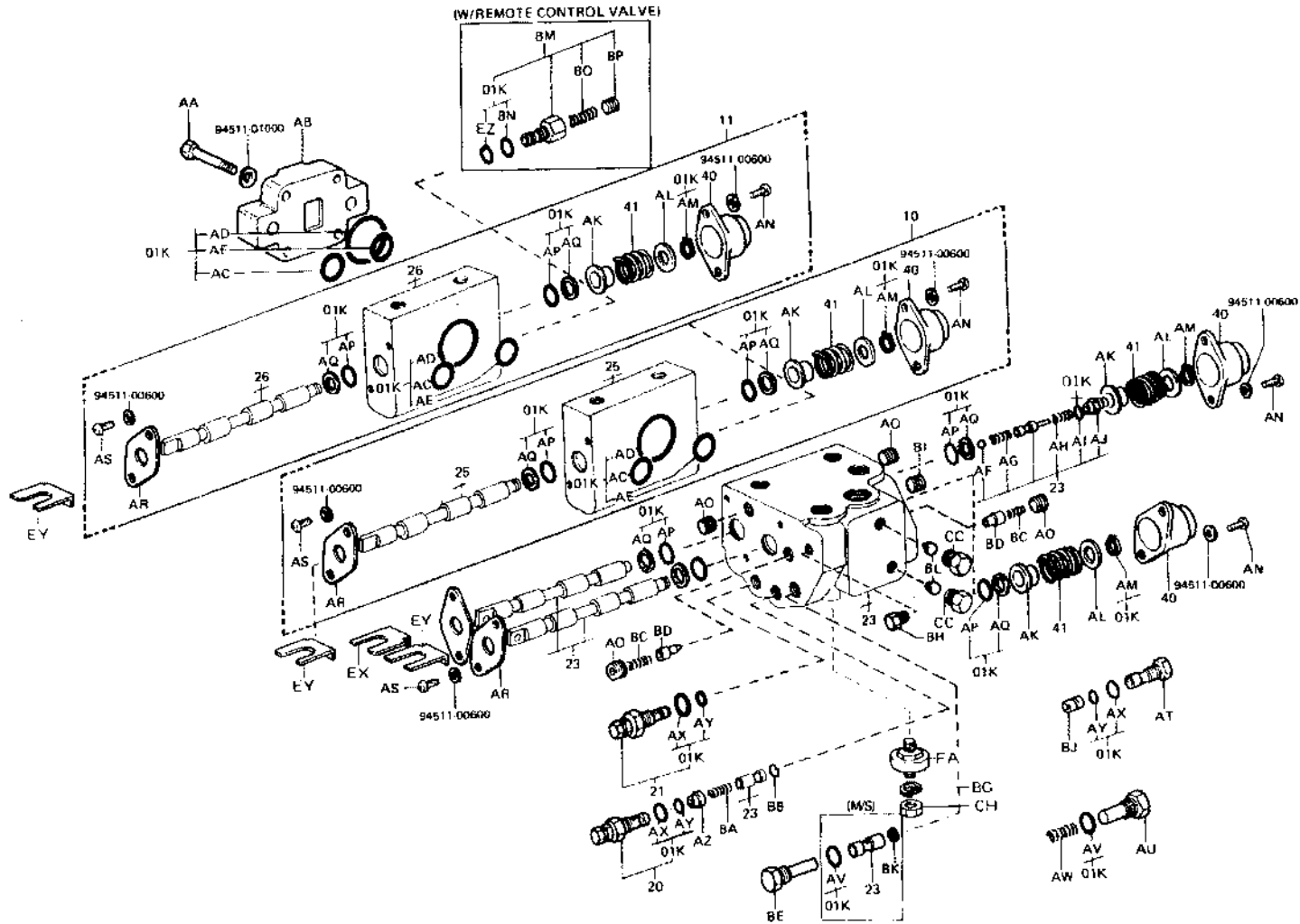





# 6705

PART NAME CODE	PART NAME	QTY
6705-01	VALVE ASSY, OIL CONTROL -----	1
6705-01K	VALVE O/H KIT, OIL CONTROL -----	1
6705-10	VALVE ASSY, PLUNGER SECTION, NO.1 -----	1
6705-11	VALVE ASSY, PLUNGER SECTION, NO.2 -----	1
6705-20	VALVE SEI, PILOT RELIEF, NO.1 -----	1
6705-21	VALVE SET, PILOT RELIEF, NO.2 -----	1
6705-23	HOUSING & SPOOL SET, NO.1 -----	1
6705-25	HOUSING & SPOOL SET, ATTACHMENT, NO.1 -----	1
6705-26	HOUSING & SPOOL SET, ATTACHMENT, NO.2 -----	1
6705-40	COVER, SPRING -----	2
6705-41	SPRING, COMPRESSION (FOR SPOOL RETURN) -----	2
6705-50A	RING, O, NO.1 (FOR VALVE FITTING) -----	2
6705-50B	RING, O, NO.2 (FOR VALVE FITTING) -----	1
6705-50C	RING, O, NO.3 (FOR VALVE FITTING) -----	2
6705-AA	BOLT -----	4
6705-AB	HOUSING, OUTLET -----	1
6705-AC	RING, O -----	1
6705-AD	RING, O -----	1
6705-AE	RING, O -----	1
6705-AF	BALL, STEEL -----	1
6705-AG	SPRING -----	1
6705-AH	SPRING, COMPRESSION -----	1
6705-AI	RING, O -----	1
6705-AJ	STOPPER -----	1
6705-AK	HOLDER, SPRING -----	2
6705-AL	WASHER, PLATE -----	2
6705-AM	RING, SHAFT SNAP -----	2
6705-AN	SCREW -----	4
6705-AO	PLUG -----	2
6705-AP	RING, O -----	4
6705-AQ	RING, BACK JP -----	4
6705-AR	HOLDER, SEAL -----	2
6705-AS	SCREW -----	4
6705-AT	STOPPER -----	1
6705-AU	STOPPER -----	1
6705-AV	RING, O -----	2
6705-AW	SPRING, COMPRESSION -----	1
6705-AX	RING, O -----	3
6705-AY	RING, O -----	3
6705-AZ	COLLAR -----	1
6705-BA	SPRING, COMPRESSION -----	1
6705-BB	WIRE, ORIFICE TURNING -----	1
6705-BC	SPRING, COMPRESSION -----	2
6705-BD	PLUNGER, CHECK -----	2
6705-BE	STOPPER -----	1
6705-BG	WASHER -----	4
6705-BH	PLUG -----	1
6705-BI	PLUG -----	1
6705-BJ	SEAT, VALVE -----	1
6705-BK	VALVE, CHECK -----	1
6705-BL	SEAT, INSERT -----	2
6705-BM	VALVE SUB-ASSY, RELIEF -----	1
6705-BN	RING, O -----	1

(FSV ) ( 8 ) G208

PART NAME CODE	PART NAME	QTY
6705-60	SPRING -----	1
6705-BP	STOPPER -----	1
6705-BQ	RING, O -----	2
6705-BR	RING, O -----	2
6705-BT	FITTING -----	1
6705-BU	FITTING -----	1
6705-BV	FITTING -----	2
6705-BW	FITTING -----	1
6705-BX	FITTING -----	2
6705-BY	FITTING -----	1
6705-BZ	PLUG -----	2
6705-CA	FITTING -----	1
6705-CC	PLUG -----	2
6705-CH	NUT -----	4
6705-DW	PLUG -----	1
6705-EX	BRACKET SUB-ASSY, TILT -----	1
6705-EY	BRACKET SUB-ASSY, LIFT -----	1
6705-EZ	RING, O -----	1
6705-FA	INSULATOR -----	4
6705-FN	FITTING -----	2

(FSV ) ( 9 ) G208

FIG. 6709 OIL CONTROL VALVE LINK

6709

FSV

FSV (3-WAY)

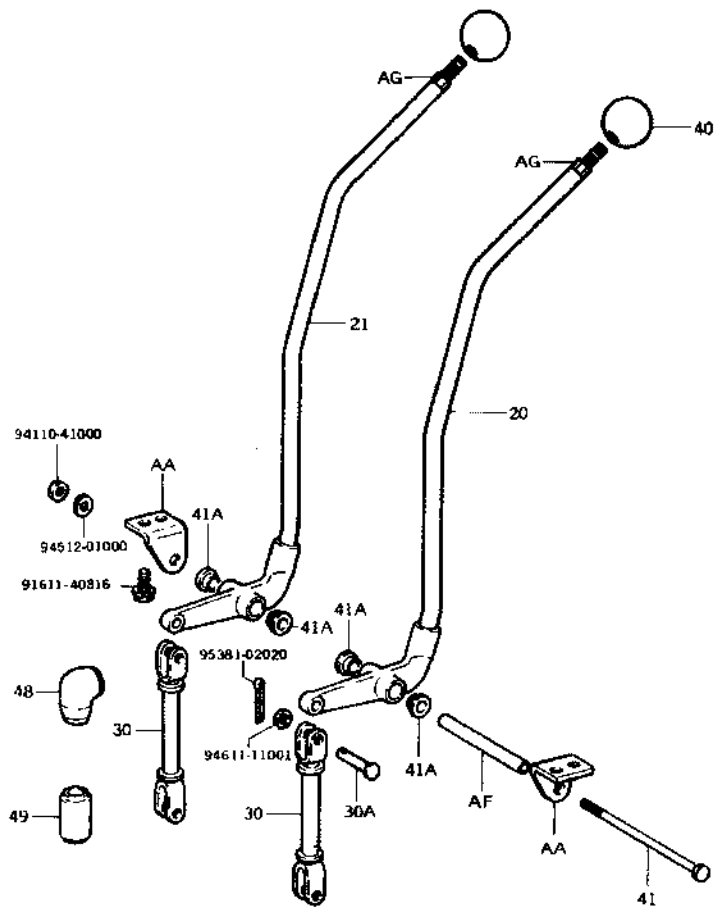

6709-018

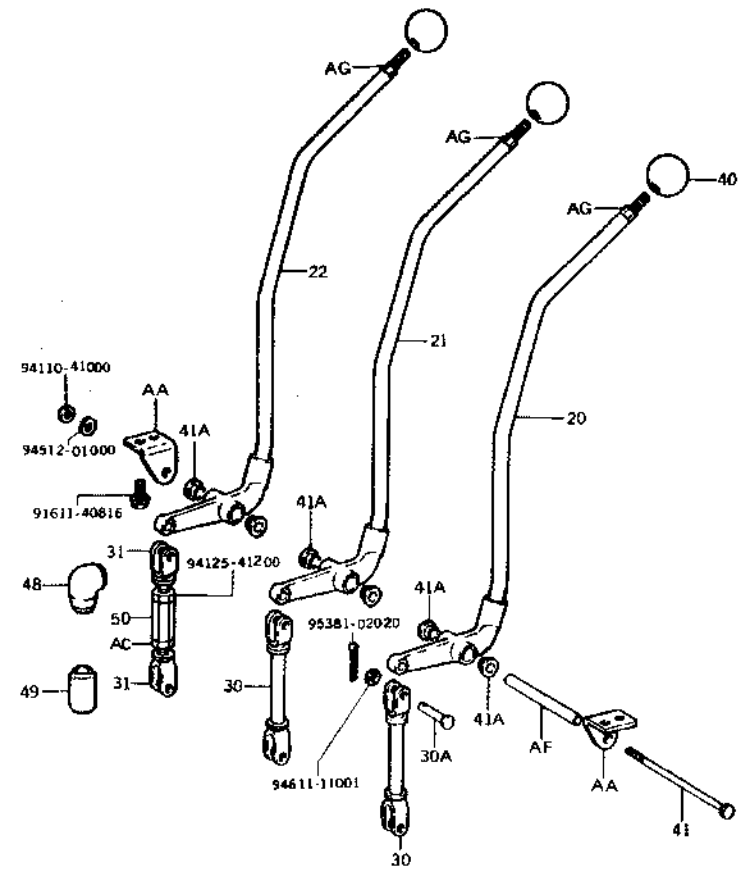

6709-017



FIG. 6709 OIL CONTROL VALVE LINK

**6709**

FSV (4-WAY)

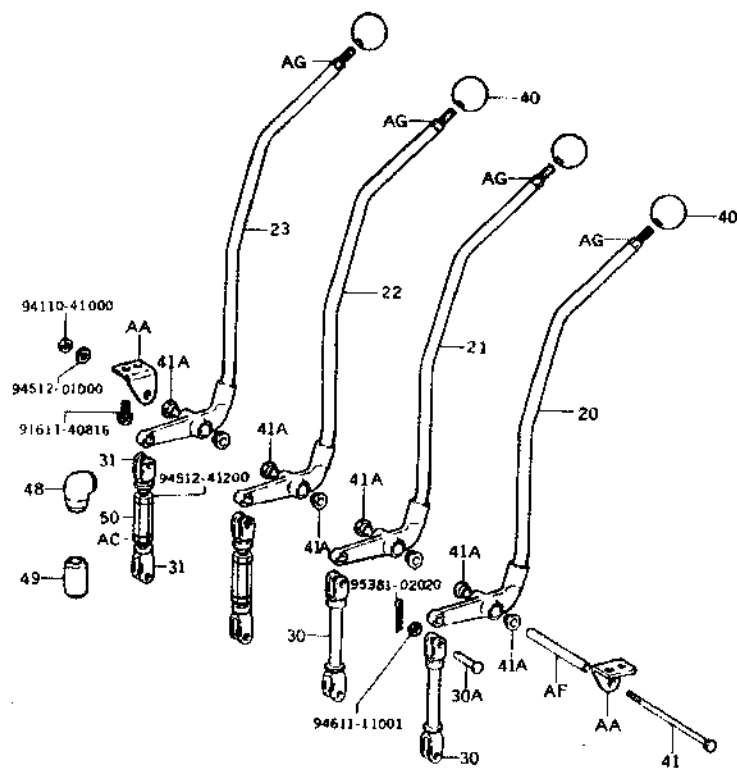

6709-014

PART NAME CODE	PART NAME	QTY
6709-20	LEVER SUB-ASSY, CONTROL VALVE, NO.1	1
6709-21	LEVER SUB-ASSY, CONTROL VALVE, NO.2	1
6709-22	LEVER SUB-ASSY, CONTROL VALVE, NO.3	1
6709-23	LEVER SUB-ASSY, CONTROL VALVE, NO.4	1
6709-30	ROD SUB-ASSY, CONTROL VALVE LEVER, NO.1	1
6709-30A	PIN (FOR CONTROL VALVE LEVER ROD)	4
6709-31	ROD SUB-ASSY, CONTROL VALVE LEVER, NO.2	1
6709-40	KNOB, OIL CONTROL VALVE LEVER	2
6709-41	PIN, OIL CONTROL VALVE LEVER	1
6709-41A	BUSH (FOR LEVER PIN)	4
6709-48	BOOT, CONTROL VALVE LINK, NO.1	2
6709-49	BOOT, CONTROL VALVE LINK, NO.2	2
6709-50	TURNBUCKLE	1
6709-AA	BRACKET SUB-ASSY	1
6709-AC	NUT	1
6709-AF	SPACER	1
6709-AG	BOLT, STUD	2

(FSV ) ( 10)

G208

FIG. 6801 BODY PIPING

6801

FSV

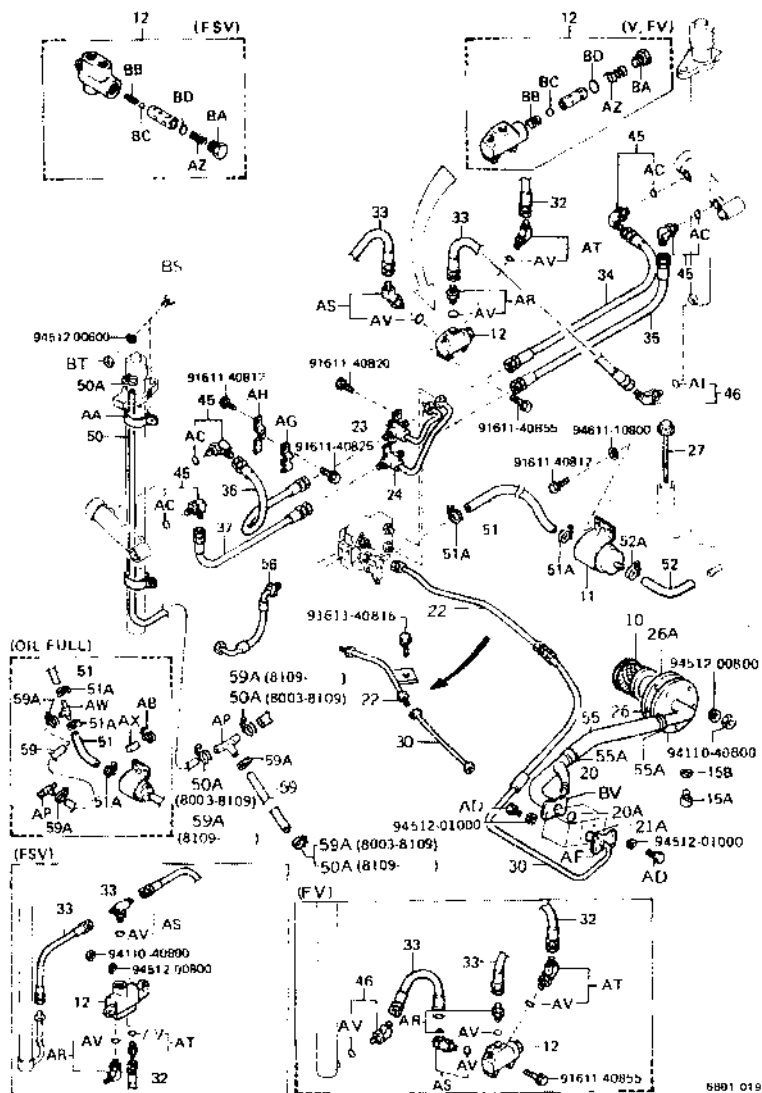

6891 019

PART NAME CODE	PART NAME	QTY
6801-10	FILTER ASSY, SUCTION	1
6801-11	FILTER ASSY, RETURN	1
6801-12	VALVE ASSY, FLOW REGULATOR	1
6801-15A	PLUG (FOR OIL TANK DRAIN)	1
6801-15B	GASKET (FOR OIL TANK DRAIN PLUG)	1
6801-20	PIPE SUB-ASSY (PUMP INLET)	1
6801-20A	RING, O (FOR OIL PUMP INLET)	1
6801-21A	RING, O (FOR OIL PUMP OUTLET)	1
6801-22	PIPE SUB-ASSY (PUMP TO VALVE)	1
6801-23	PIPE SUB-ASSY (TILT CYLINDER FRONT)	1
6801-24	PIPE SUB-ASSY (TILT CYLINDER REAR)	1
6801-26	OUTLET SUB-ASSY, OIL TANK	1
6801-26A	PACKING, OIL TANK COVER	1
6801-27	CAP SUB-ASSY, OIL TANK	1
6801-30	HOSE, HIGH PRESSURE, NO.1 (PUMP TO VALVE)	1
6801-32	HOSE, HIGH PRESSURE, NO.1 (VALVE TO LIFT)	1
6801-33	HOSE, HIGH PRESSURE, NO.2 (VALVE TO LIFT)	2
6801-34	HOSE, HIGH PRESSURE, NO.1 (TILT FRONT)	1
6801-35	HOSE, HIGH PRESSURE, NO.1 (TILT REAR)	1
6801-36	HOSE, HIGH PRESSURE, NO.2 (TILT FRONT)	1
6801-37	HOSE, HIGH PRESSURE, NO.2 (TILT REAR)	1
6801-45	FITTING (FOR TILT CYLINDER)	2
6801-46	FITTING (FOR LIFT CYLINDER)	2
6801-50	HOSE, LOW PRESSURE, NO.1 (LIFT TO TANK)	2
6801-50A	CLAMP (FOR LIFT TO TANK NO.1 HOSE)	3- 4
6801-51	HOSE, LOW PRESSURE, NO.1 (VALVE TO TANK)	1
6801-51A	CLAMP (FOR VALVE TO TANK NO.1 HOSE)	2
6801-52	HOSE, LOW PRESSURE, NO.2 (VALVE TO TANK)	1
6801-52A	CLAMP (FOR VALVE TO TANK NO.2 HOSE)	2
6801-55	HOSE, LOW PRESSURE (TANK TO PUMP)	1
6801-55A	CLAMP (FOR TANK TO PUMP HOSE)	2
6801-56	HOSE, LOW PRESSURE (STEERING TO VALVE)	1
6801-59	HOSE, LOW PRESSURE, NO.2 (LIFT TO TANK)	1
6801-59A	CLAMP (FOR LIFT TO TANK NO.2 HOSE)	2- 3
6801-AA	BAND, LIFT CYLINDER OVERFLOW HOSE	4
6801-AB	CLAMP	1
6801-AC	RING, O	4
6801-AD	BOLT	8
6801-AF	FLANGE, SPLIT	1
6801-AG	CLAMP	1
6801-AH	BRACKET SUB-ASSY, TILT HOSE	1
6801-AI	RING, O	2
6801-AP	PIPE	1
6801-AR	FITTING	1
6801-AS	FITTING	1
6801-AT	FITTING	1
6801-AV	RING, O	3
6801-AW	ELBOW SUB-ASSY, 3-WAY	1
6801-AZ	SPRING, COMPRESSION	1
6801-BA	PLUG	1
6801-BB	SPRING, COMPRESSION	1
6801-BC	BALL, STEEL	1
6801-BD	RING, O	1

(FSV ) ( 11)

G208

**6801**

PART NAME CODE	PART NAME	QTY
6801-BS	BOLT -----	5
6801-BI	WASHER -----	5
6801-BV	FLANGE -----	2

(FSV ) ( 12)

G208

FIG. 6802 MAST PIPING

**6802**

FSV

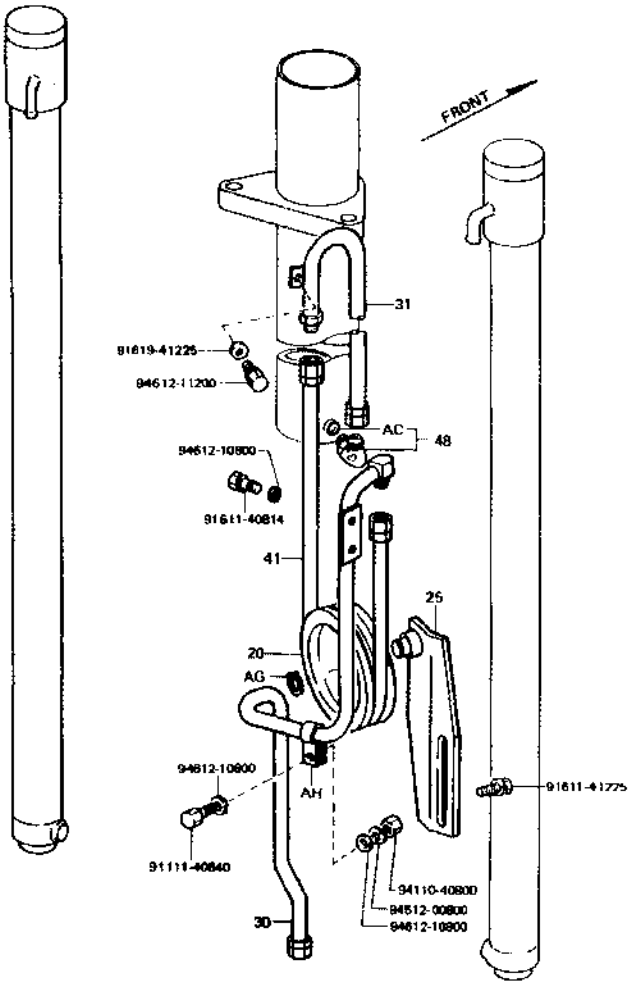

6802-003

PART NAME CODE	PART NAME	QTY
6802-20	PULLEY SUB-ASSY, HOSE GUIDE, NO.1 -----	1
6802-25	BRACKET SUB-ASSY, GUIDE PULLEY -----	1
6802-30	PIPE SUB-ASSY, NO.1 (FRONT LIFT) -----	1
6802-31	PIPE SUB-ASSY, NO.2 (FRONT LIFT) -----	1
6802-41	HOSE, HIGH PRESSURE, NO.1 (FRONT LIFT) -----	1
6802-48	FITTING (FOR FRONT LIFT CYLINDER) -----	1
6802-AC	RING, O -----	1
6802-AG	RING, SHAFT SNAP -----	1
6802-AH	CLAMP -----	1

FIG. 6101 MAST

**6101**

FV

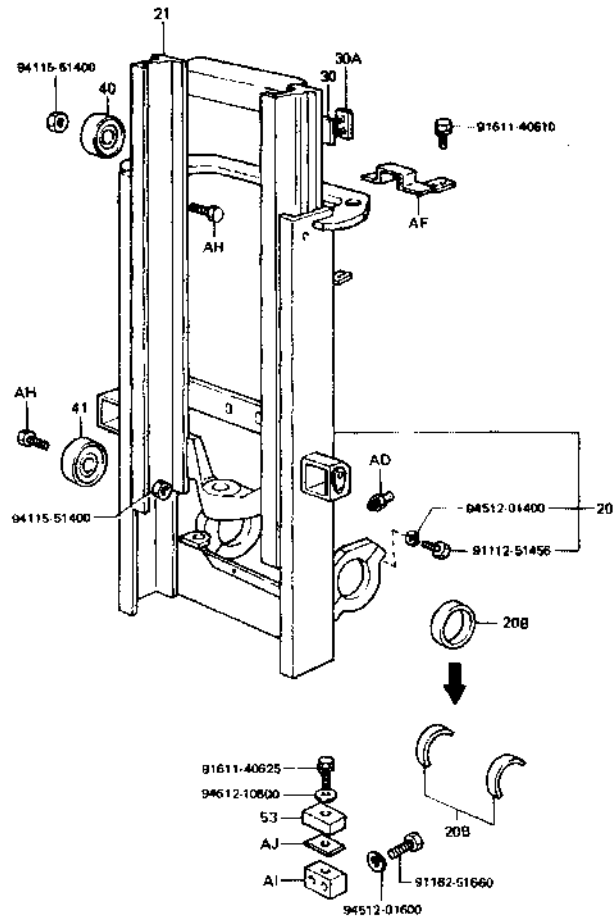

6101-667

PART NAME CODE	PART NAME	QTY
6101-20	MAST SUB-ASSY, OUTER -----	1
6101-20B	BUSH, MAST SUPPORT -----	1
6101-21	MAST SUB-ASSY, INNER -----	1
6101-30	STRIP SUB-ASSY, OUTER MAST -----	2
6101-30A	SHIM, OUTER MAST STRIP -----	99
6101-40	ROLLER, LIFT (FOR OUTER MAST) -----	2
6101-41	ROLLER, LIFT (FOR INNER MAST) -----	2
6101-53	CUSHION, MAST (FOR INNER MAST) -----	2
6101-AD	FITTING, GREASE -----	2
6101-AF	COVER, ROLLER -----	1
6101-AH	BOLT -----	4
6101-AI	STOPPER -----	2
6101-AJ	SHIM, STOPPER -----	6

(FV ) ( 1 )

G208

FIG. 6301 LIFT BRACKET & FORK

6301

FV

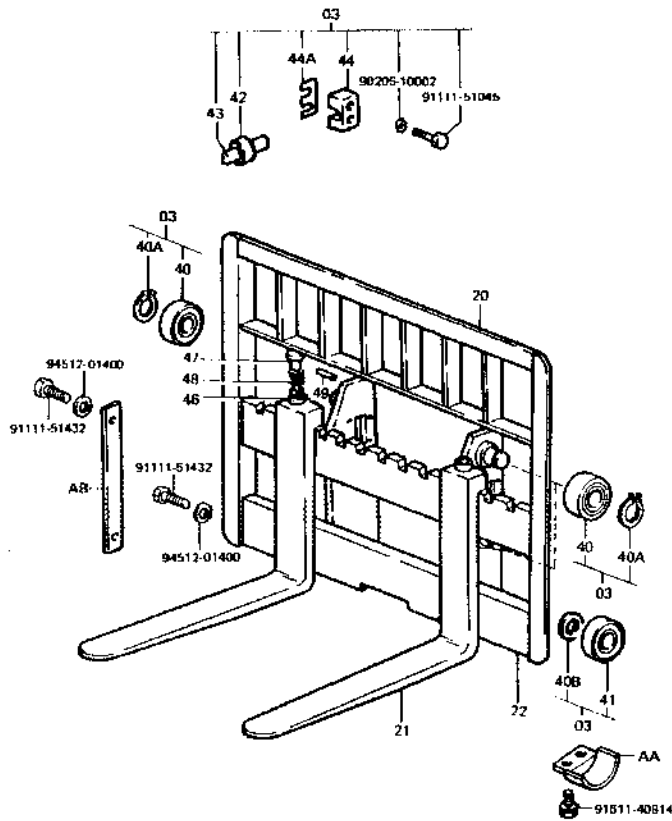

6301 004A

PART NAME CODE	PART NAME	QTY
6301-03	BRACKET ASSY, LIFT -----	1
6301-20	BACKREST SUB-ASSY -----	1
6301-21	FORK SUB-ASSY -----	2
6301-22	BRACKET SUB-ASSY, LIFT -----	1
6301-40	ROLLER, LIFT (UPPER, LOWER) -----	4
6301-40A	RING, SHAFT SNAP (UPPER, LOWER) -----	4
6301-40B	SHIM, LIFT ROLLER -----	99
6301-41	ROLLER, LIFT (CENTER) -----	2
6301-42	ROLLER, SIDE -----	2
6301-43	SHAFT, SIDE ROLLER -----	2
6301-44	HOLDER, SIDE ROLLER SHAFT -----	4
6301-44A	SHIM (FOR SHAFT HOLDER) -----	99
6301-46	PIN, FORK STOPPER -----	2
6301-47	KNOB, FORK STOPPER PIN -----	2
6301-48	SPRING, FORK STOPPER PIN -----	2
6301-49	PIN, SPRING (FOR FORK STOPPER PIN) -----	2
6301-AA	COVER, LIFT BRACKET ROLLER -----	4
6301-AB	PLATE, SIDE -----	2

(FV ) ( 2 )

G208



FIG. 6302 CHAIN & CHAIN WHEEL

**6302**

FV

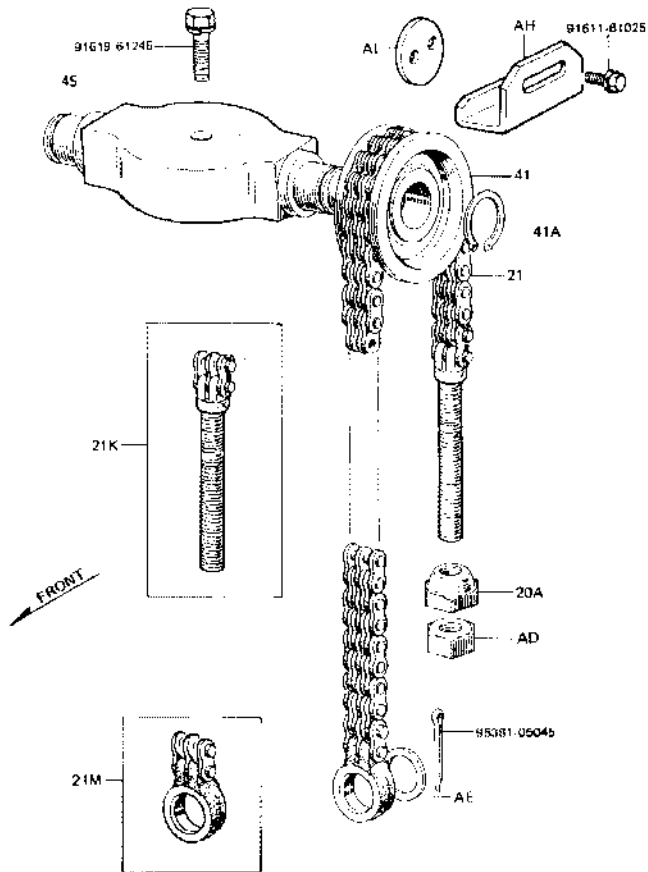

6302 004

PART NAME CODE	PART NAME	QTY
6302-20A	NUT, CHAIN ADJUST -----	2
6302-21	CHAIN SUB-ASSY (FRONT) -----	2
6302-21K	BOLT KIT, CHAIN ANCHOR, NO.1 (FRONT) -----	2
6302-21M	BOLT KIT, CHAIN LYL (FRONT) -----	2
6302-41	WHEEL, CHAIN (FRONT) -----	2
6302-41A	RING, SHAFT SNAP (FOR FRONT CHAIN WHEEL) -----	2
6302-45	SUPPGRT, CHAIN WHEEL -----	1
6302-AD	NUT, HEXAGON -----	2
6302-AE	WASHER, CHAIN SPLITAL -----	2
6302-AH	COVER, CHAIN WHEEL -----	2
6302-AI	SPACER -----	4

(FV ) ( 3 )

G208

FIG. 6502 FRONT LIFT CYLINDER

**6502**

FV

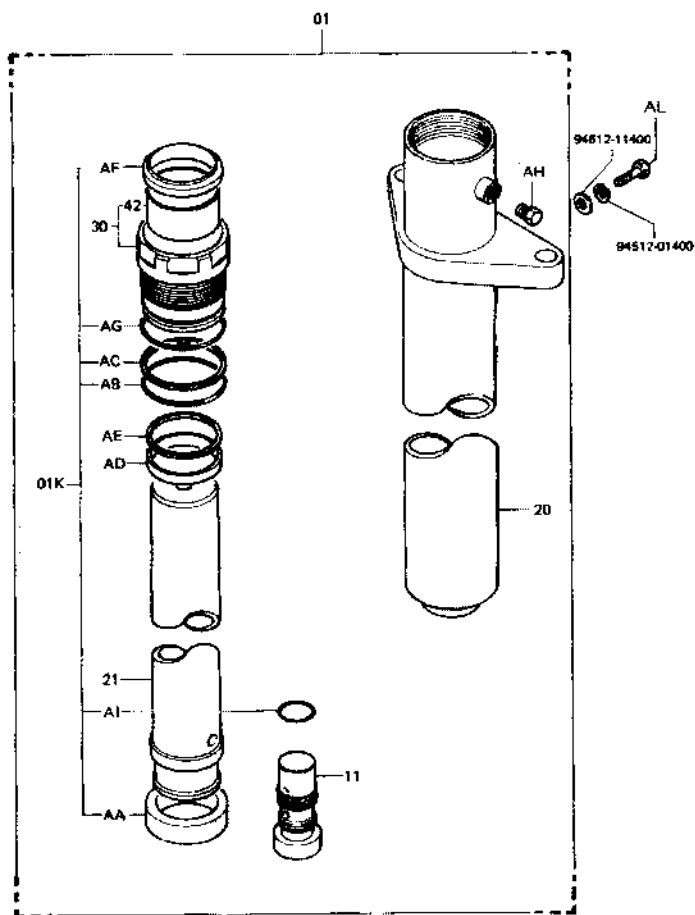

6502-001A

PART NAME CODE	PART NAME	QTY
6502-01	CYLINDER ASSY, LIFT	1
6502-01K	CYLINDER O/H KIT, LIFT	1
6502-11	VALVE ASSY, SAFETY DOWN	1
6502-20	CYLINDER SUB-ASSY, LIFT	1
6502-21	ROD SUB-ASSY, LIFT CYLINDER	1
6502-30	GUIDE SUB-ASSY, LIFT CYLINDER ROD	1
6502-42	SLEEVE, LIFT CYLINDER ROD GUIDE	1
6502-AA	BUSHING	1
6502-AB	RING, O	1
6502-AC	RING, BACK UP	1
6502-AD	PACKING, U	1
6502-AE	RING, BACK UP	1
6502-AF	SEAL, DUST	1
6502-AG	RING, O	1
6502-AH	PLUG	1
6502-AI	RING, O	1
6502-AL	BOLT	2

FIG. 6503 REAR LIFT CYLINDER

# 6503

FV

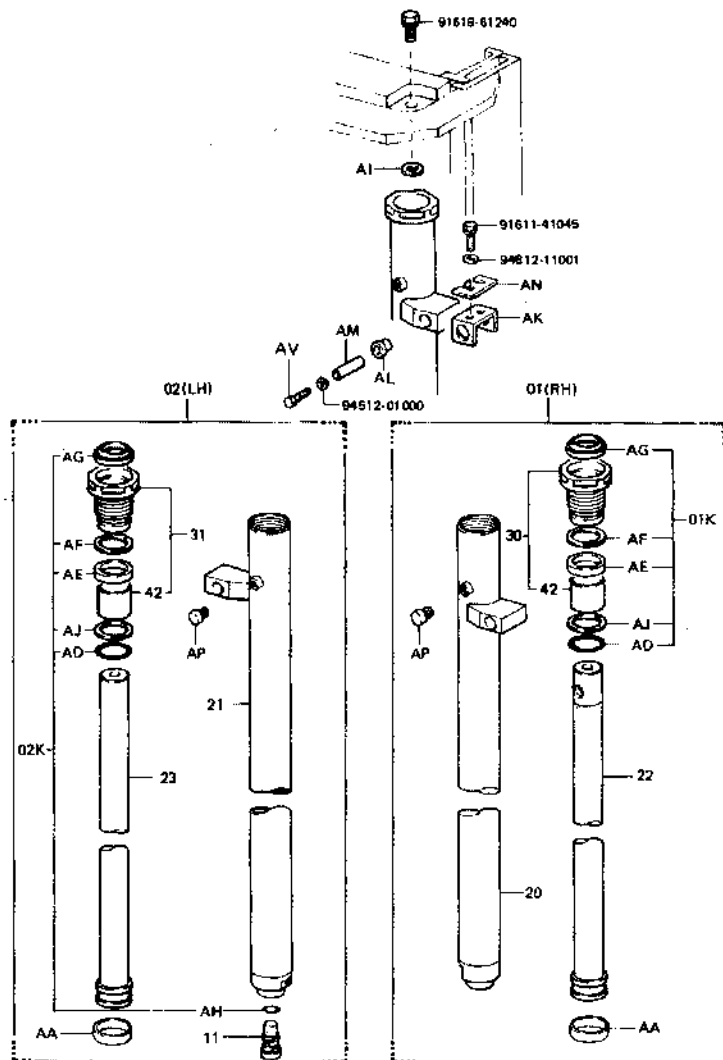

PART NAME CODE	PART NAME	QTY
6503-01	CYLINDER ASSY, LIFT, RH	1
6503-01K	CYLINDER O/H KIT, LIFT, RH	1
6503-02	CYLINDER ASSY, LIFT, LH	1
6503-02K	CYLINDER O/H KIT, LIFT, LH	1
6503-11	VALVE ASSY, SAFETY DOWN	1
6503-20	CYLINDER SUB-ASSY, LIFT, RH	1
6503-21	CYLINDER SUB-ASSY, LIFT, LH	1
6503-22	ROD SUB-ASSY, LIFT CYLINDER, RH	1
6503-23	ROD SUB-ASSY, LIFT CYLINDER, LH	1
6503-30	GUIDE SUB-ASSY, LIFT CYLINDER ROD, RH	1
6503-31	GUIDE SUB-ASSY, LIFT CYLINDER ROD, LH	1
6503-42	SLEEVE, LIFT CYLINDER ROD GUIDE	2
6503-AA	RING, WEAR	2
6503-AD	RING, O	2
6503-AE	PACKING, U	2
6503-AF	RING, O	2
6503-AG	SEAL, DUST	2
6503-AH	RING, O	1
6503-AI	SHIM	3
6503-AJ	RING, BACK UP	2
6503-AK	BRACKET SUB-ASSY, LIFT CYLINDER	2
6503-AL	BUSHING	4
6503-AM	SPACER	2
6503-AN	SHIM	6
6503-AP	PLUG	2
6503-AV	BOLT	2

FIG. 6511 TILT CYLINDER

6511

FV

FV

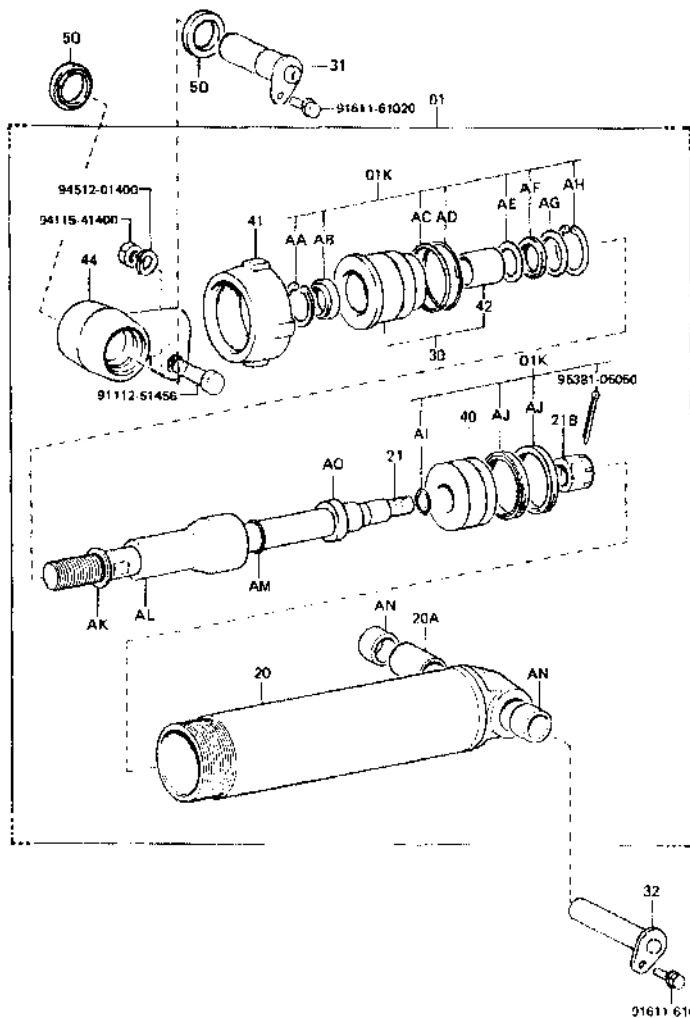

91611-61020

6511-010

テイルト角度表  
TABLE OF TILT RANGE

生産期間 PROD DATE	型式 MODELS	タイヤ TIRE	揚 高 LIFTING HEIGHT	備 考 DESCRIPTION	テイルト角 TILT RANGE
8003-	F, FV, M, SV, V	SINGLE	H2000-H4000		6D - 12D
8003-	F, FV, M, SV, V	DOUBLE	H2000-H4500		6D - 12D
8003-	F, FV, M, SV, V	SINGLE	H4500-H5000		6D - 6D
8003-	F, FV, M, SV, V	DOUBLE	H5000		8D - 8D
8003-	F, FV, M, SV, V		H2000	FRONT GLASS	6D - 10D
8003-	FSV, FS		H3700-H4700	DOMESTIC	6D - 8D
8003-	FSV, FS		H5000-H6500	DOMESTIC	3D - 6D
8003-	FSV, FS		H3700-H6500	EXPORT	6D - 6D
8003-	F, FV, M, SV, V	SINGLE	H2000-H4000	AUSTRALIA	3D - 12D
8003-	F, FV, M, SV, V	DOUBLE	H2000-H4500	AUSTRALIA	3D - 12D
8003-	F, FV, M, SV, V	SINGLE	H4500-H5000	AUSTRALIA	3D - 6D
8003-	F, FV, M, SV, V	DOUBLE	H5000	AUSTRALIA	3D - 6D
8003-	F, FV, M, SV, V		H2000	FRONT GLASS AUSTRALIA	3D - 6D
8003-	FV, M, SV, V		H3700-H6500	AUSTRALIA	3D - 8D

6511-01B

FIG. 6511 TILT CYLINDER

6511

FV

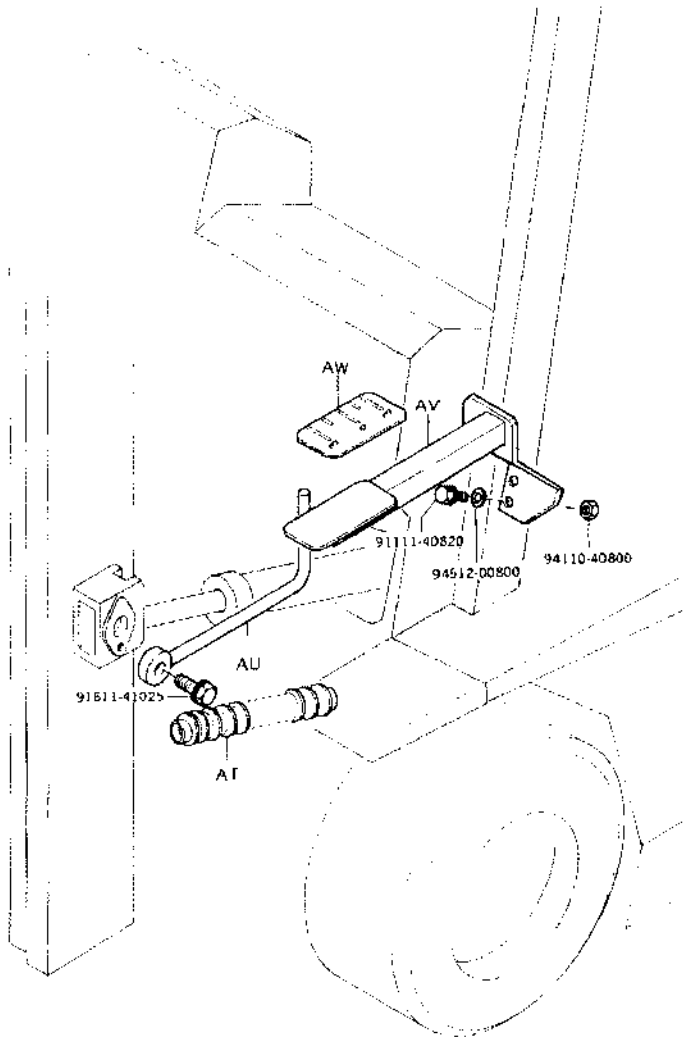

6511-012

PART NAME CODE	PART NAME	QTY
6511-01	CYLINDER ASSY, TILT	2
6511-01K	CYLINDER O/H KIT, TILT	2
6511-20	CYLINDER SUB-ASSY, TILT	2
6511-20A	BUSH, PIN (FOR CYLINDER)	2
6511-21	ROD SUB-ASSY, TILT CYLINDER PISTON	2
6511-21B	NUT, CASTLE	2
6511-30	GUIDE SUB-ASSY, TILT CYLINDER ROD	2
6511-31	PIN SUB-ASSY, TILT CYLINDER, FR	2
6511-32	PIN SUB-ASSY, TILT CYLINDER, RR	2
6511-40	PISTON, TILT CYLINDER	2
6511-41	COVER, TILT CYLINDER	2
6511-42	SLEEVE, TILT CYLINDER ROD GUIDE	2
6511-44	JOINT, PISTON ROD	2
6511-50	SEAL, GREASE	4
6511-AA	RING, HOLE SNAP	2
6511-AB	SEAL, DUST	2
6511-AC	RING, BACK UP	2
6511-AD	RING, O	2
6511-AF	RING, BACK UP	2
6511-AF	PACKING, U	2
6511-AG	PLATE, STOPPER	2
6511-AH	RING, HOLE SNAP	2
6511-AI	RING, O	2
6511-AJ	PACKING, U	4
6511-AK	SHIM, TILT CONTROL	99
6511-AL	SPACER, TILT CONTROL	2
6511-AM	RING, O	4
6511-AN	COLLAR	4
6511-AU	SPACER, TILT CONTROL	2
6511-AT	BOOT SUB-ASSY	2
6511-AU	BAR SUB-ASSY, TILT GAUGE	1
6511-AV	BRACKET SUB-ASSY, TILT GAUGE	1
6511-AW	PLATE, TILT CYLINDER INDICATOR	1

(FV ) ( 6)

G208

FIG. 6701 OIL PUMP

**6701**

FV

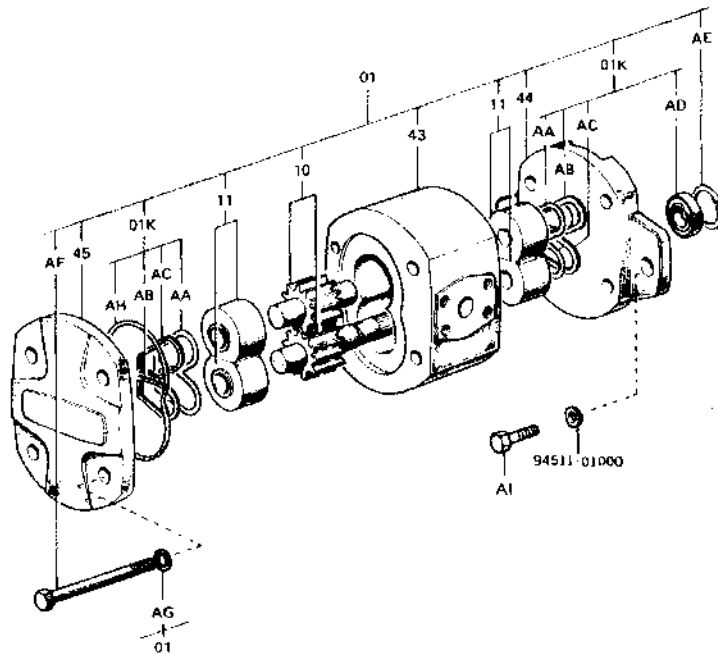

6701-018

PART NAME CODE	PART NAME	QTY
6701-01	PUMP ASSY, OIL -----	1
6701-01K	PUMP O/H KIT, OIL -----	1
6701-10	GEAR SET -----	1
6701-11	BUSH SET, NO.1 -----	2
6701-43	BODY -----	1
6701-44	FLANGE, MOUNTING -----	1
6701-45	COVER -----	1
6701-AA	SEAL, BUSHING -----	2
6701-AB	RING, BACKING, RH -----	2
6701-AC	RING, BACKING, LH -----	2
6701-AD	SEAL, OIL -----	1
6701-AE	RING, SNAP -----	1
6701-AF	BOLT -----	4
6701-AG	WASHER, SPRING -----	4
6701-AH	SEAL, BODY -----	2
6701-AI	BOLT -----	2

(FV ) ( 7 )

G208







FIG. 6705 OIL CONTROL VALVE

# 6705

FV (3-WAY..UL)

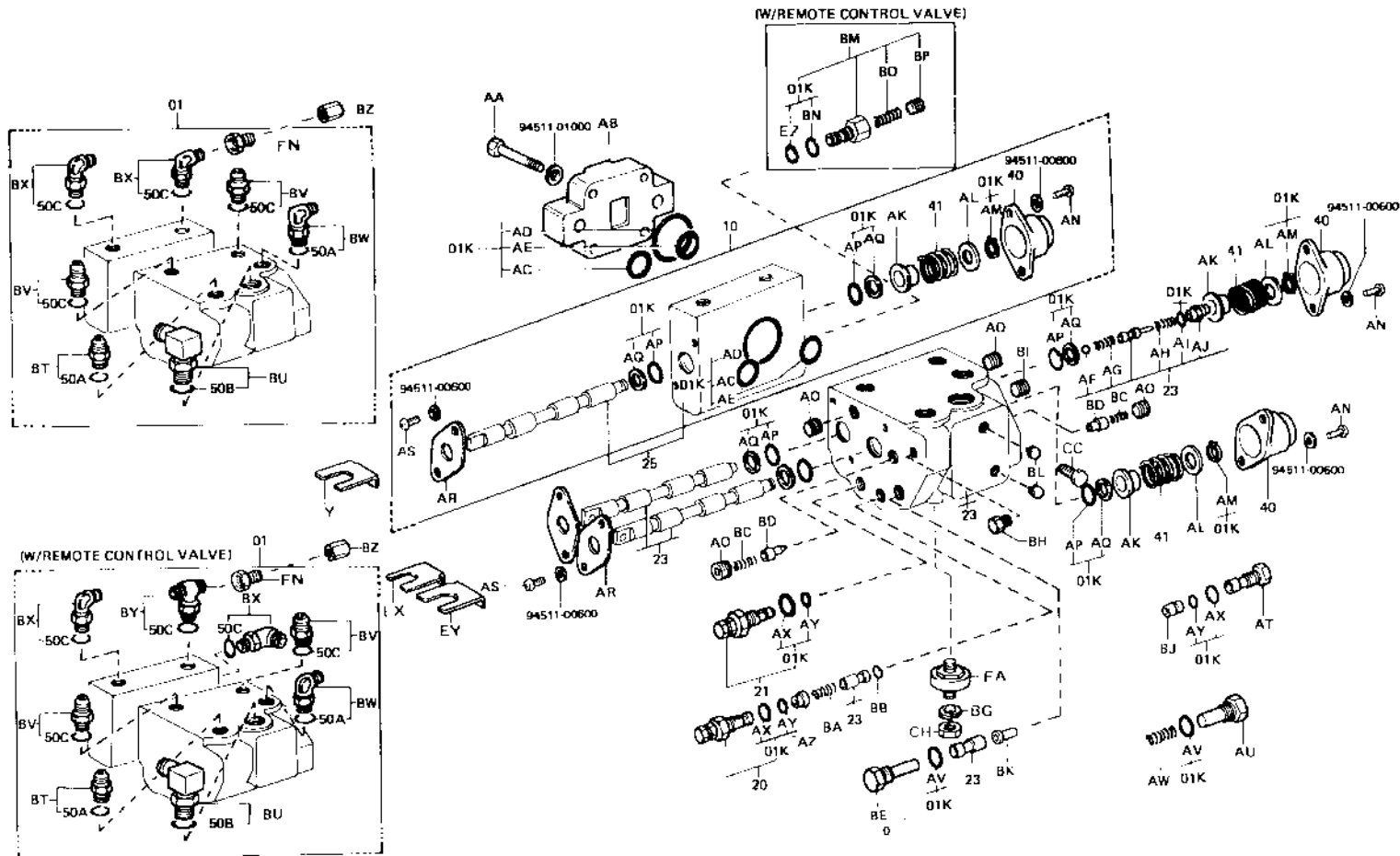
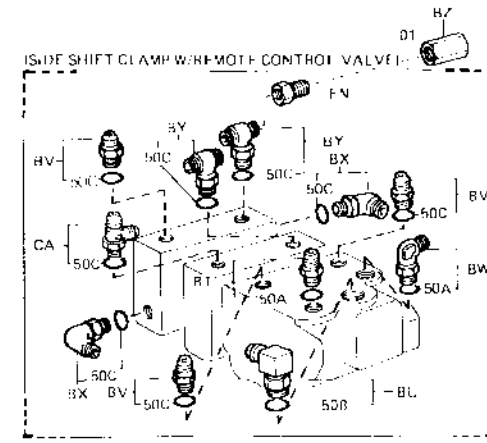
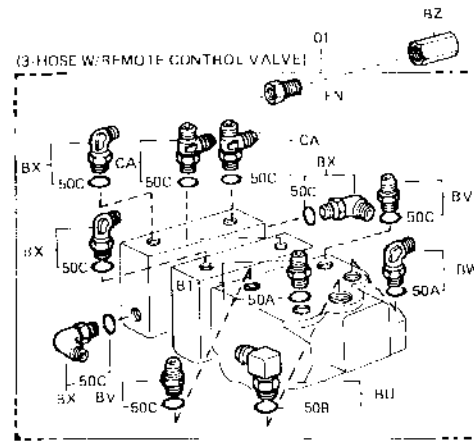
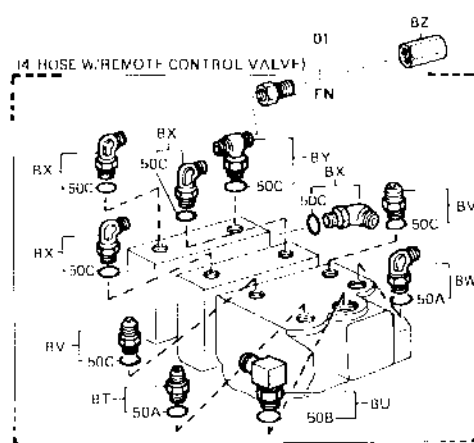
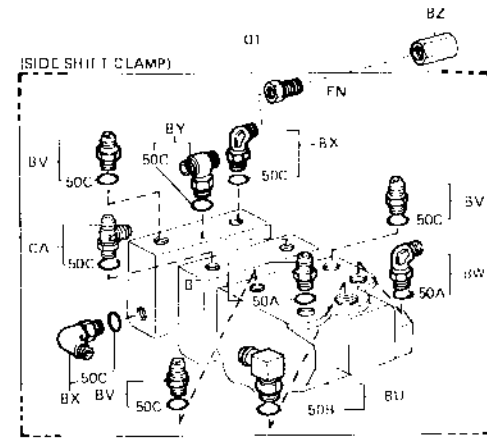
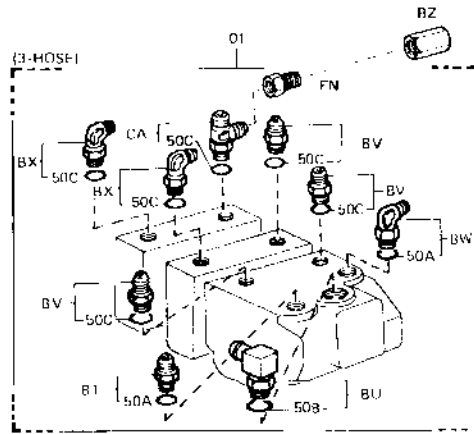
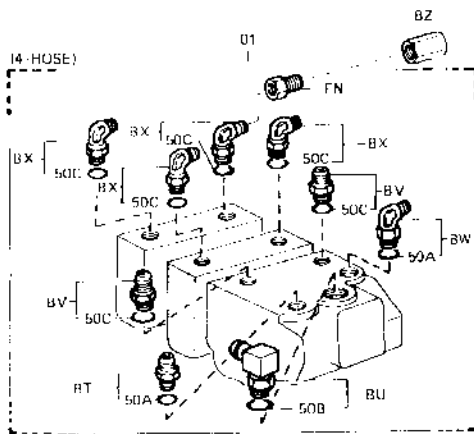



FIG. 6705 OIL CONTROL VALVE

6705

FV (4-WAY)



6705 050



FIG. 6705 OIL CONTROL VALVE

6705

FV (4-WAY...ULI)

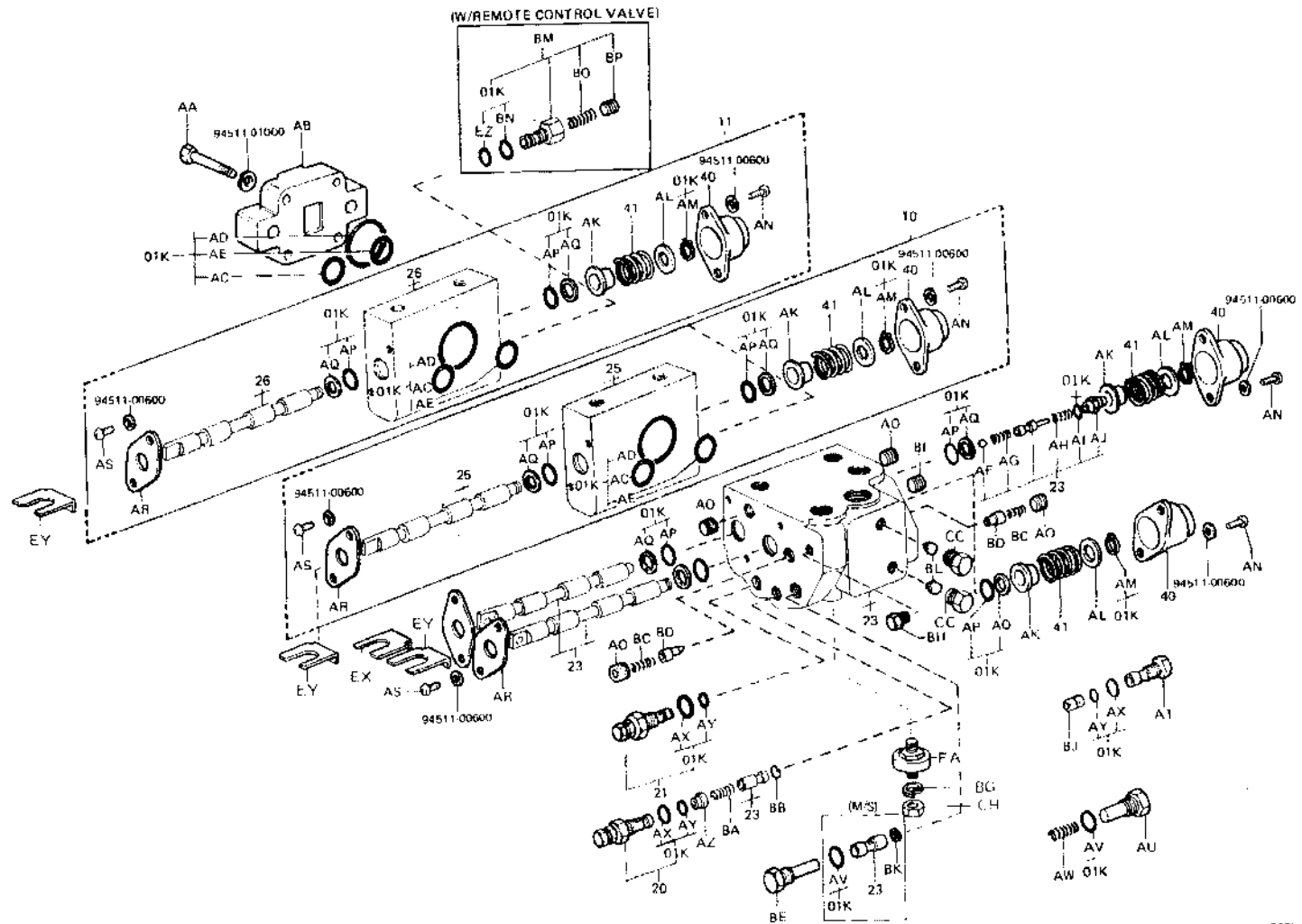
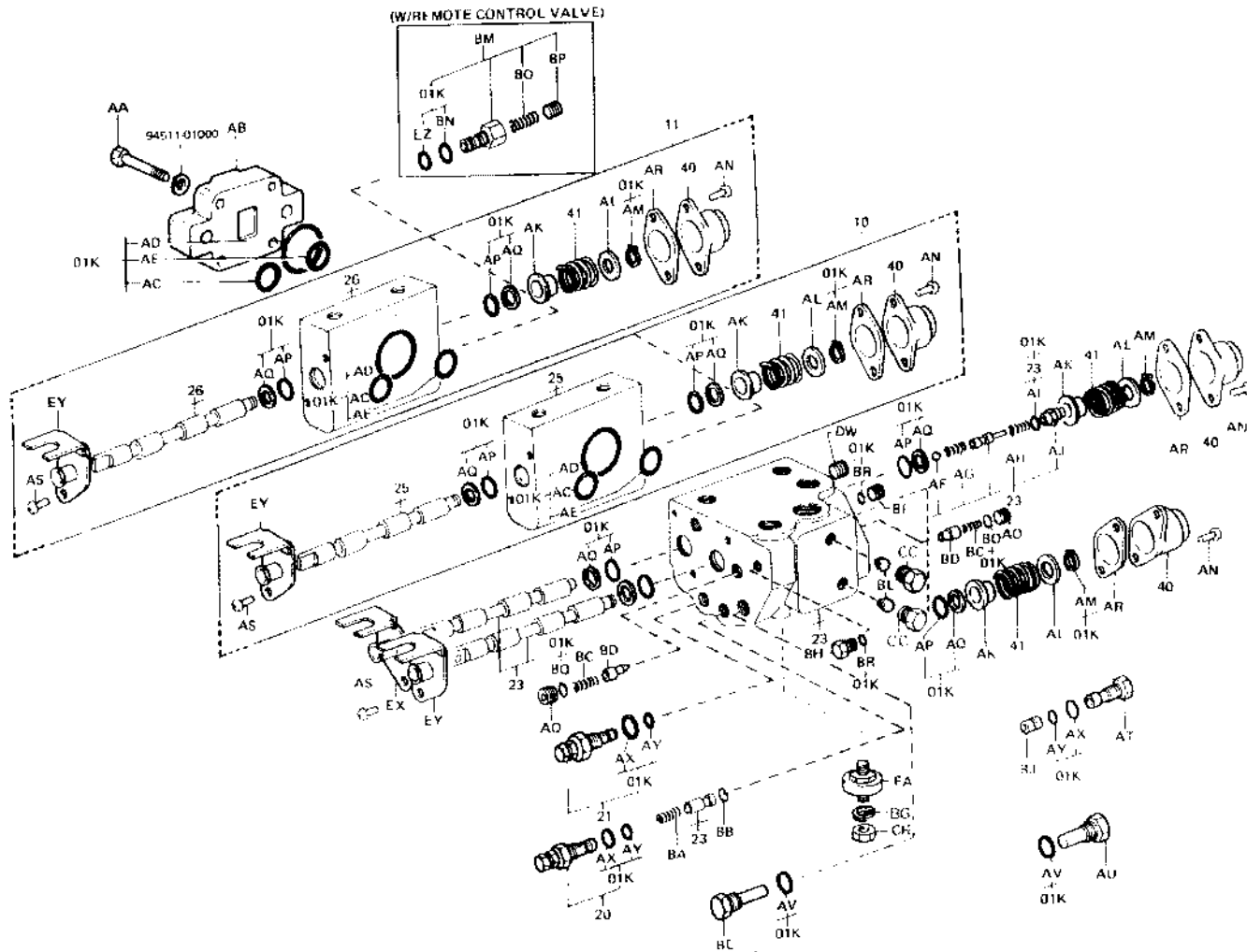

FIG. 6705 OIL CONTROL VALVE

6705

FV (4-WAY)



# 6705

PART NAME CODE	PART NAME	QTY
6705-01	VALVE ASSY, OIL CONTROL -----	1
6705-01K	VALVE O/H KIT, OIL CONTROL -----	1
6705-10	VALVE ASSY, PLUNGER SECTION, NO.1 -----	1
6705-11	VALVE ASSY, PLUNGER SECTION, NO.2 -----	1
6705-20	VALVE SET, PILOT RELIEF, NO.1 -----	1
6705-21	VALVE SET, PILOT RELIEF, NO.2 -----	1
6705-23	HOUSING & SPOOL SET, NO.1 -----	1
6705-25	HOUSING & SPOOL SET, ATTACHMENT, NO.1 -----	1
6705-26	HOUSING & SPOOL SET, ATTACHMENT, NO.2 -----	1
6705-40	COVER, SPRING -----	2
6705-41	SPRING, COMPRESSION (FOR SPOOL RETURN) -----	2
6705-50A	RING, O, NO.1 (FOR VALVE FITTING) -----	2
6705-50B	RING, O, NO.2 (FOR VALVE FITTING) -----	1
6705-50C	RING, O, NO.3 (FOR VALVE FITTING) -----	2
6705-AA	BOLT -----	4
6705-AB	HOUSING, OUTLET -----	1
6705-AC	RING, O -----	1
6705-AD	RING, O -----	1
6705-AE	RING, O -----	1
6705-AF	BALL, STEEL -----	1
6705-AG	SPRING -----	1
6705-AH	SPRING, COMPRESSION -----	1
6705-AI	RING, O -----	1
6705-AJ	STOPPER -----	1
6705-AK	HOLDER, SPRING -----	2
6705-AL	WASHER, PLATE -----	2
6705-AM	RING, SHAFT SNAP -----	2
6705-AN	SCREW -----	4
6705-AO	PLUG -----	2
6705-AP	RING, O -----	4
6705-AQ	RING, BACK UP -----	4
6705-AR	HOLDER, SEAL -----	2
6705-AS	SCREW -----	4
6705-AT	STOPPER -----	1
6705-AU	STOPPER -----	1
6705-AV	RING, O -----	2
6705-AW	SPRING, COMPRESSION -----	1
6705-AX	RING, O -----	3
6705-AY	RING, O -----	3
6705-AZ	COLLAR -----	1
6705-BA	SPRING, COMPRESSION -----	1
6705-BB	WIRE, ORIFICE TURNING -----	1
6705-BC	SPRING, COMPRESSION -----	2
6705-BD	PLUNGER, CHECK -----	2
6705-BE	STOPPER -----	1
6705-BG	WASHER -----	4
6705-BH	PLUG -----	1
6705-BI	PLUG -----	1
6705-BJ	SEAT, VALVE -----	1
6705-BK	VALVE, CHECK -----	1
6705-BL	SEAT, INSERT -----	2
6705-BM	VALVE SUB-ASSY, RELIEF -----	1
6705-BN	RING, O -----	1

(FV ) ( 8 ) G208

PART NAME CODE	PART NAME	QTY
6705-B0	SPRING -----	1
6705-BP	STOPPER -----	1
6705-BQ	RING, O -----	2
6705-BR	RING, O -----	2
6705-BT	FITTING -----	1
6705-BU	FITTING -----	1
6705-BV	FITTING -----	2
6705-BW	FITTING -----	1
6705-BX	FITTING -----	2
6705-BY	FITTING -----	1
6705-BZ	PLUG -----	2
6705-CA	FITTING -----	1
6705-CC	PLUG -----	2
6705-CH	NUT -----	4
6705-DW	PLUG -----	1
6705-EX	BRACKET SUB-ASSY, TILT -----	1
6705-EY	BRACKET SUB-ASSY, LIFT -----	1
6705-EZ	RING, O -----	1
6705-FA	INSULATOR -----	4
6705-FN	FITTING -----	2

(FV ) ( 9 ) G208

FIG. 6709 OIL CONTROL VALVE LINK

6709

FV

FV (3-WAY)

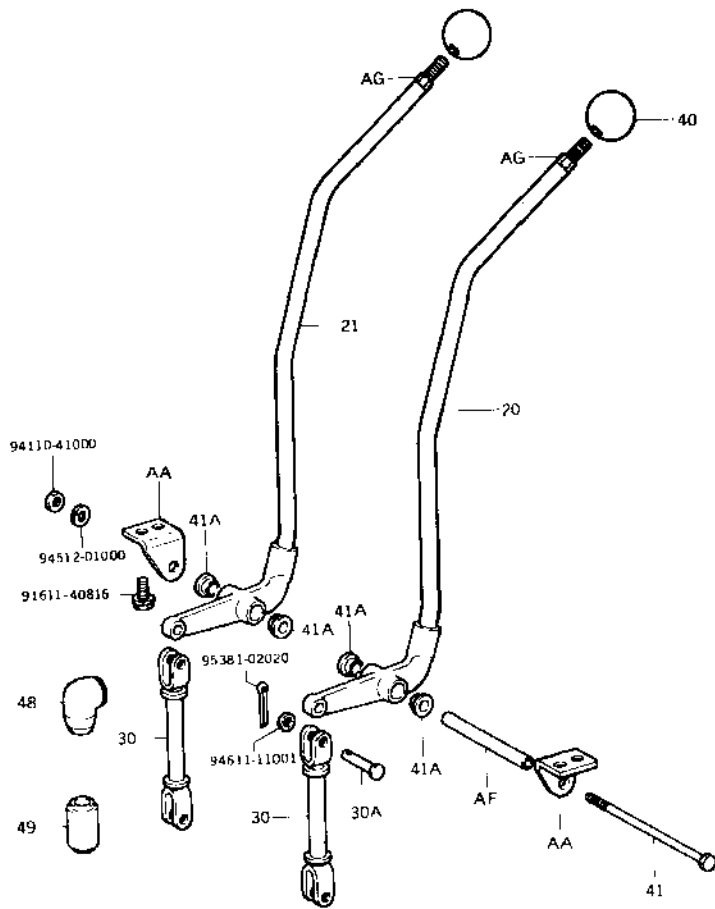

6709 016

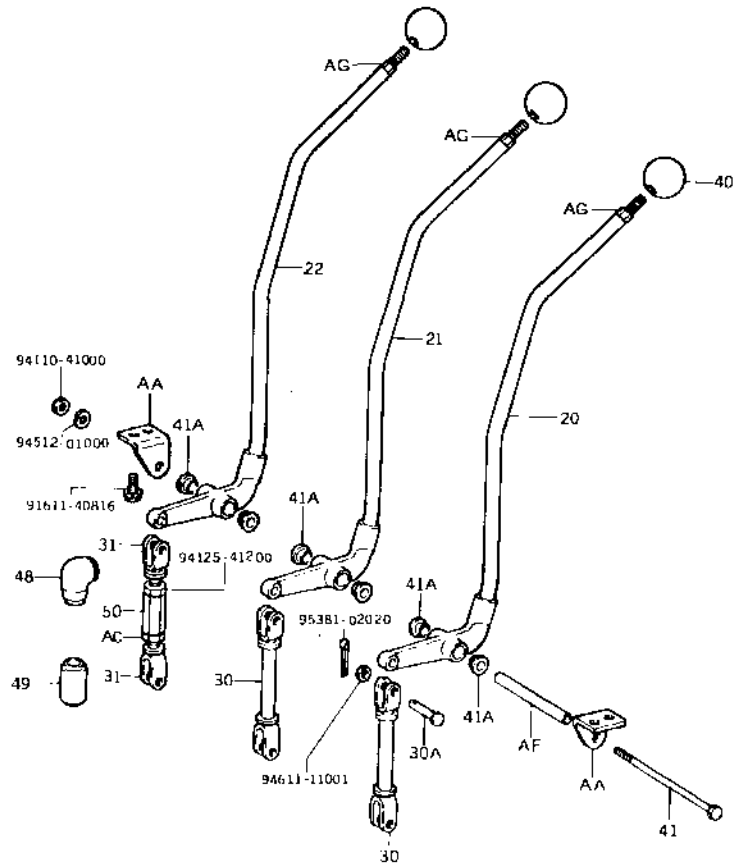

6709 017

FIG. 6709 OIL CONTROL VALVE LINK

**6709**

FV (4-WAY)

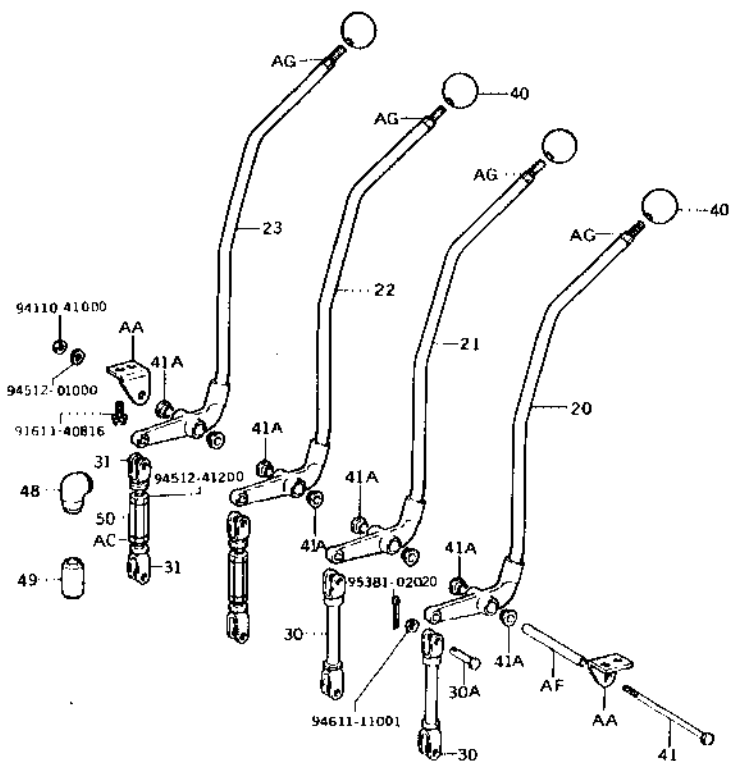

6709 D18

PART NAME CODE	PART NAME	QTY
6709-20	LEVER SUB-ASSY, CONTROL VALVE, NO.1	1
6709-21	LEVER SUB-ASSY, CONTROL VALVE, NO.2	1
6709-22	LEVER SUB-ASSY, CONTROL VALVE, NO.3	1
6709-23	LEVER SUB-ASSY, CONTROL VALVE, NO.4	1
6709-30	ROD SUB-ASSY, CONTROL VALVE LEVER, NO.1	1
6709-30A	PIN (FOR CONTROL VALVE LEVER ROD)	4
6709-31	ROD SUB-ASSY, CONTROL VALVE LEVER, NO.2	1
6709-40	KNOB, OIL CONTROL VALVE LEVER	2
6709-41	PIN, OIL CONTROL VALVE LEVER	1
6709-41A	BUSH (FOR LEVER PIN)	4
6709-48	BOOT, CONTROL VALVE LINK, NO.1	2
6709-49	BOOT, CONTROL VALVE LINK, NO.2	2
6709-50	TURBUCKLE	1
6709-AA	BRACKET SUB-ASSY	1
6709-AC	NUT	1
6709-AF	SPACER	1
6709-AG	BOLT, STUD	2

(FV ) ( 10)

G208



FIG. 6801 BODY PIPING

6801

FV

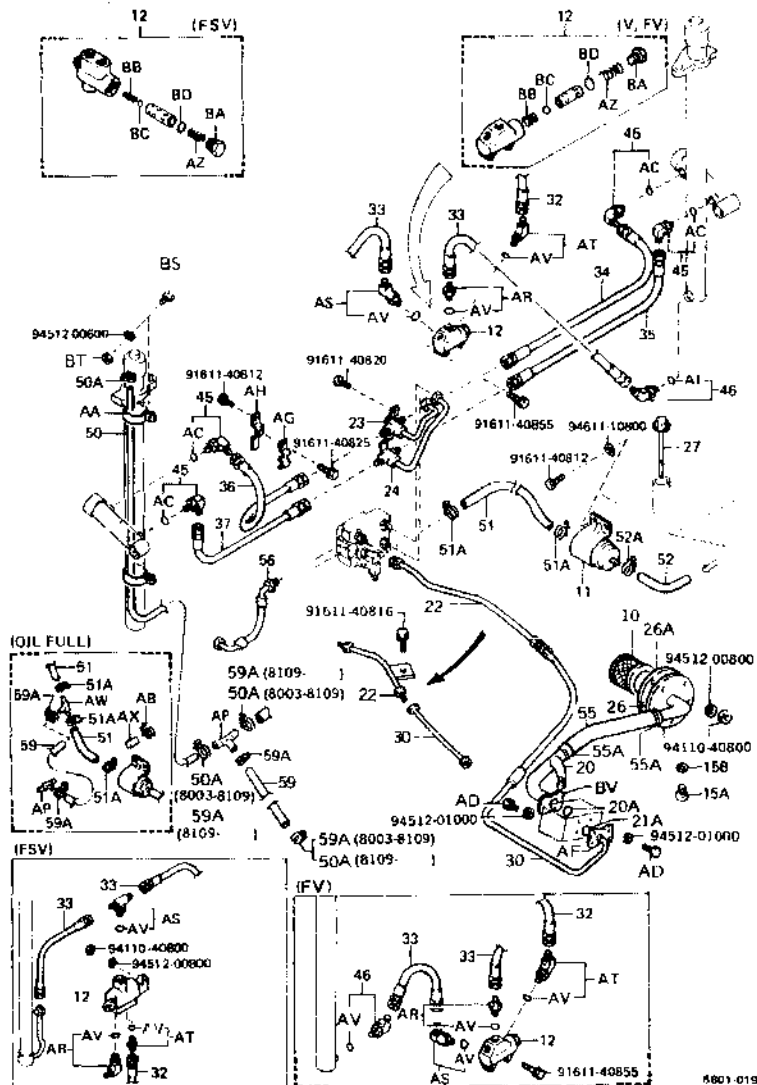

6801-019

PART NAME CODE	PART NAME	QTY
6801-10	FILTER ASSY, SUCTION	1
6801-11	FILTER ASSY, RETURN	1
6801-12	VALVE ASSY, FLOW REGULATOR	1
6801-15A	PLUG (FOR OIL TANK DRAIN)	1
6801-15B	GASKET (FOR OIL TANK DRAIN PLUG)	1
6801-20	PIPE SUB-ASSY (PUMP INLET)	1
6801-20A	RING, O (FOR OIL PUMP INLET)	1
6801-21A	RING, O (FOR OIL PUMP OUTLET)	1
6801-22	PIPE SUB-ASSY (PUMP TO VALVE)	1
6801-23	PIPE SUB-ASSY (TILT CYLINDER FRONT)	1
6801-24	PIPE SUB-ASSY (TILT CYLINDER REAR)	1
6801-26	OUTLET SUB-ASSY, OIL TANK	1
6801-26A	PACKING, OIL TANK COVER	1
6801-27	CAP SUB-ASSY, OIL TANK	1
6801-30	HOSE, HIGH PRESSURE, NO.1 (PUMP TO VALVE)	1
6801-32	HOSE, HIGH PRESSURE, NO.1 (VALVE TO LIFT)	1
6801-33	HOSE, HIGH PRESSURE, NO.2 (VALVE TO LIFT)	1
6801-34	HOSE, HIGH PRESSURE, NO.1 (TILT FRONT)	1
6801-35	HOSE, HIGH PRESSURE, NO.1 (TILT REAR)	1
6801-36	HOSE, HIGH PRESSURE, NO.2 (TILT FRONT)	1
6801-37	HOSE, HIGH PRESSURE, NO.2 (TILT REAR)	1
6801-45	FITTING (FOR TILT CYLINDER)	2
6801-46	FITTING (FOR LIFT CYLINDER)	1
6801-51	HOSE, LOW PRESSURE, NO.1 (VALVE TO TANK)	1
6801-51A	CLAMP (FOR VALVE TO TANK NO.1 HOSE)	2
6801-52	HOSE, LOW PRESSURE, NO.2 (VALVE TO TANK)	1
6801-52A	CLAMP (FOR VALVE TO TANK NO.2 HOSE)	2
6801-55	HOSE, LOW PRESSURE (TANK TO PUMP)	1
6801-55A	CLAMP (FOR TANK TO PUMP HOSE)	2
6801-56	HOSE, LOW PRESSURE (STEERING TO VALVE)	1
6801-AC	RING, O	4
6801-AD	BOLT	8
6801-AF	FLANGE, SPLIT	1
6801-AG	CLAMP	1
6801-AH	BRACKET SUB-ASSY, TILT HOSE	1
6801-AI	RING, O	1
6801-AR	FITTING	1
6801-AS	FITTING	1
6801-AT	FITTING	1
6801-AV	RING, O	3
6801-AZ	SPRING, COMPRESSION	1
6801-BA	PLUG	1
6801-BB	SPRING, COMPRESSION	1
6801-BC	BALL, STEEL	1
6801-BD	RING, O	1
6801-BS	BOLT	5
6801-BT	WASHER	5
6801-BV	FLANGE	2

(FV) ( 11)

G208

FIG. 6802 MAST PIPING

**6802**

FV

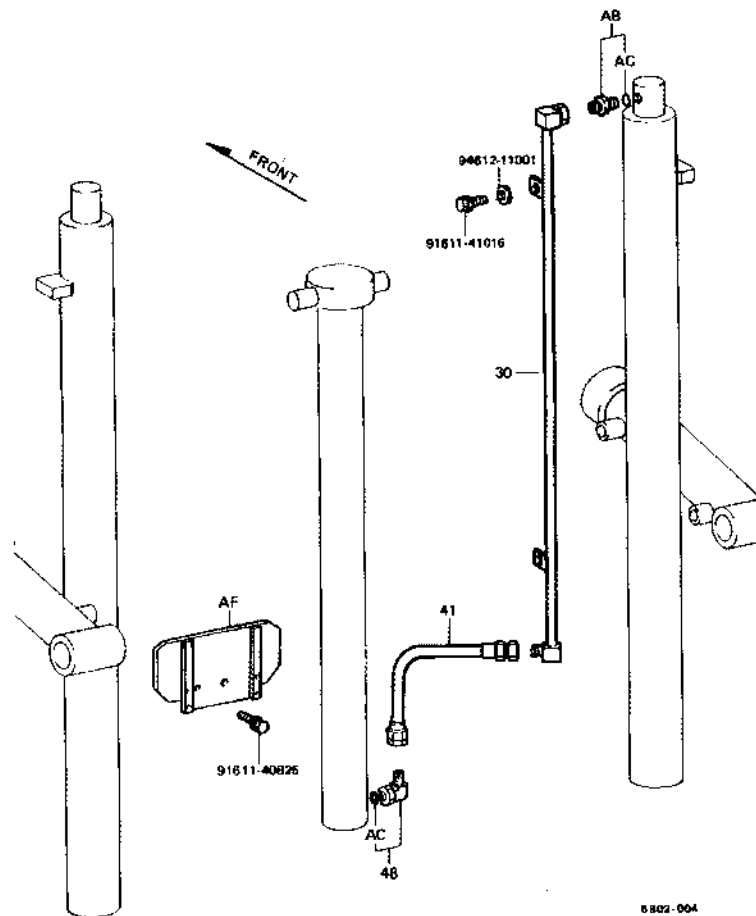

PART NAME CODE	PART NAME	QTY
6802-30	PIPE SUB-ASSY, NO.1 (FRONT LIFT) -----	1
6802-41	HOSE, HIGH PRESSURE, NO.1 (FRONT LIFT) -----	1
6802-48	FITTING (FOR FRONT LIFT CYLINDER) -----	1
6802-AB	FITTING -----	1
6802-AC	RING, O -----	2
6802-AF	GUARD SUB-ASSY, HOSE -----	1

FIG. 6101 MAST

# 6101

M

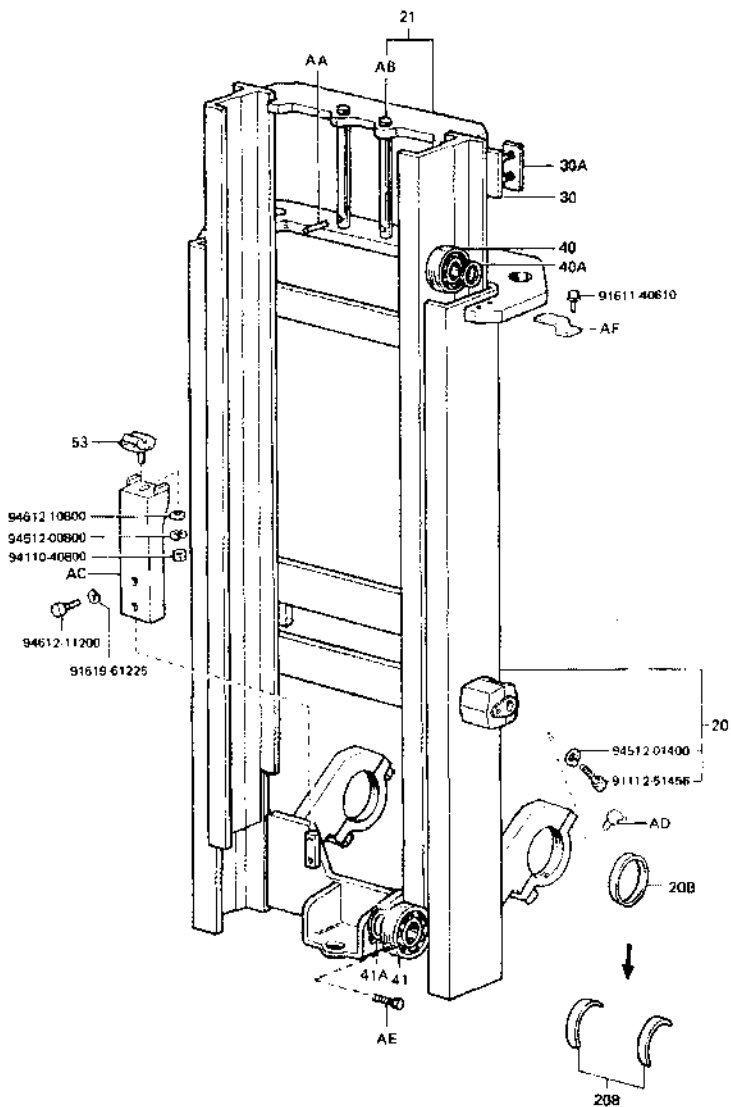

PART NAME CODE	PART NAME	QTY
6101-20	MAST SUB-ASSY, OUTER -----	1
6101-20B	BUSH, MAST SUPPORT -----	1
6101-21	MAST SUB-ASSY, INNER -----	1
6101-30	STRIP SUB-ASSY, OUTER MAST -----	2
6101-30A	SHIM, OUTER MAST STRIP -----	99
6101-40	ROLLER, LIFT (FOR OUTER MAST) -----	2
6101-40A	SHIM, LIFT ROLLER (FOR OUTER MAST) -----	99
6101-41	ROLLER, LIFT (FOR INNER MAST) -----	2
6101-41A	SHIM, LIFT ROLLER (FOR INNER MAST) -----	99
6101-53	CUSHION, MAST (FOR INNER MAST) -----	2
6101-AA	PIN, SPRING -----	2
6101-AB	GUIDE, CHAIN WHEEL SUPPORT -----	2
6101-AC	STOPPER, INNER MAST -----	2
6101-AD	FITTING, GREASE -----	2
6101-AE	BOLT, STOPPER -----	2
6101-AF	COVER, ROLLER -----	2

6101-065

(M) ( 1)

G208

FIG. 6301 LIFT BRACKET & FORK

**6301**

M

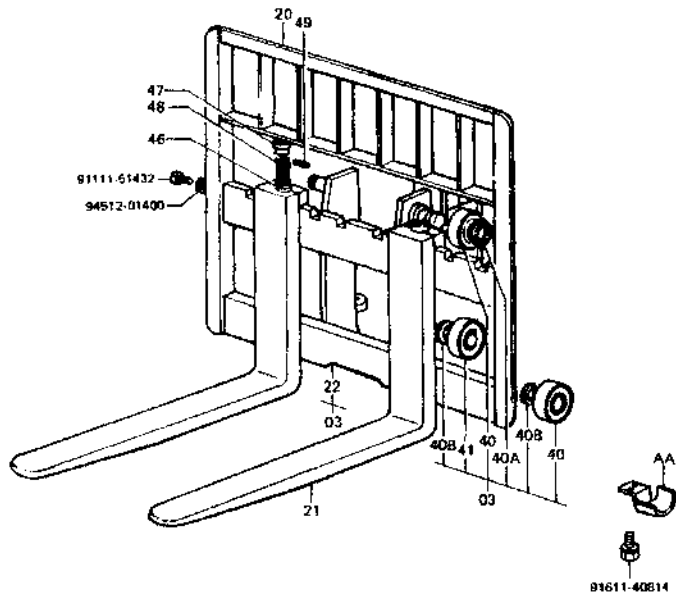

6301 005

PART NAME CODE	PART NAME	QTY
6301-03	BRACKET ASSY, LIFT -----	1
6301-20	BACKREST SUB-ASSY -----	1
6301-21	FORK SUB-ASSY -----	2
6301-22	BRACKET SUB-ASSY, LIFT -----	1
6301-40	ROLLER, LIFT (UPPER, LOWER) -----	4
6301-40A	RING, SHAFT SNAP (UPPER, LOWER) -----	2
6301-40B	SHIM, LIFT ROLLER -----	99
6301-41	ROLLER, LIFT (CENTER) -----	2
6301-46	PIN, FORK STOPPER -----	2
6301-47	KNDB, FORK STOPPER PIN -----	2
6301-48	SPRING, FORK STOPPER PIN -----	2
6301-49	PIN, SPRING (FOR FORK STOPPER PIN) -----	2
6301-AA	COVER, LIFT BRACKET ROLLER -----	4

FIG. 6302 CHAIN & CHAIN WHEEL

**6302**

M

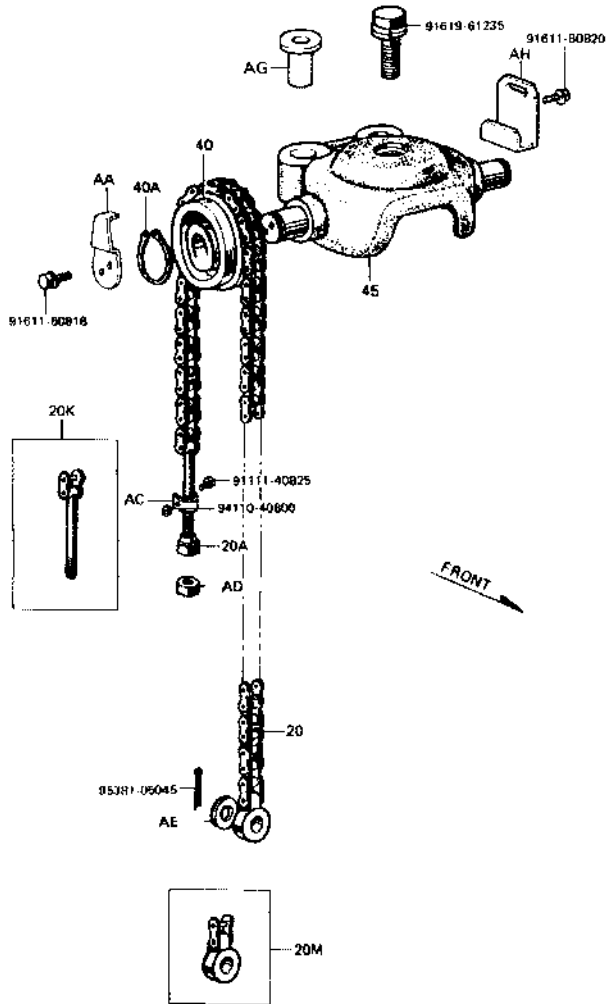

PART NAME CODE	PART NAME	QTY
6302-20	CHAIN SUB-ASSY -----	2
6302-20A	NUT, CHAIN ADJUST -----	2
6302-20K	BOLT KIT, CHAIN ANCHOR, NO.1 -----	2
6302-20M	BOLT KIT, CHAIN EYE -----	2
6302-40	WHEEL, CHAIN -----	2
6302-40A	RING, SHAFT SNAP (FOR CHAIN WHEEL) -----	2
6302-45	SUPPORT, CHAIN WHEEL -----	1
6302-AA	PLATE, CHAIN STOPPER -----	1
6302-AC	CLAMP, CHAIN ANCHOR BOLT -----	2
6302-AD	NUT, HEXAGON -----	2
6302-AE	WASHER, CHAIN SPECIAL -----	2
6302-AG	BUSHING -----	2
6302-AH	COVER, CHAIN WHEEL -----	2

6302-045

(M) ( 3 )

G208

FIG. 6504 LIFT CYLINDER

6504

M "H2000-H4000"

M "4500-H5000"

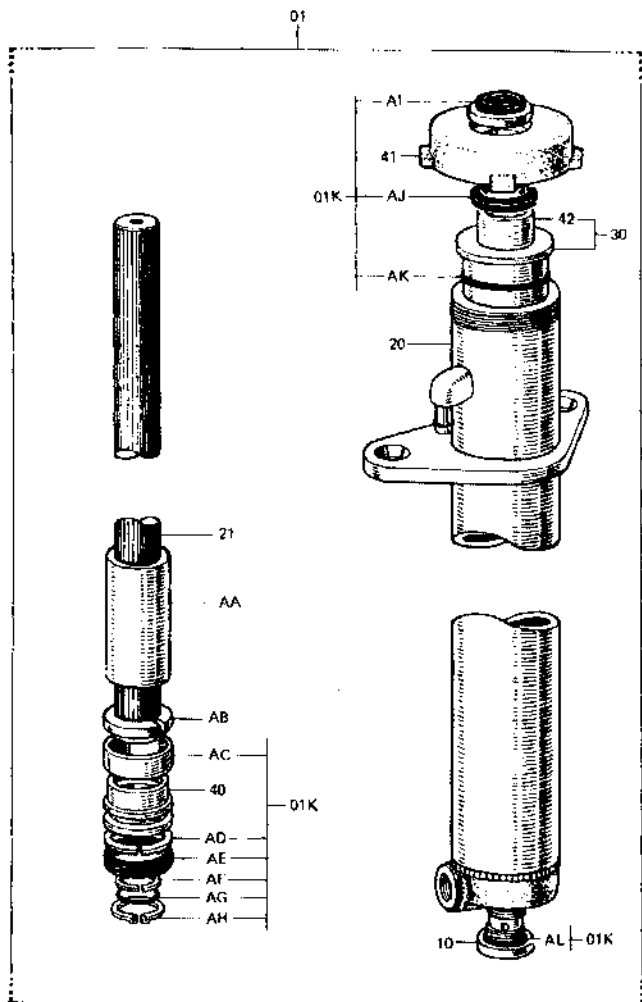

6504 001

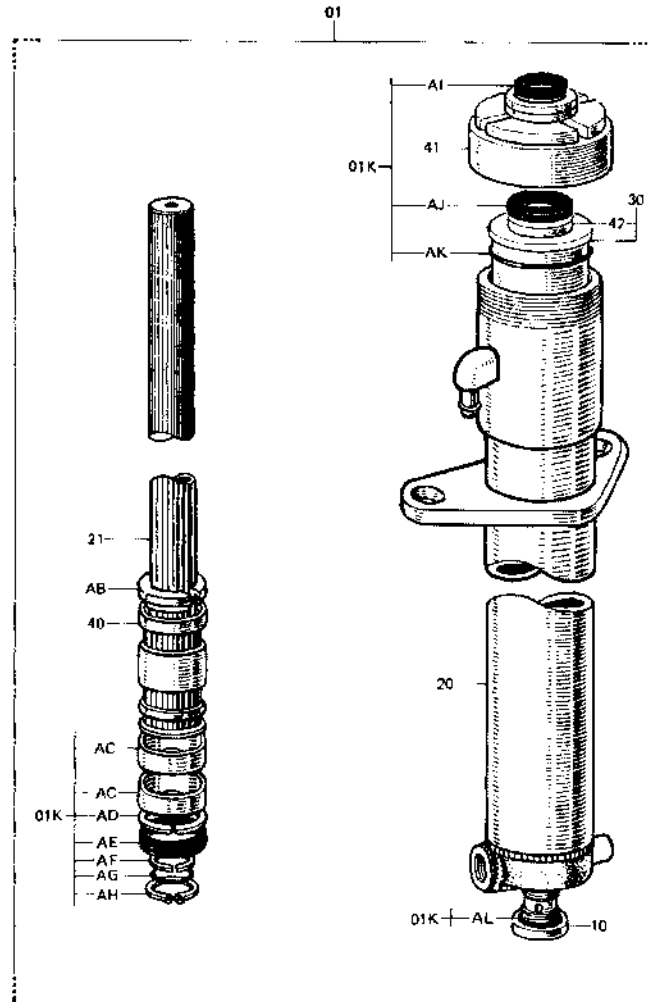

6504 007

**6504**

PART NAME CODE	PART NAME	QTY
6504-01	CYLINDER ASSY, LIFT -----	1
6504-01K	CYLINDER O/H KIT, LIFT -----	1
6504-10	VALVE ASSY, FLOW REGULATOR -----	1
6504-20	CYLINDER SUB-ASSY, LIFT -----	1
6504-21	ROD SUB-ASSY, LIFT CYLINDER PISTON -----	1
6504-30	GUIDE SUB-ASSY, LIFT CYLINDER ROD -----	1
6504-40	PISTON, LIFT CYLINDER -----	1
6504-41	COVER, LIFT CYLINDER -----	1
6504-42	SLEEVE, LIFT CYLINDER ROD GUIDE -----	1
6504-AA	SPACER, LIFT CYLINDER -----	1
6504-AB	RING, STOPPER -----	1
6504-AC	RING, WEAR -----	1- 2
6504-AD	RING, BACK UP -----	1
6504-AE	PACKING, U -----	1
6504-AF	RING, BACK UP -----	1
6504-AG	RING, O -----	1
6504-AH	RING, SHAFT SNAP -----	1
6504-AI	SEAL, DUST -----	1
6504-AJ	PACKING, U -----	1
6504-AK	RING, O -----	1
6504-AL	RING, O -----	1

(M ) ( 4 )

G208

FIG. 6511 TILT CYLINDER

6511

M

M

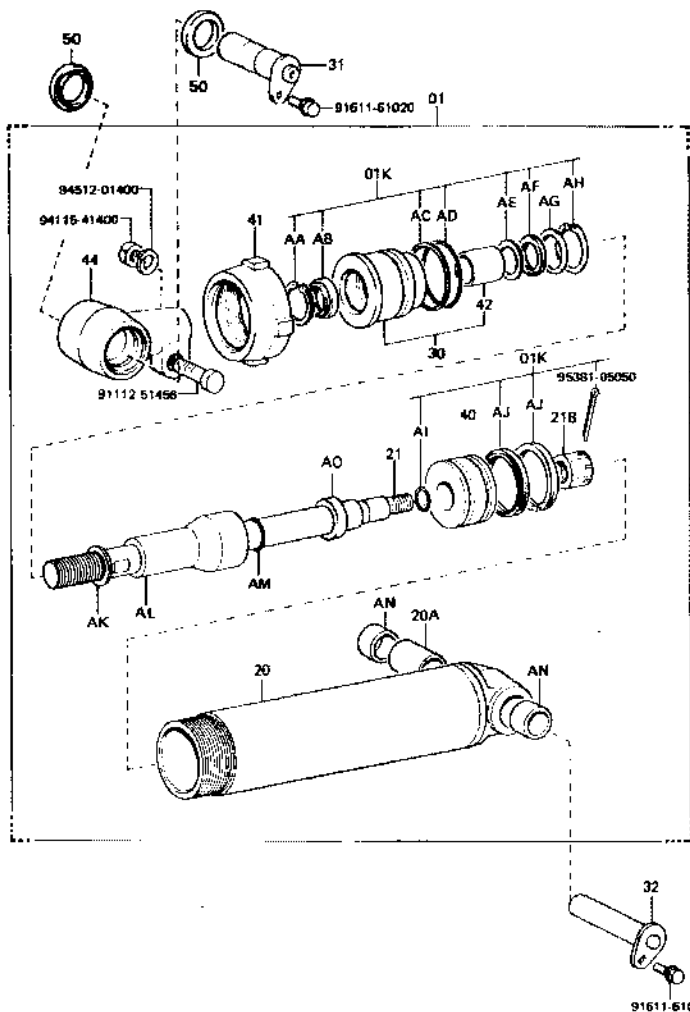

6511-010

テイルト角度表  
TABLE OF TILT RANGE

生産期間 PROD DATE	型式 MODELS	タイヤ TIRE	揚 高 LIFTING HEIGHT	備 考 DESCRIPTION	テイルト角 TILT RANGE
8003	F, FV, M, SV, V	SINGLE	H2000-H4000		8D - 12D
8003-	F, FV, M, SV, V	DOUBLE	H2000-H4500		6D - 12D
8003-	F, FV, M, SV, V	SINGLE	H4500-H5000		8D 6D
8003	F, FV, M, SV, V	DOUBLE	H5000		6D - 6D
8003-	F, FV, M, SV, V		H2000	FRONT GLASS	8D - 10D
8003-	FSV, FS		H3700-H4700	DOMESTIC	6D - 6D
8003-	FSV, FS		H5000-H6500	DOMESTIC	3D - 6D
8003-	FSV, FS		H3700-H6500	EXPORT	8D - 6D
8003-	F, FV, M, SV, V	SINGLE	H2000-H4000	AUSTRALIA	3D - 12D
8003-	F, FV, M, SV, V	DOUBLE	H2000-H4500	AUSTRALIA	3D - 12D
8003-	F, FV, M, SV, V	SINGLE	H4500-H5000	AUSTRALIA	3D - 8D
8003-	F, FV, M, SV, V	DOUBLE	H5000	AUSTRALIA	3D - 8D
8003-	F, FV, M, SV, V		H2000	FRONT GLASS AUSTRALIA	3D - 6D
8003-	FV, M, SV, V		H3700-H6500	AUSTRALIA	3D - 6D

8511-018



FIG. 6511 TILT CYLINDER

**6511**

M

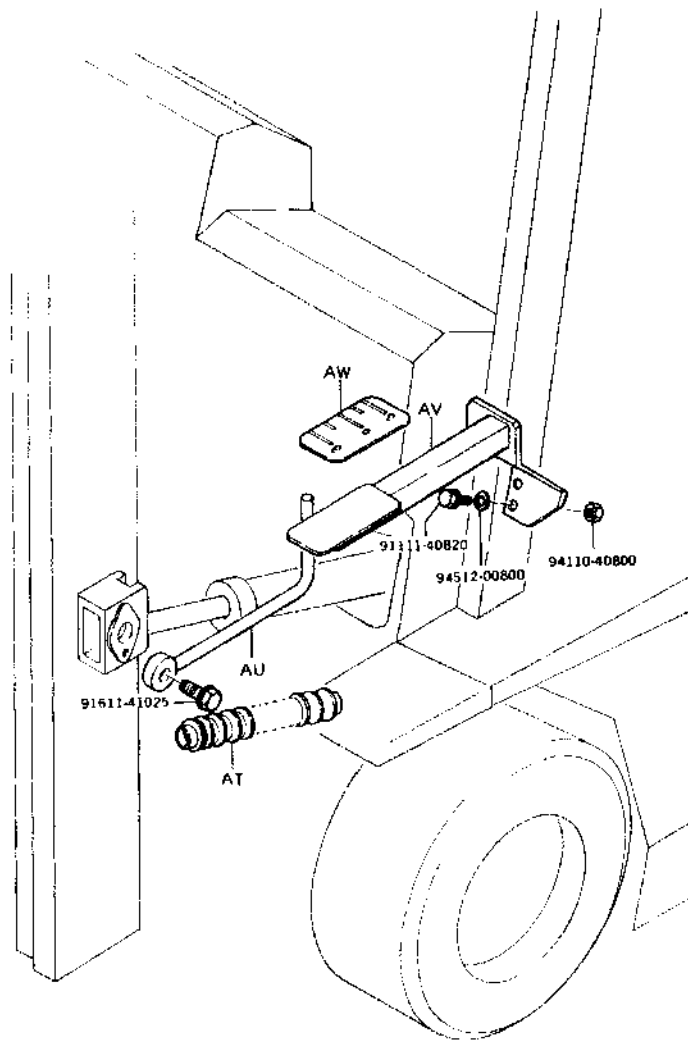

5511-013

PART NAME CODE	PART NAME	QTY
6511-01	CYLINDER ASSY, TILT -----	2
6511-01K	CYLINDER O/H KIT, TILT -----	2
6511-20	CYLINDER SUB-ASSY, TILT -----	2
6511-20A	BUSH, PIN (FOR CYLINDER) -----	2
6511-21	ROD SUB-ASSY, TILT CYLINDER PISTON -----	2
6511-218	NUT, CASTLE -----	2
6511-30	GUIDE SUB-ASSY, TILT CYLINDER ROD -----	2
6511-31	PIN SUB-ASSY, TILT CYLINDER, FR -----	2
6511-32	PIN SUB-ASSY, TILT CYLINDER, RR -----	2
6511-40	PISTON, TILT CYLINDER -----	2
6511-41	COVER, TILT CYLINDER -----	2
6511-42	SLEEVE, TILT CYLINDER ROD GUIDE -----	2
6511-44	JOINT, PISTON ROD -----	2
6511-50	SEAL, GREASE -----	4
6511-AA	RING, HOLE SNAP -----	2
6511-AB	SEAL, DUST -----	2
6511-AC	RING, BACK UP -----	2
6511-AD	RING, O -----	2
6511-AE	RING, BACK UP -----	2
6511-AF	PACKING, U -----	2
6511-AG	PLATE, STOPPER -----	2
6511-AH	RING, HOLE SNAP -----	2
6511-AI	RING, O -----	2
6511-AJ	PACKING, U -----	4
6511-AK	SHIM, TILT CONTROL -----	99
6511-AL	SPACER, TILT CONTROL -----	2
6511-AM	RING, O -----	4
6511-AN	COLLAR -----	4
6511-AD	SPACER, TILT CONTROL -----	2
6511-AT	BOOT SUB-ASSY -----	2
6511-AU	BAR SUB-ASSY, TILT GAUGE -----	1
6511-AV	BRACKET SUB-ASSY, TILT GAUGE -----	1
6511-AW	PLATE, TILT CYLINDER INDICATOR -----	1

( M ) ( 5 )

G208

FIG. 6701 OIL PUMP

**6701**

M

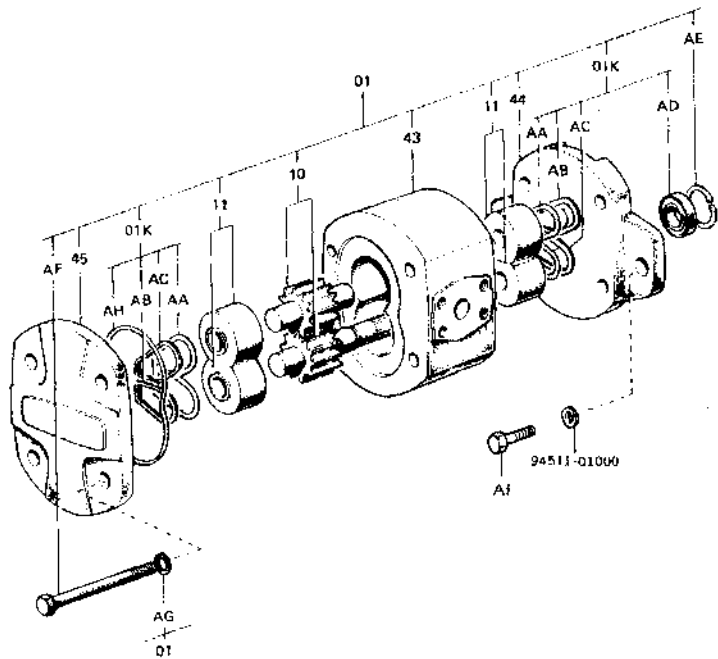

PART NAME CODE	PART NAME	QTY
6701-01	PUMP ASSY, OIL -----	1
6701-01K	PUMP O/H KIT, OIL -----	1
6701-10	GEAR SET -----	1
6701-11	BUSH SET, NO.1 -----	2
6701-43	BOOY -----	1
6701-44	FLANGE, MOUNTING -----	1
6701-45	COVER -----	1
6701-AA	SEAL, BUSHING -----	2
6701-AB	RING, BACKING, RH -----	2
6701-AC	RING, BACKING, LH -----	2
6701-AD	SEAL, OIL -----	1
6701-AE	RING, SNAP -----	1
6701-AF	BOLT -----	4
6701-AG	WASHER, SPRING -----	4
6701-AH	SEAL, BOOY -----	2
6701-AI	BOLT -----	2

6701 013

FIG. 6705 OIL CONTROL VALVE

6705

M (UL)

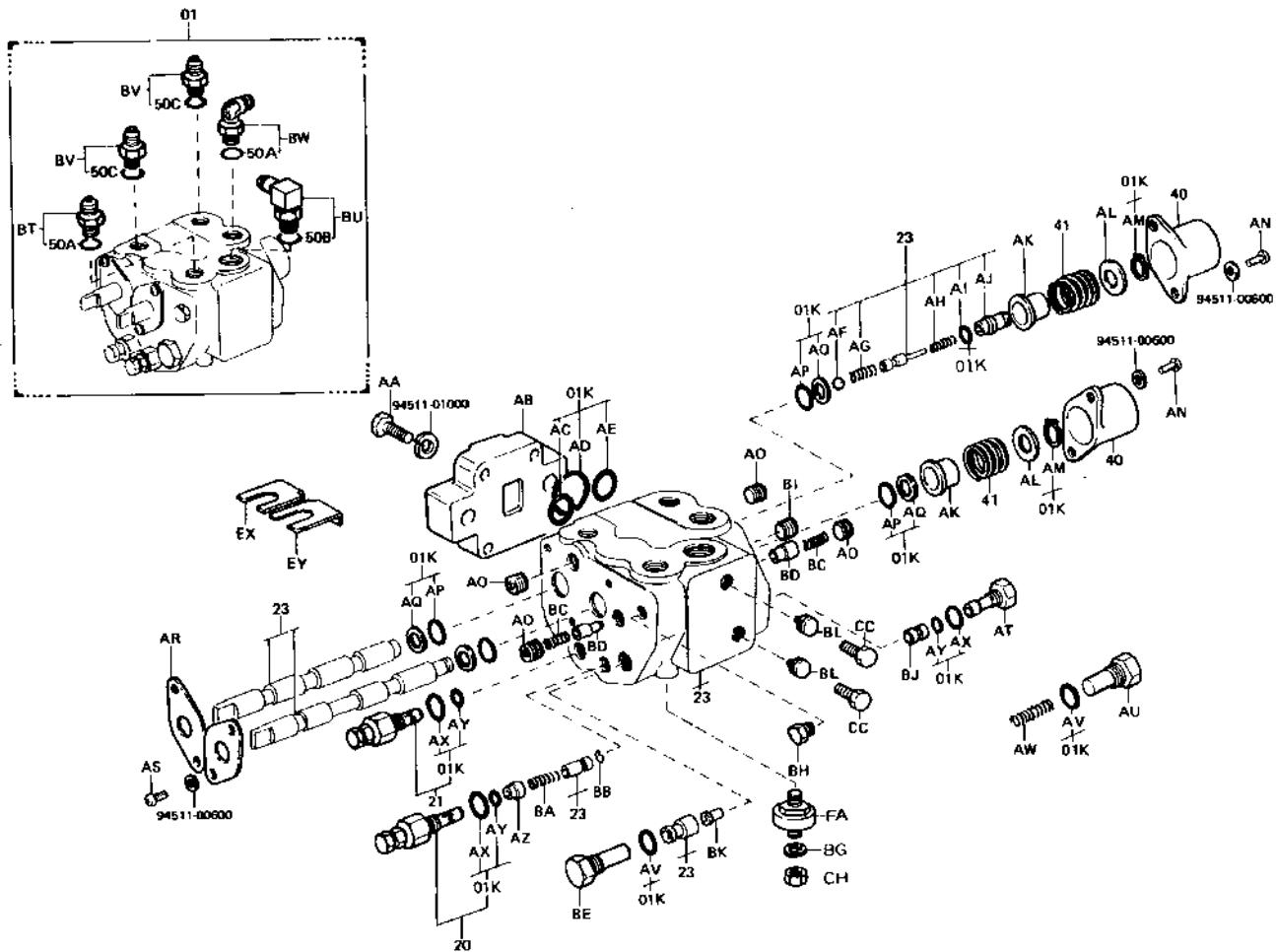





FIG. 6705 OIL CONTROL VALVE

6705

M (3-WAY)

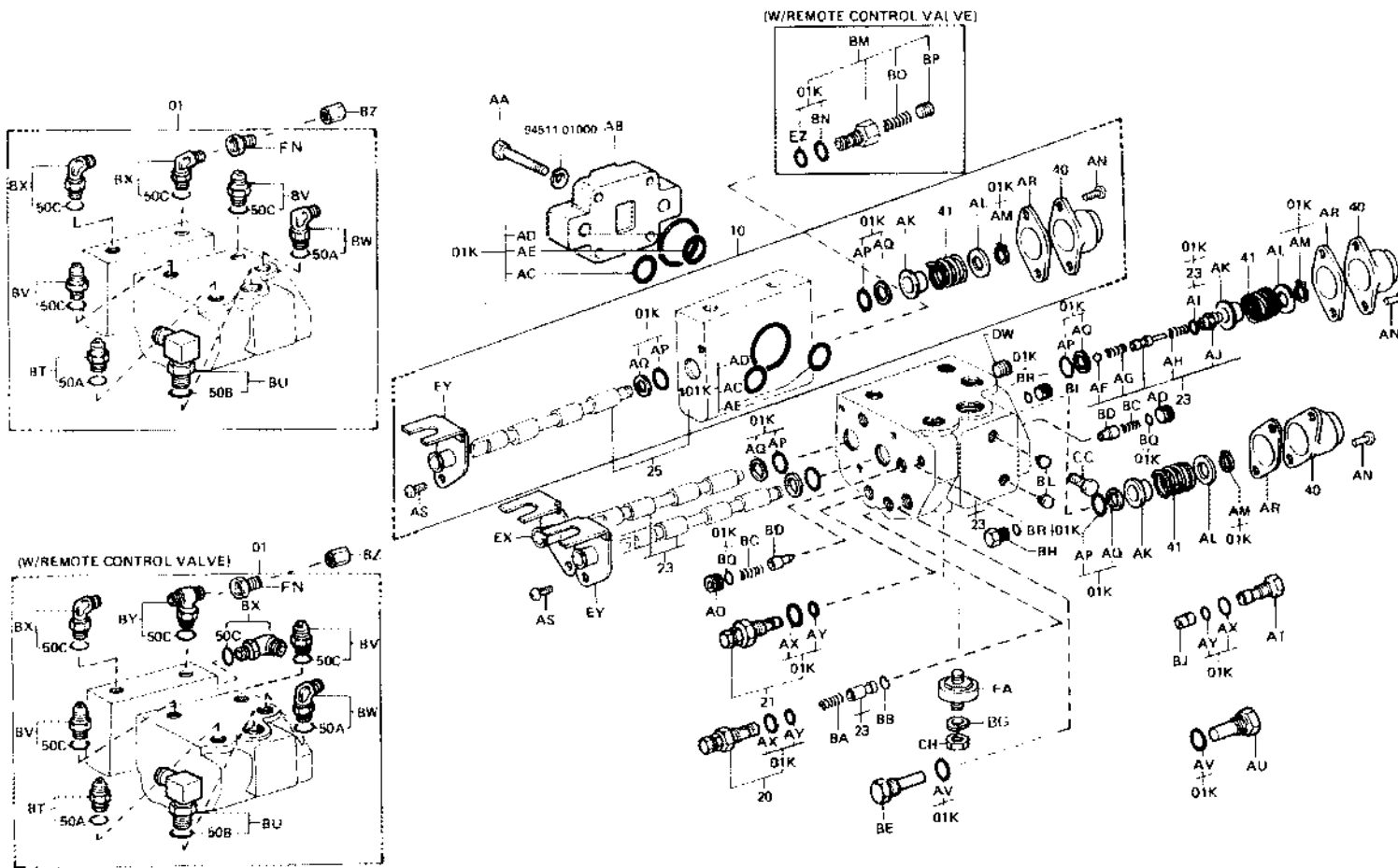
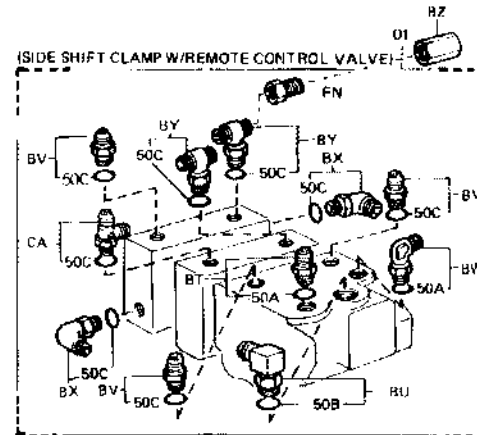
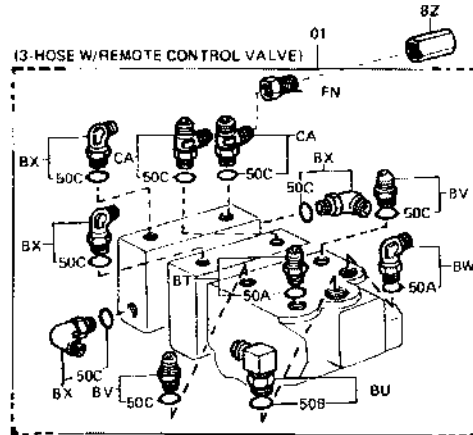
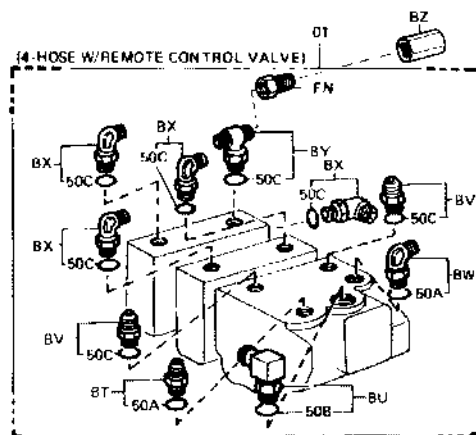
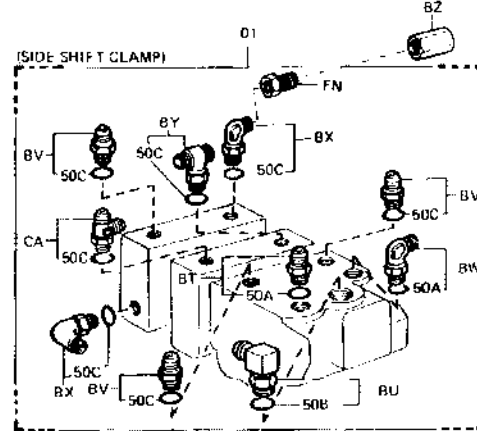
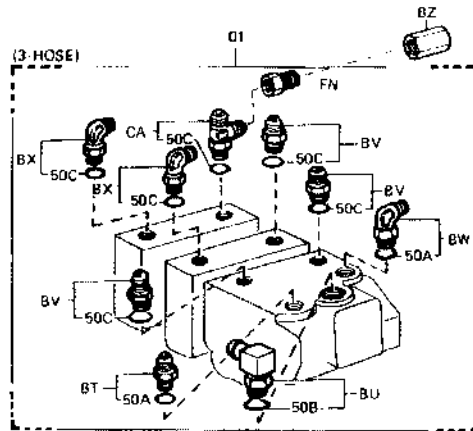
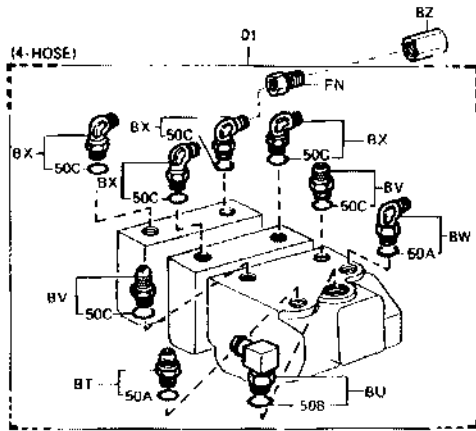

FIG. 6705 OIL CONTROL VALVE

6705

M (4-WAY)



6705-05B



FIG. 6705 OIL CONTROL VALVE

6705

M 4-WAY..UL)

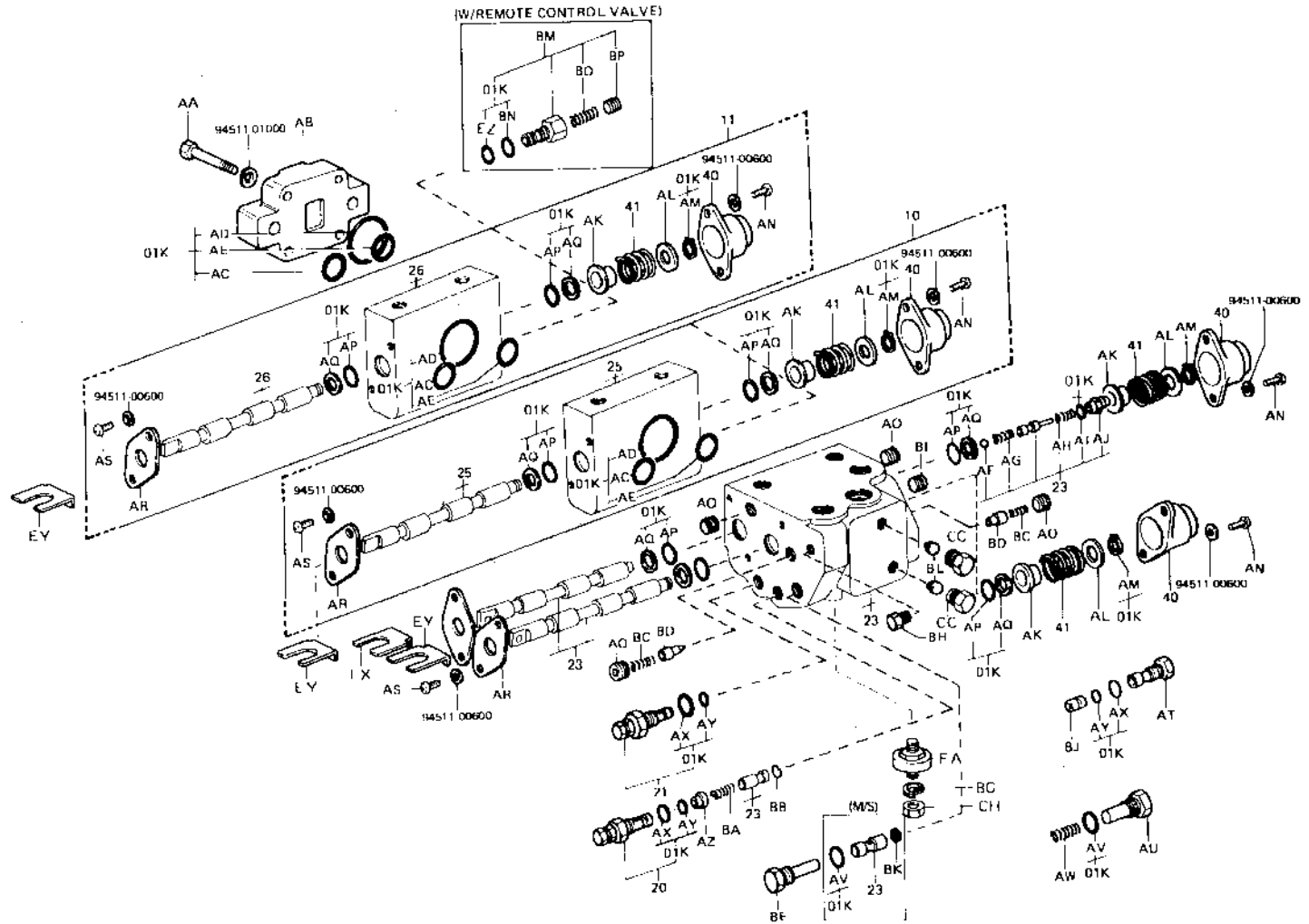
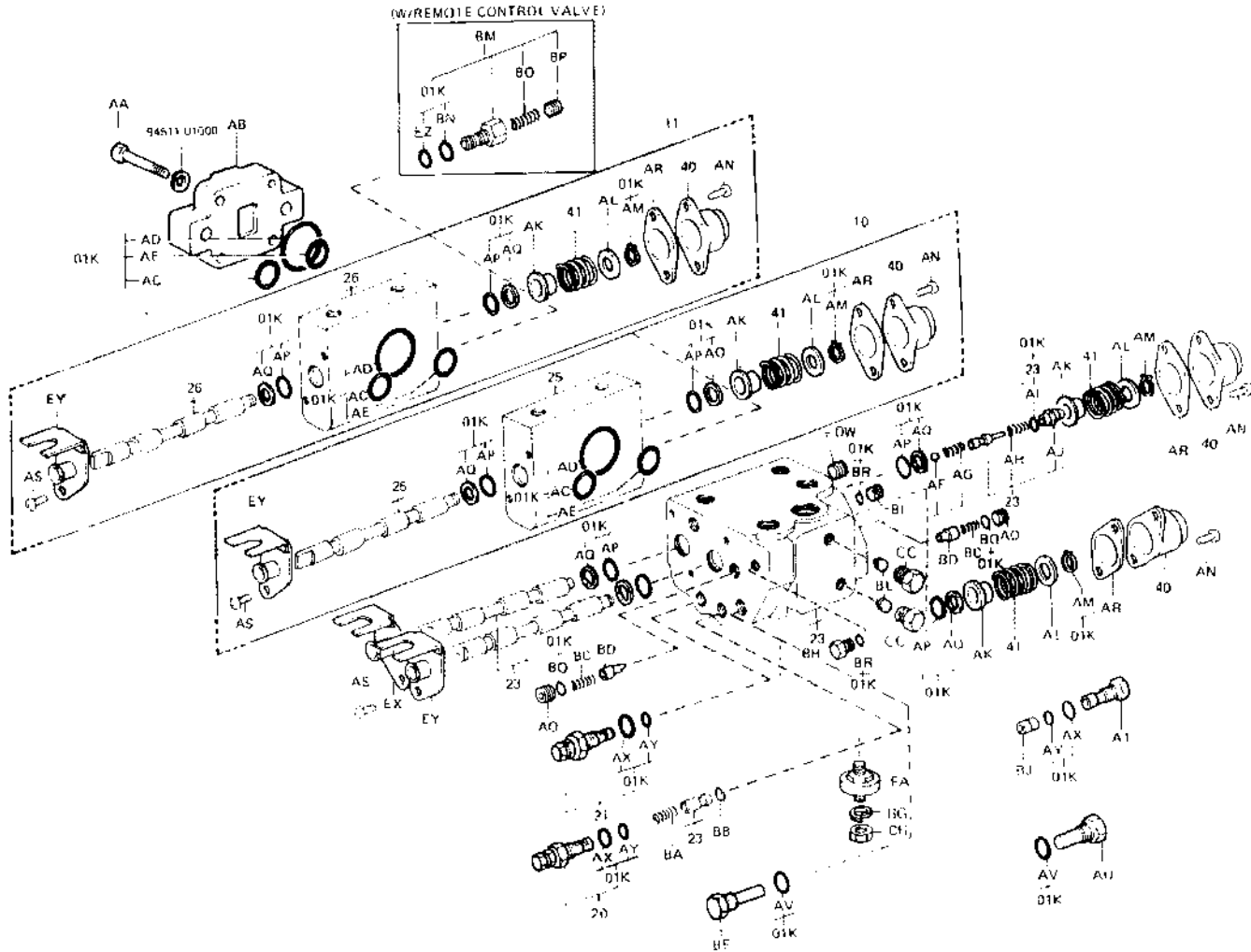



FIG. 6705 OIL CONTROL VALVE

6705

M (4-WAY)



# 6705

PART NAME CODE	PART NAME	QTY
6705-01	VALVE ASSY, OIL CONTROL -----	1
6705-01K	VALVE O/H KIT, OIL CONTROL -----	1
6705-10	VALVE ASSY, PLUNGER SECTION, NO.1 -----	1
6705-11	VALVE ASSY, PLUNGER SECTION, NO.2 -----	1
6705-20	VALVE SET, PILOT RELIEF, NO.1 -----	1
6705-21	VALVE SET, PILOT RELIEF, NO.2 -----	1
6705-23	HOUSING & SPOOL SET, NO.1 -----	1
6705-25	HOUSING & SPOOL SET, ATTACHMENT, NO.1 -----	1
6705-26	HOUSING & SPOOL SET, ATTACHMENT, NO.2 -----	1
6705-40	COVER, SPRING -----	2
6705-41	SPRING, COMPRESSION (FOR SPOOL RETURN) -----	2
6705-50A	RING, O, NO.1 (FOR VALVE FITTING) -----	2
6705-50B	RING, O, NO.2 (FOR VALVE FITTING) -----	1
6705-50C	RING, O, NO.3 (FOR VALVE FITTING) -----	2
6705-AA	BOLT -----	4
6705-AB	HOUSING, OUTLET -----	1
6705-AC	RING, O -----	1
6705-AD	RING, O -----	1
6705-AE	RING, O -----	1
6705-AF	BALL, STEEL -----	1
6705-AG	SPRING -----	1
6705-AH	SPRING, COMPRESSION -----	1
6705-AI	RING, O -----	1
6705-AJ	STOPPER -----	1
6705-AK	HOLDER, SPRING -----	2
6705-AL	WASHER, PLATE -----	2
6705-AM	RING, SHAFT SNAP -----	2
6705-AN	SCREW -----	4
6705-AO	PLUG -----	2
6705-AP	RING, O -----	4
6705-AQ	RING, BACK UP -----	4
6705-AR	HOLDER, SEAL -----	2
6705-AS	SCREW -----	4
6705-AT	STOPPER -----	1
6705-AU	STOPPER -----	1
6705-AV	RING, O -----	2
6705-AW	SPRING, COMPRESSION -----	1
6705-AX	RING, O -----	3
6705-AY	RING, O -----	3
6705-AZ	COLLAR -----	1
6705-BA	SPRING, COMPRESSION -----	1
6705-BB	WIRE, ORIFICE TURNING -----	1
6705-BC	SPRING, COMPRESSION -----	2
6705-BD	PLUNGER, CHECK -----	2
6705-BE	STOPPER -----	1
6705-BG	WASHER -----	4
6705-BH	PLUG -----	1
6705-BI	PLUG -----	1
6705-BJ	SEAT, VALVE -----	1
6705-BK	VALVE, CHECK -----	1
6705-BL	SEAT, INSERT -----	2
6705-BM	VALVE SUB-ASSY, RELIEF -----	1
6705-BN	RING, O -----	1

(M) ( 7 ) G208

PART NAME CODE	PART NAME	QTY
6705-B0	SPRING -----	1
6705-BP	STOPPER -----	1
6705-BQ	RING, O -----	2
6705-BR	RING, O -----	2
6705-BT	FITTING -----	1
6705-BU	FITTING -----	1
6705-BV	FITTING -----	2
6705-BW	FITTING -----	1
6705-BX	FITTING -----	2
6705-BY	FITTING -----	1
6705-BZ	PLUG -----	2
6705-CA	FITTING -----	1
6705-CC	PLUG -----	2
6705-CH	NUT -----	4
6705-CN	PLUG -----	1
6705-EX	BRACKET SUB-ASSY, TILT -----	1
6705-EY	BRACKET SUB-ASSY, LIFT -----	1
6705-EZ	RING, O -----	1
6705-FA	INSULATOR -----	4
6705-FN	FITTING -----	2

(M) ( 8 ) G208

FIG. 6709 OIL CONTROL VALVE LINK

6709

M

M (3-WAY)

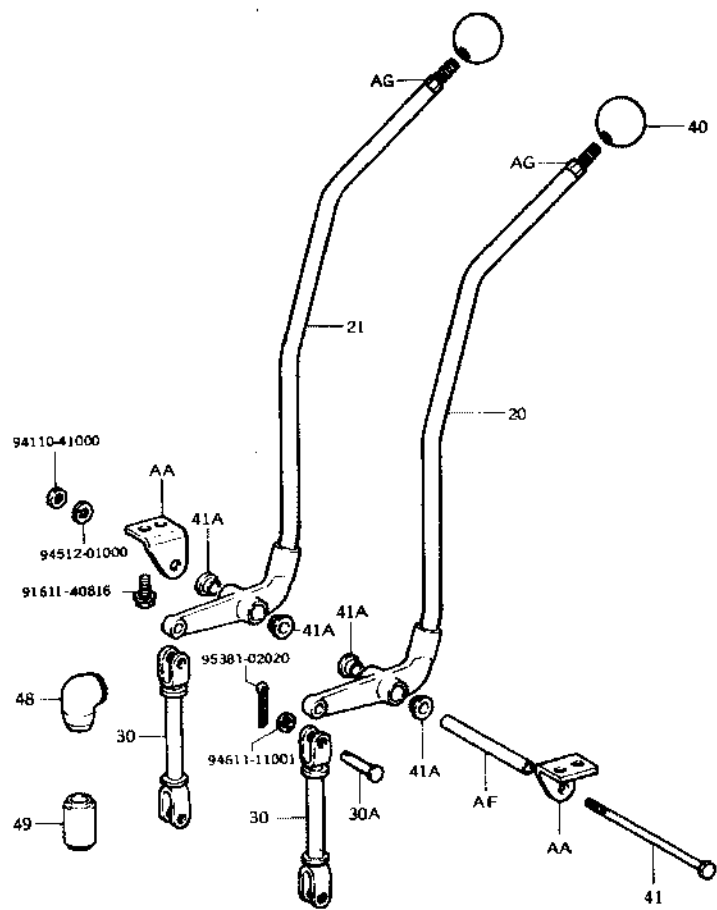

6709-016

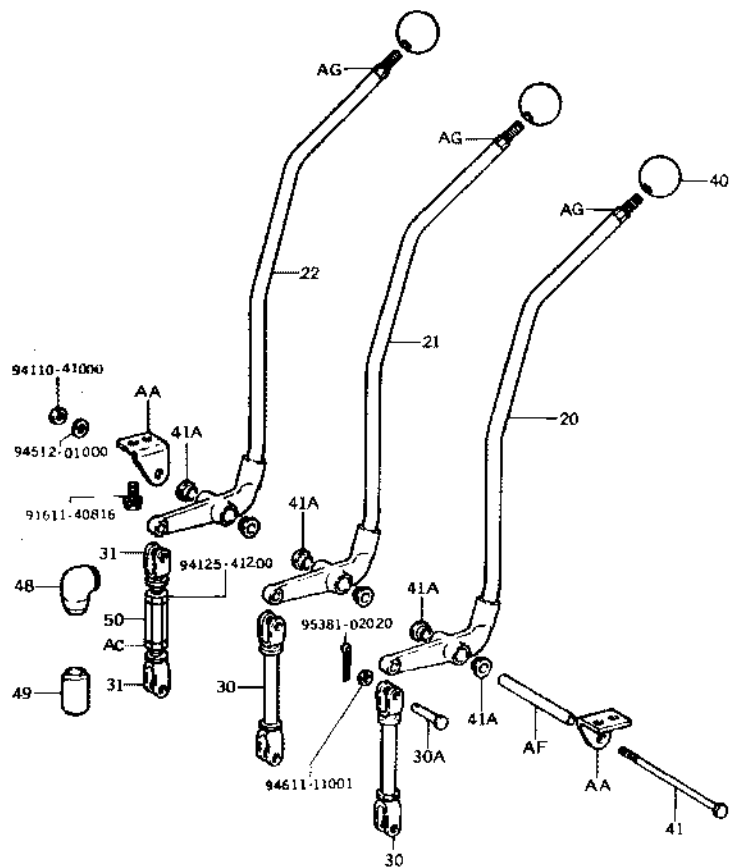

6709-017



FIG. 6709 OIL CONTROL VALVE LINK

**6709**

M (4-WAY)

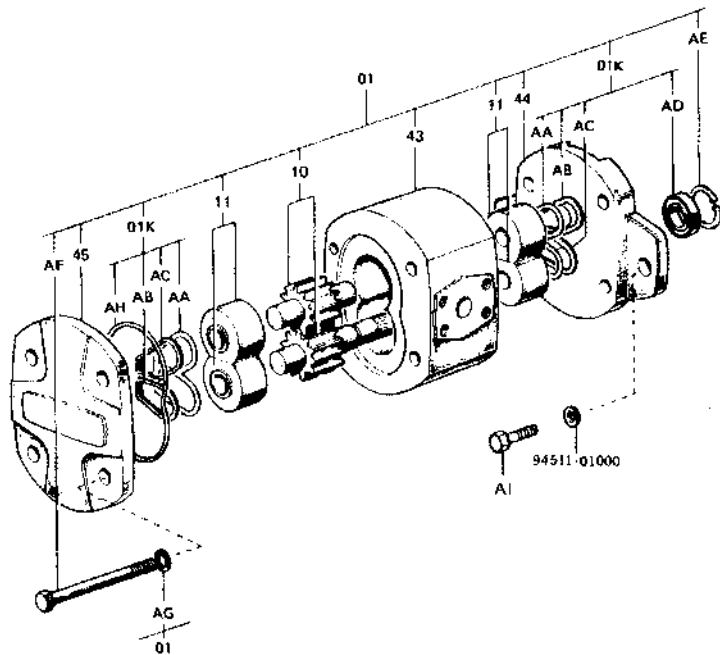

PART NAME CODE	PART NAME	QTY
6709-20	LEVER SUB-ASSY, CONTROL VALVE, NO.1 -----	1
6709-21	LEVER SUB-ASSY, CONTROL VALVE, NO.2 -----	1
6709-22	LEVER SUB-ASSY, CONTROL VALVE, NO.3 -----	1
6709-23	LEVER SUB-ASSY, CONTROL VALVE, NO.4 -----	1
6709-30	ROD SUB-ASSY, CONTROL VALVE LEVER, NO.1 -----	1
6709-30A	PIN (FOR CONTROL VALVE LEVER ROD) -----	4
6709-31	ROD SUB-ASSY, CONTROL VALVE LEVER, NO.2 -----	1
6709-40	KNOB, OIL CONTROL VALVE LEVER -----	2
6709-41	PIN, OIL CONTROL VALVE LEVER -----	1
6709-41A	BUSH (FOR LEVER PIN) -----	4
6709-48	BOOT, CONTROL VALVE LINK, NO.1 -----	2
6709-49	BOOT, CONTROL VALVE LINK, NO.2 -----	2
6709-50	TURNBUCKLE -----	1
6709-AA	BRACKET SUB-ASSY -----	1
6709-AC	NUT -----	1
6709-AF	SPACER -----	1
6709-AG	BOLT, STUD -----	2

6701-01B

(M) ( 9)

G208



FIG. 6101 MAST

**6101**

SV

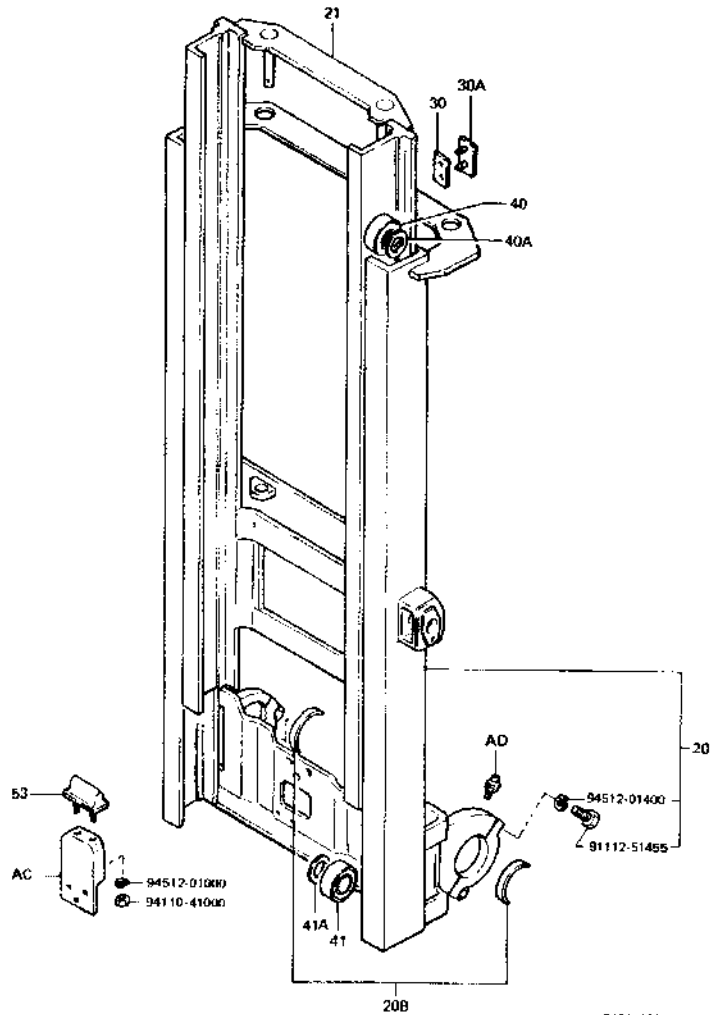

PART NAME CODE	PART NAME	QTY
6101-20	MAST SUB-ASSY, OUTER -----	1
6101-20B	BUSH, MAST SUPPORT -----	1
6101-21	MAST SUB-ASSY, INNER -----	1
6101-30	STRIP SUB-ASSY, OUTER MAST -----	2
6101-30A	SHIM, OUTER MAST STRIP -----	99
6101-40	ROLLER, LIFT (FOR OUTER MAST) -----	2
6101-40A	SHIM, LIFT ROLLER (FOR OUTER MAST) -----	99
6101-41	ROLLER, LIFT (FOR INNER MAST) -----	2
6101-41A	SHIM, LIFT ROLLER (FOR INNER MAST) -----	99
6101-53	CUSHION, MAST (FOR INNER MAST) -----	1
6101-AC	STOPPER, INNER MAST -----	1
6101-AD	FITTING, GREASE -----	2

(SV) ( 1 )

G208

FIG. 6301 LIFT BRACKET & FORK

# 6301

SV

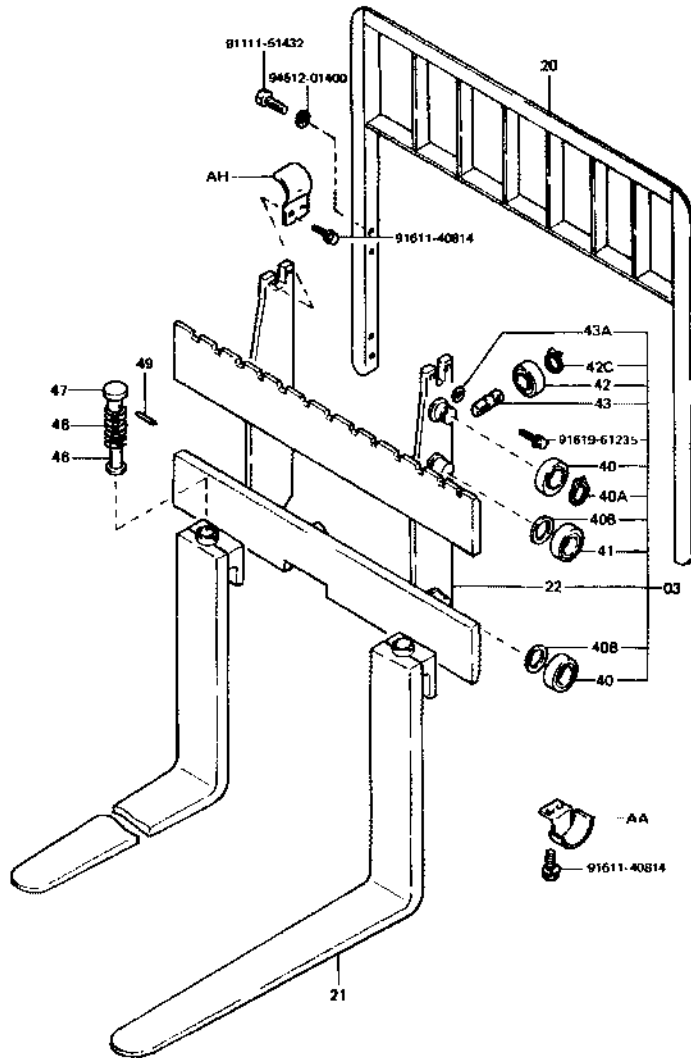

PART NAME CODE	PART NAME	QTY
6301-03	BRACKET ASSY, LIFT -----	1
6301-20	BACKREST SUB-ASSY -----	1
6301-21	FORK SUB-ASSY -----	2
6301-22	BRACKET SUB-ASSY, LIFT -----	1
6301-40	ROLLER, LIFT (UPPER, LOWER) -----	4
6301-40A	RING, SHAFT SNAP (UPPER, LOWER) -----	2
6301-40B	SHIM, LIFT ROLLER -----	99
6301-41	ROLLER, LIFT (CENTER) -----	2
6301-42	ROLLER, SIDE -----	2
6301-42C	RING, SHAFT SNAP (FOR SIDE ROLLER) -----	4
6301-43	SHAFT, SIDE ROLLER -----	2
6301-43A	SHIM (FOR SIDE ROLLER SHAFT) -----	99
6301-46	PIN, FORK STOPPER -----	2
6301-47	KNOB, FORK STOPPER PIN -----	2
6301-48	SPRING, FORK STOPPER PIN -----	2
6301-49	PIN, SPRING (FOR FORK STOPPER PIN) -----	2

(SV ) ( 2 )

G208

FIG. 6302 CHAIN & CHAIN WHEEL

**6302**

SV

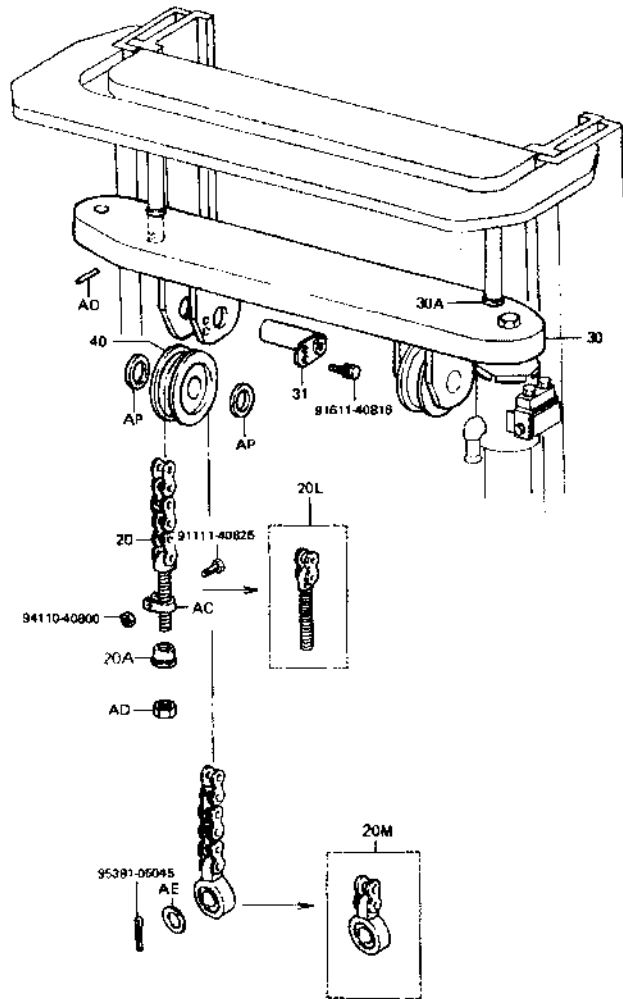

6302-018A

PART NAME CODE	PART NAME	QTY
6302-20	CHAIN SUB-ASSY -----	2
6302-20A	NUT, CHAIN ADJUST -----	2
6302-20L	BOLT KIT, CHAIN ANCHOR, NO.2 -----	2
6302-20M	BOLT KIT, CHAIN EYE -----	2
6302-30	BEAM SUB-ASSY, CHAIN -----	1
6302-30A	BUSHING -----	2
6302-31	PIN SUB-ASSY, CHAIN WHEEL -----	2
6302-40	WHEEL, CHAIN -----	2
6302-AC	CLAMP, CHAIN ANCHOR BOLT -----	2
6302-AD	NUT, HEXAGON -----	2
6302-AE	WASHER, CHAIN SPECIAL -----	2
6302-AD	PIN, SPRING -----	2
6302-AP	COLLAR, CHAIN WHEEL -----	4

(SV) ( 3 )

G208



FIG. 6501 LIFT CYLINDER

**6501**

SV

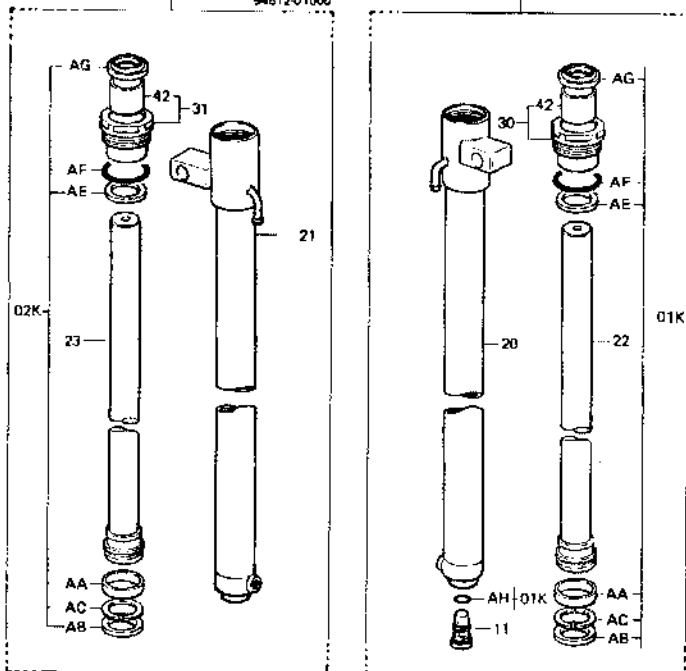
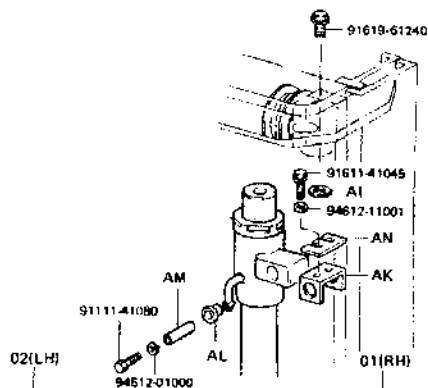

6501-011

PART NAME CODE	PART NAME	QTY
6501-01	CYLINDER ASSY, LIFT, RH	1
6501-01K	CYLINDER O/H KIT, LIFT, RH	1
6501-02	CYLINDER ASSY, LIFT, LH	1
6501-02K	CYLINDER O/H KIT, LIFT, LH	1
6501-11	VALVE ASSY, SAFETY DOWN	1
6501-20	CYLINDER SUB-ASSY, LIFT, RH	1
6501-21	CYLINDER SUB-ASSY, LIFT, LH	1
6501-22	ROD SUB-ASSY, LIFT CYLINDER, RH	1
6501-23	ROD SUB-ASSY, LIFT CYLINDER, LH	1
6501-30	GUIDE SUB-ASSY, LIFT CYLINDER ROD, RH	1
6501-31	GUIDE SUB-ASSY, LIFT CYLINDER ROD, LH	1
6501-42	SLEEVE, LIFT CYLINDER ROD GUIDE	2
6501-AA	RING, WEAR	2
6501-AB	PACKING, U	2
6501-AC	RING, BACK UP	2
6501-AE	PACKING, U	2
6501-AF	RING, O	2
6501-AG	SEAL, DUST	2
6501-AH	RING, U	1
6501-AI	SHIM	99
6501-AK	BRACKET SUB-ASSY, LIFT CYLINDER	2
6501-AL	BUSHING	4
6501-AM	SPACER	2
6501-AN	SHIM	99

(SV) (4)

G208

FIG. 6511 TILT CYLINDER

6511

SV

SV

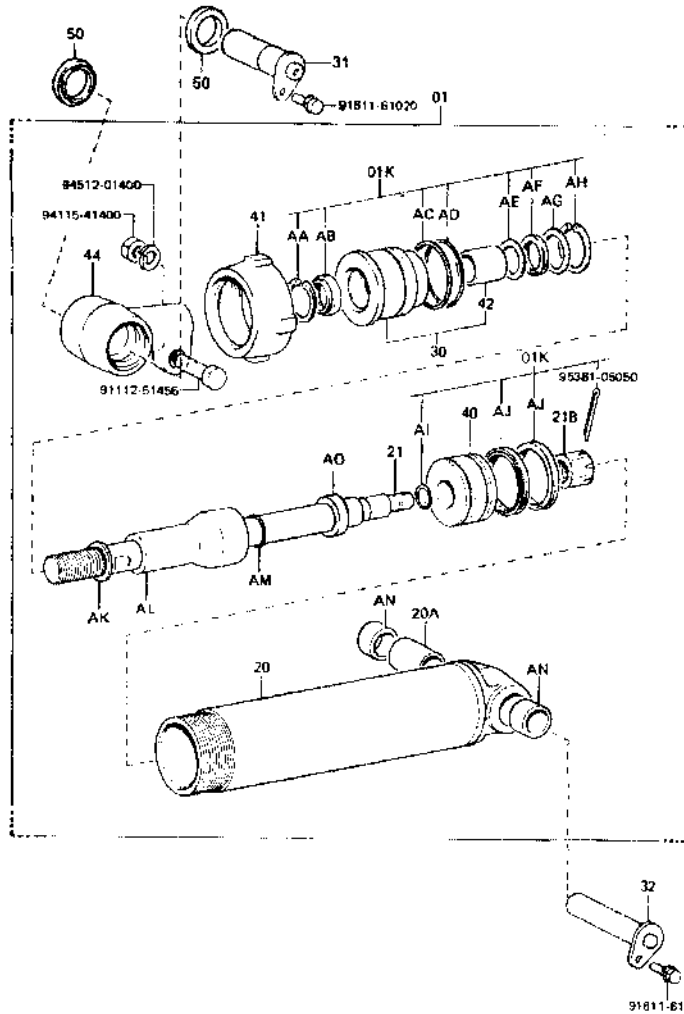

91811-61020

6511 010

テイルト角度表  
TABLE OF TILT RANGE

生産期間 PROD DATE	型式 MODELS	タイヤ TIRE	揚 高 LIFTING HEIGHT	備 考 DESCRIPTION	テイルト角 TILT RANGE
8003-	F, FV, M, SV, V	SINGLE	H2000-H4000		6D - 12D
8003-	F, FV, M, SV, V	DOUBLE	H2000-H4500		6D - 12D
8003-	F, FV, M, SV, V	SINGLE	H4500-H5000		6D - 6D
8003-	F, FV, M, SV, V	DOUBLE	H5000		6D - 6D
8003-	F, FV, M, SV, V		H2000	FRONT GLASS	6D - 10D
8003-	FSV, FS		H3700-H4700	DOMESTIC	6D - 6D
8003-	FSV, FS		H5000-H8500	DOMESTIC	3D - 6D
8003-	FSV, FS		H3700-H8500	EXPORT	6D - 6D
8003-	F, FV, M, SV, V	SINGLE	H2000-H4000	AUSTRALIA	3D - 12D
8003-	F, FV, M, SV, V	DOUBLE	H2000-H4500	AUSTRALIA	3D - 12D
8003-	F, FV, M, SV, V	SINGLE	H4500-H5000	AUSTRALIA	3D - 6D
8003-	F, FV, M, SV, V	DOUBLE	H5000	AUSTRALIA	3D - 6D
8003-	F, FV, M, SV, V		H2000	FRONT GLASS AUSTRALIA	3D - 6D
8003-	FV, M, SV, V		H3700-H8500	AUSTRALIA	3D - 6D

FIG. 6511 TILT CYLINDER

# 6511

SV

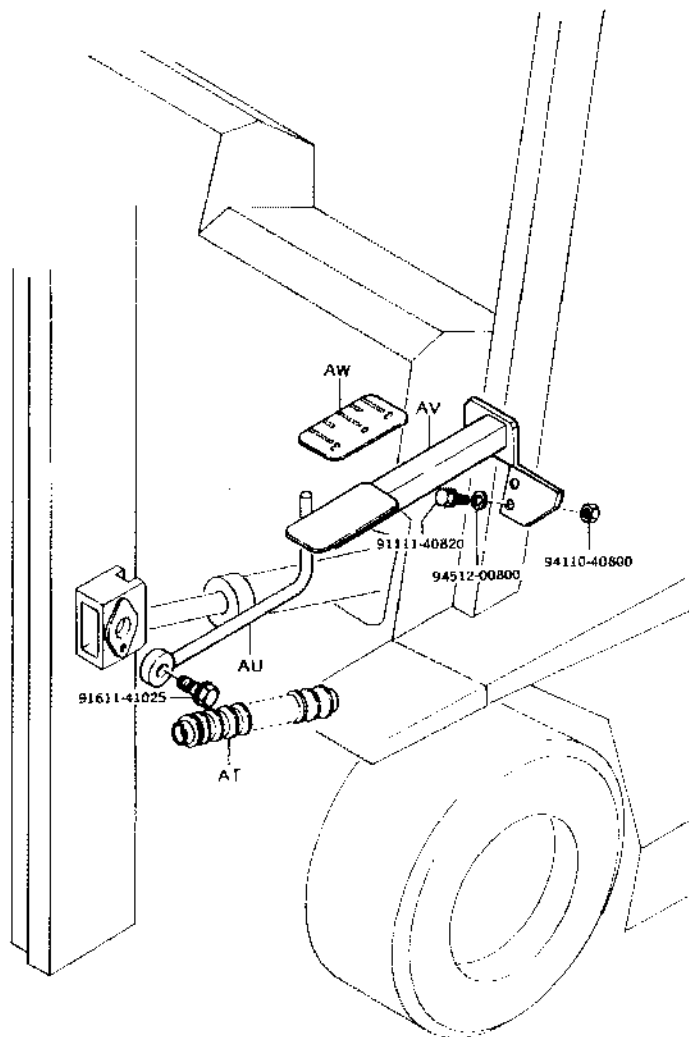

6511 013

PART NAME CODE	PART NAME	QTY
6511-01	CYLINDER ASSY, TILT -----	2
6511-01K	CYLINDER O/H KIT, TILT -----	2
6511-20	CYLINDER SUB-ASSY, TILT -----	2
6511-20A	BUSH, PIN (FOR CYLINDER) -----	2
6511-21	ROD SUB-ASSY, TILT CYLINDER PISTON -----	2
6511-21B	NUT, CASTLE -----	2
6511-30	GUIDE SUB-ASSY, TILT CYLINDER ROD -----	2
6511-31	PIN SUB-ASSY, TILT CYLINDER, FR -----	2
6511-32	PIN SUB-ASSY, TILT CYLINDER, RR -----	2
6511-40	PISTON, TILT CYLINDER -----	2
6511-41	COVER, TILT CYLINDER -----	2
6511-42	SLEEVE, TILT CYLINDER ROD GUIDE -----	2
6511-44	JOINT, PISTON ROD -----	2
6511-50	SEAL, GREASE -----	4
6511-AA	RING, HDLE SNAP -----	2
6511-AB	SEAL, DUST -----	2
6511-AC	RING, BACK UP -----	2
6511-AD	RING, O -----	2
6511-AE	RING, BACK UP -----	2
6511-AF	PACKING, U -----	2
6511-AG	PLATE, STOPPER -----	2
6511-AH	RING, HOLE SNAP -----	2
6511-AI	RING, O -----	2
6511-AJ	PACKING, U -----	4
6511-AK	SHIM, TILT CONTROL -----	99
6511-AL	SPACER, TILT CONTROL -----	2
6511-AM	RING, O -----	4
6511-AN	COLLAR -----	4
6511-AD	SPACER, TILT CONTROL -----	2
6511-AT	BOOT SUB-ASSY -----	2
6511-AU	BAR SUB-ASSY, TILT GAUGE -----	1
6511-AV	BRACKET SUB-ASSY, TILT GAUGE -----	1
6511-AW	PLATE, TILT CYLINDER INDICATOR -----	1

(SV) (5)

G208

FIG. 6701 OIL PUMP

**6701**

SV

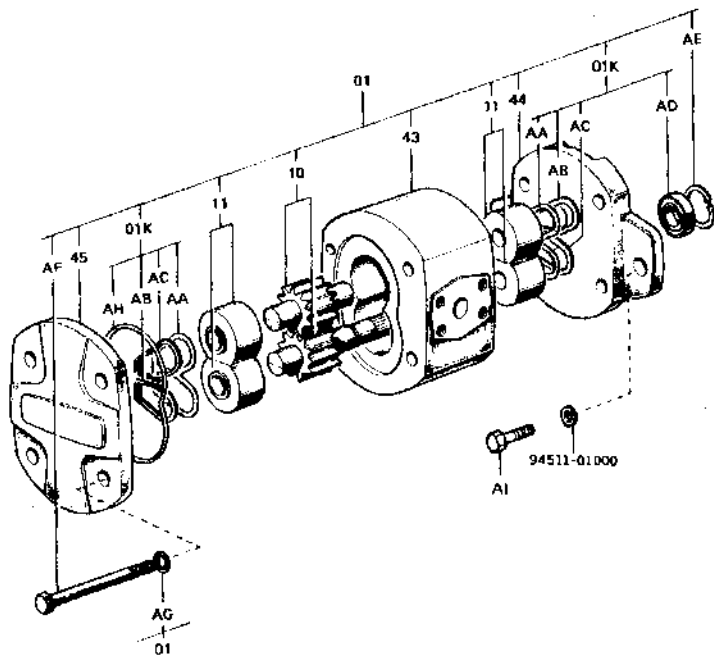

PART NAME CODE	PART NAME	QTY
6701-01	PUMP ASSY, OIL -----	1
6701-01K	PUMP O/H KIT, OIL -----	1
6701-10	GEAR SET -----	1
6701-11	BUSH SET, NO.1 -----	2
6701-43	BODY -----	1
6701-44	FLANGE, MOUNTING -----	1
6701-45	COVER -----	1
6701-AA	SEAL, BUSHING -----	2
6701-AB	RING, BACKING, RH -----	2
6701-AC	RING, BACKING, LH -----	2
6701-AD	SEAL, OIL -----	1
6701-AE	RING, SNAP -----	1
6701-AF	BOLT -----	4
6701-AG	WASHER, SPRING -----	4
6701-AH	SEAL, BODY -----	2
6701-AI	BOLT -----	2

6701-019

FIG. 6705 OIL CONTROL VALVE

6705

SV (UL)

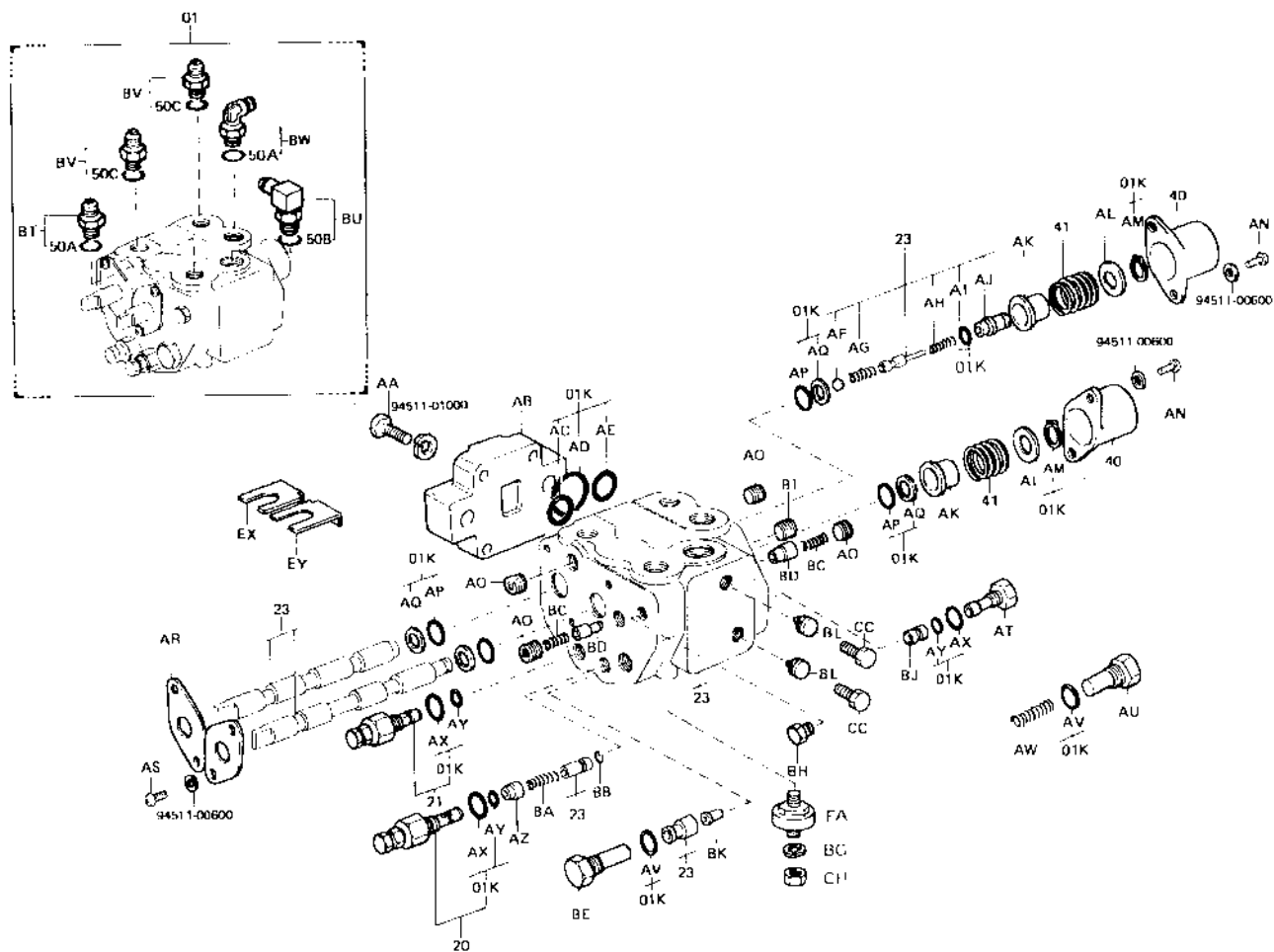

FIG. 6705 OIL CONTROL VALVE

6705

SV

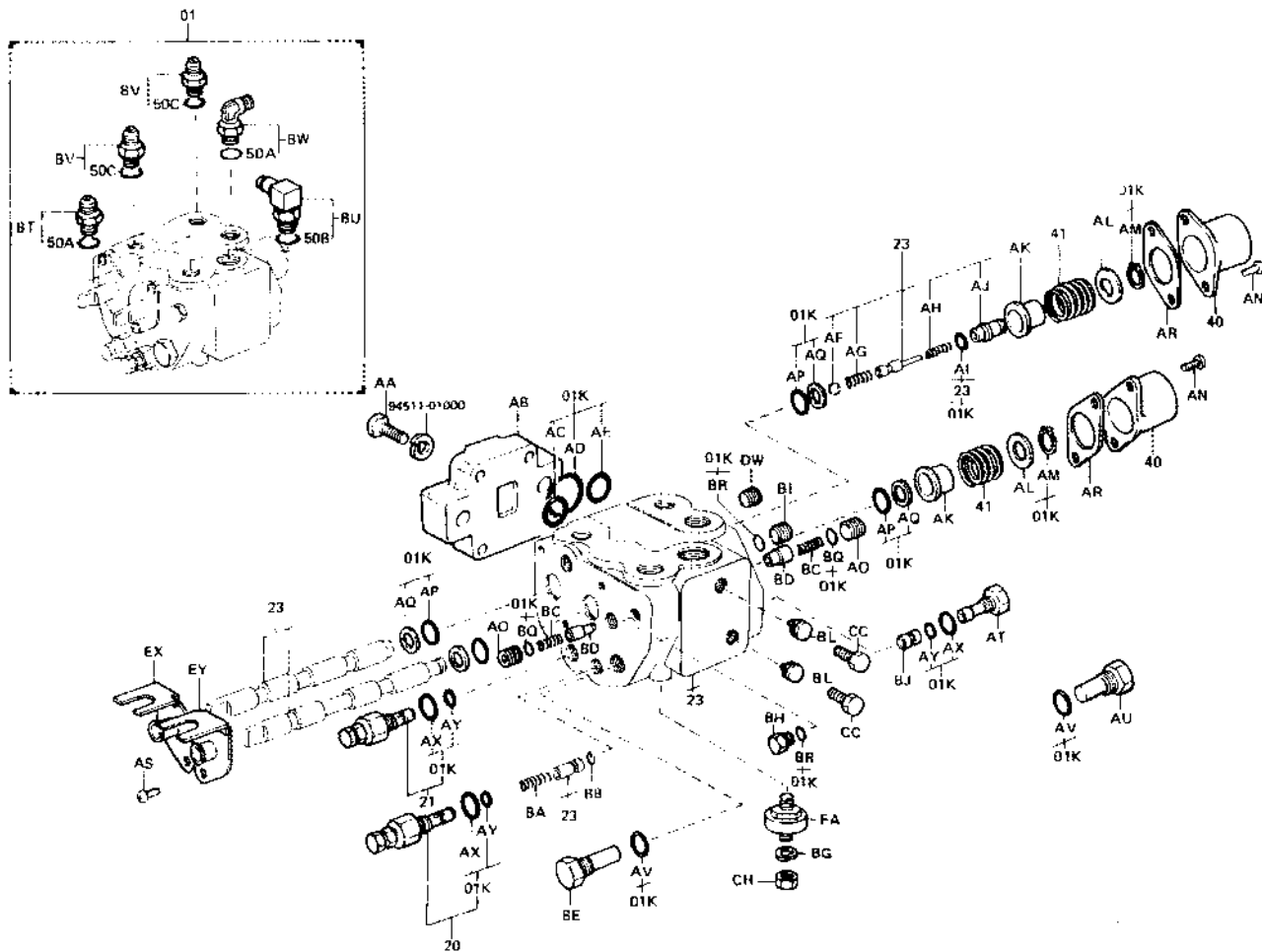

FIG. 6705 OIL CONTROL VALVE

6705

SV (3-WAY..UL)

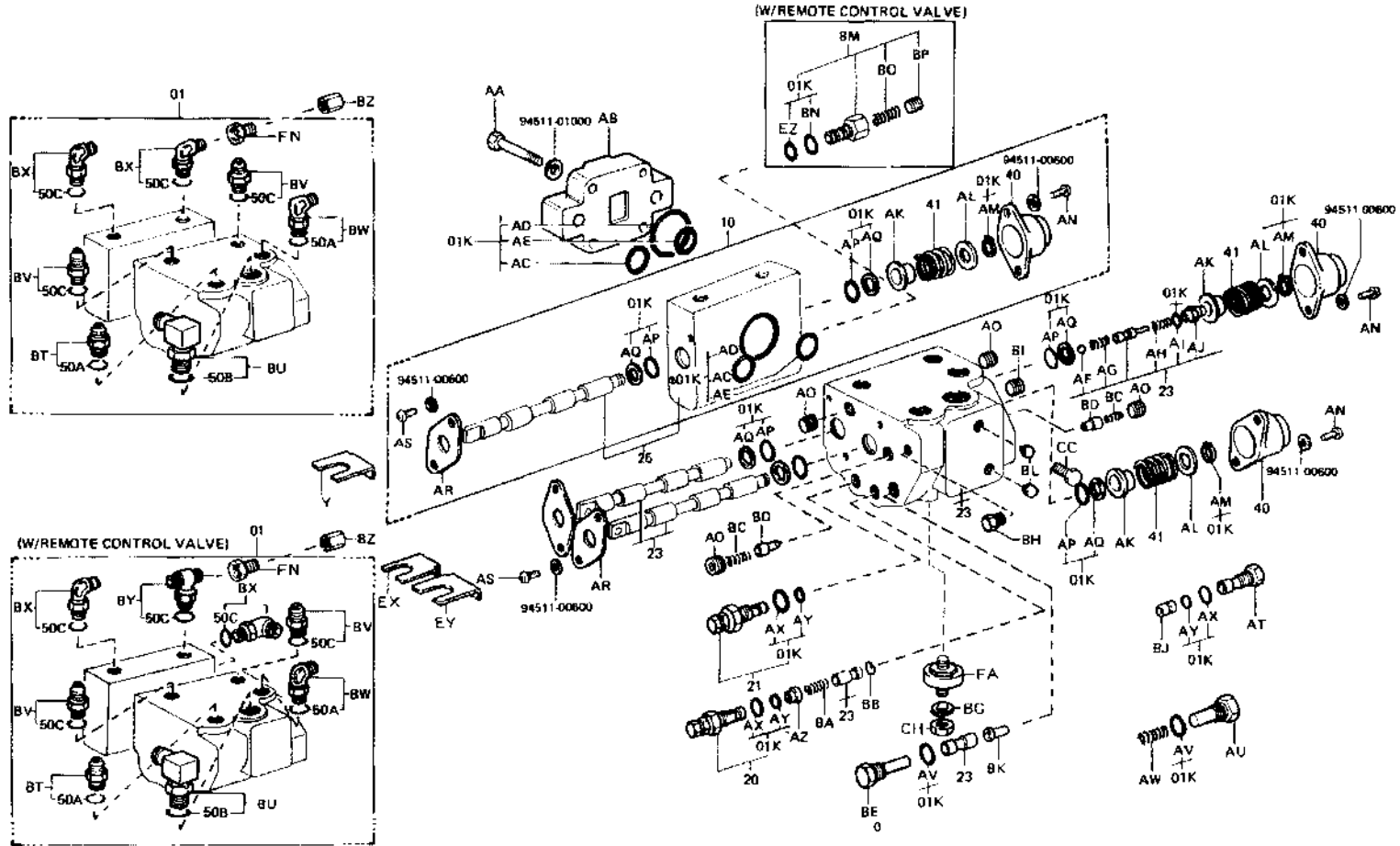

FIG. 6705 OIL CONTROL VALVE

6705

SV (3-WAY)

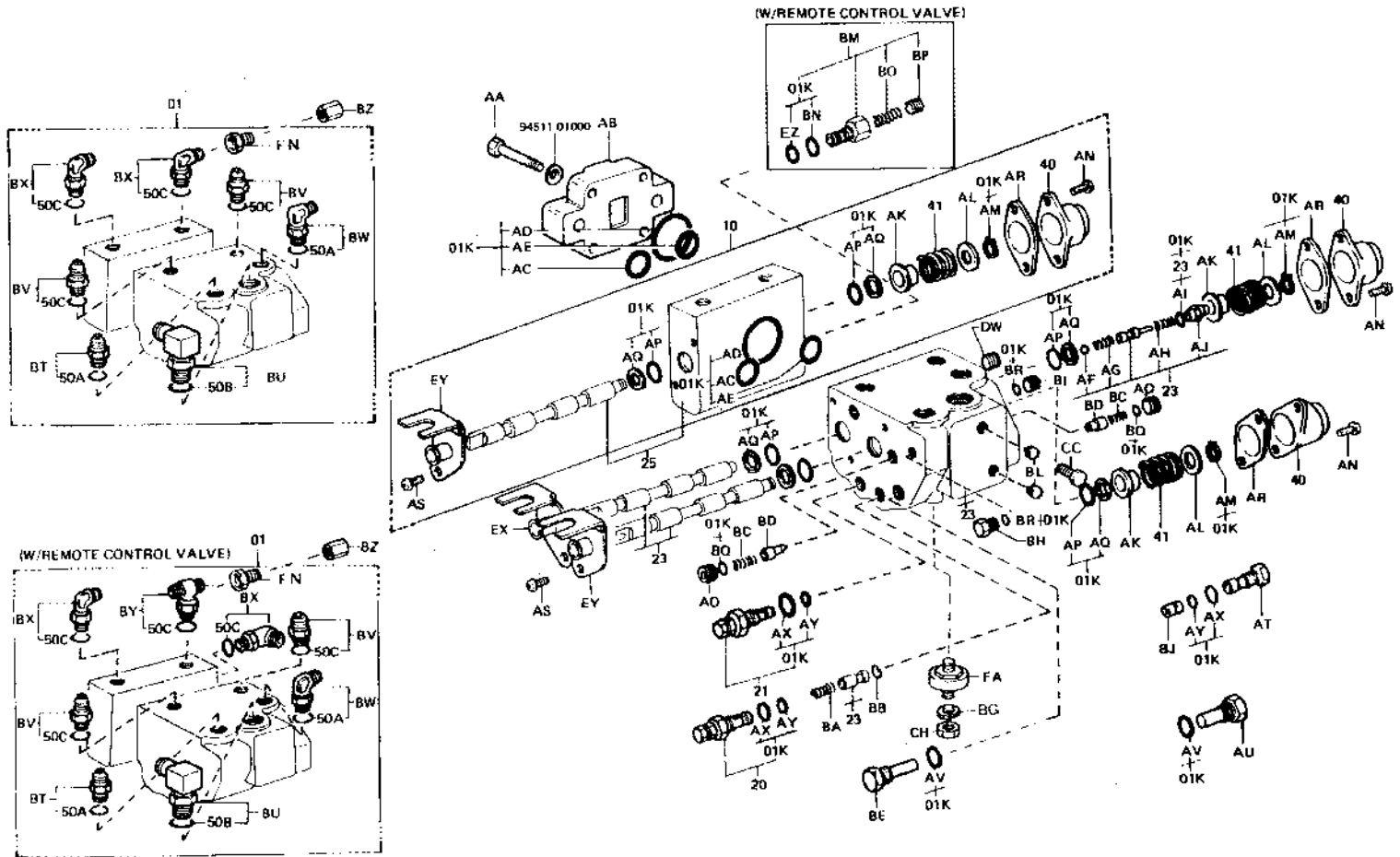
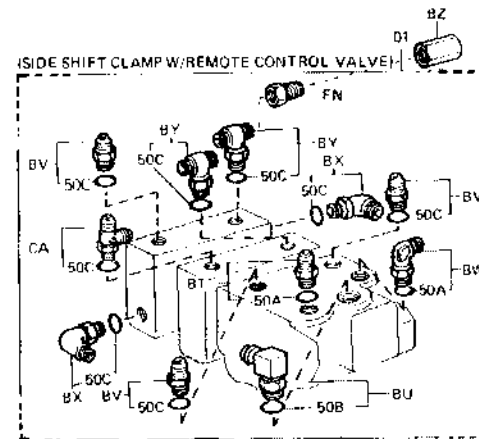
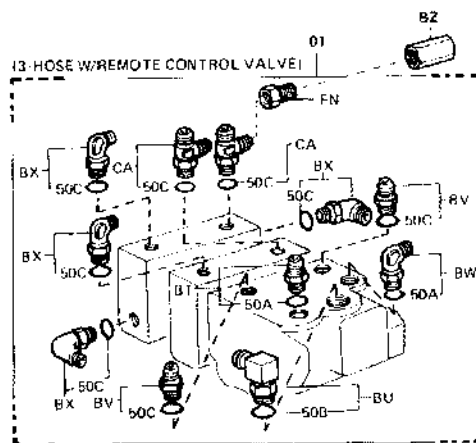
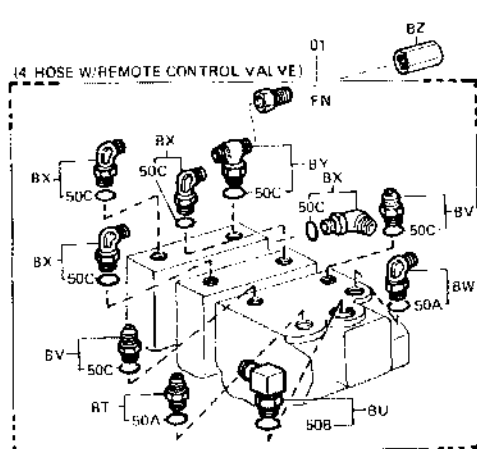
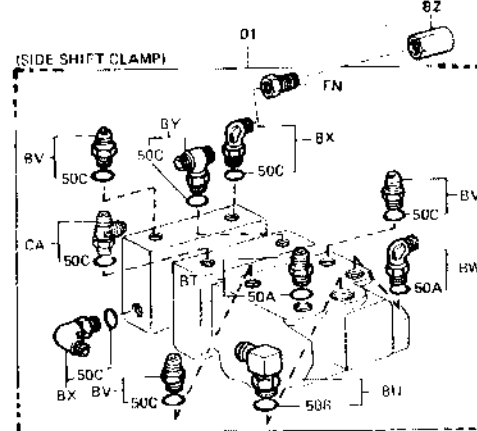
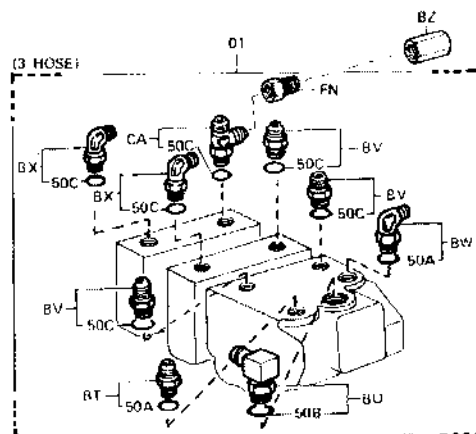
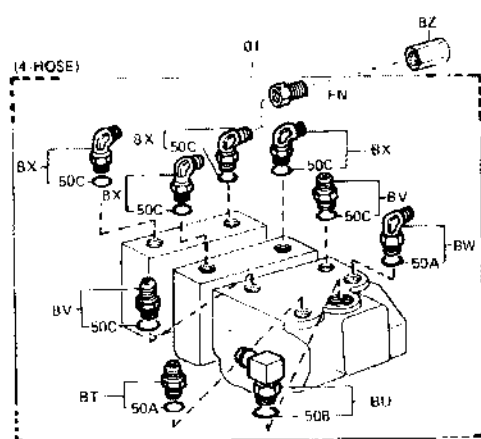



FIG. 6705 OIL CONTROL VALVE

6705

SV (4-WAY)



6705-05A



FIG. 6705 OIL CONTROL VALVE

6705

SV (4-WAY..UL)

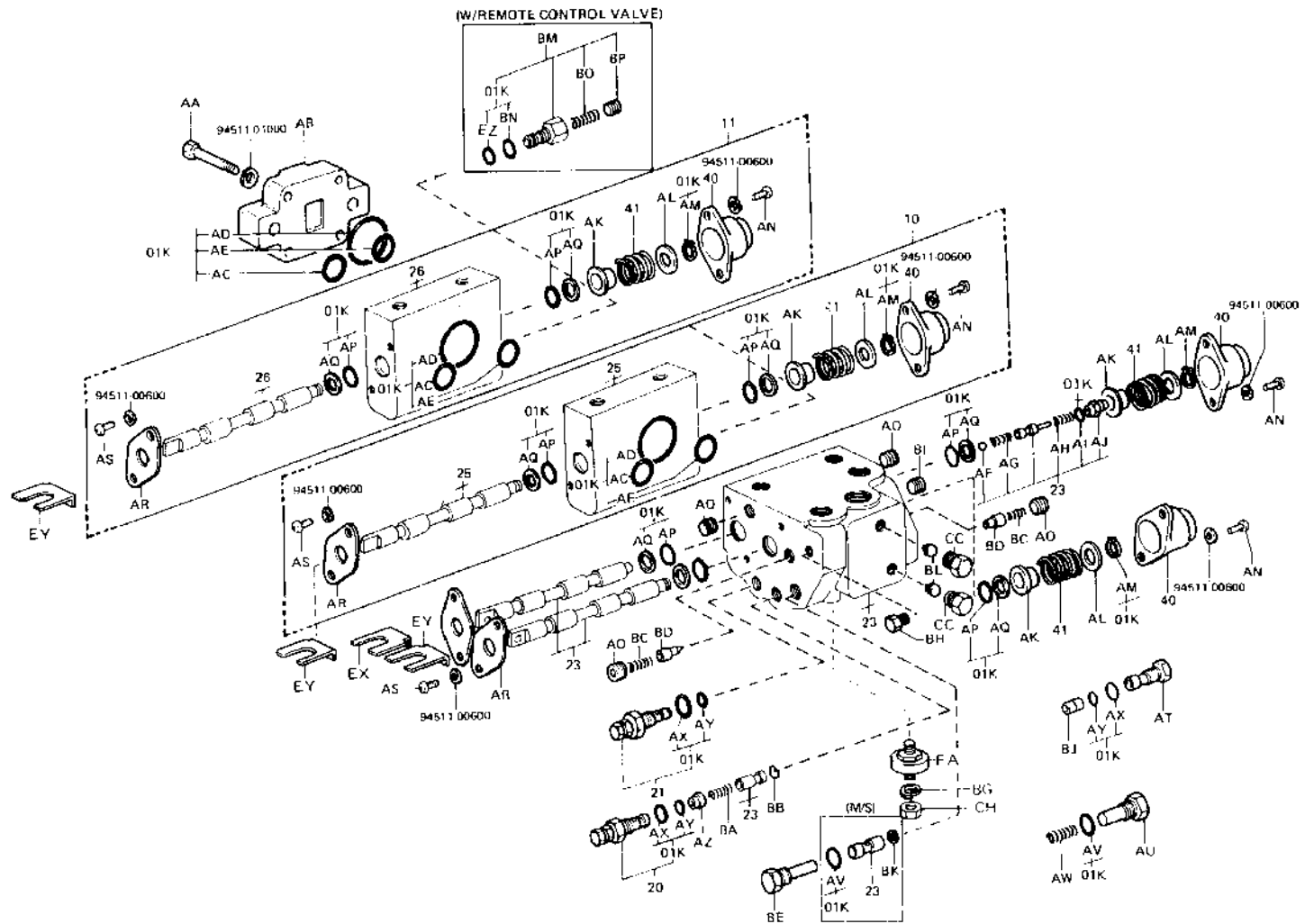



# 6705

PART NAME CODE	PART NAME	QTY
6705-01	VALVE ASSY, OIL CONTROL -----	1
6705-01K	VALVE O/H KIT, OIL CONTROL -----	1
6705-10	VALVE ASSY, PLUNGER SECTION, NO.1 -----	1
6705-11	VALVE ASSY, PLUNGER SECTION, NO.2 -----	1
6705-20	VALVE SET, PILOT RELIEF, NO.1 -----	1
6705-21	VALVE SET, PILOT RELIEF, NO.2 -----	1
6705-23	HOUSING & SPOOL SET, NO.1 -----	1
6705-25	HOUSING & SPOOL SET, ATTACHMENT, NO.1 -----	1
6705-26	HOUSING & SPOOL SET, ATTACHMENT, NO.2 -----	1
6705-40	COVER, SPRING -----	2
6705-41	SPRING, COMPRESSION (FOR SPOOL RETURN) -----	2
6705-50A	RING, O, NO.1 (FOR VALVE FITTING) -----	2
6705-50B	RING, O, NO.2 (FOR VALVE FITTING) -----	1
6705-50C	RING, O, NO.3 (FOR VALVE FITTING) -----	2
6705-AA	BOLT -----	4
6705-AB	HOUSING, OUTLET -----	1
6705-AC	RING, O -----	1
6705-AD	RING, O -----	1
6705-AE	RING, O -----	1
6705-AF	BALL, STEEL -----	1
6705-AG	SPRING -----	1
6705-AH	SPRING, COMPRESSION -----	1
6705-AI	RING, O -----	1
6705-AJ	STOPPER -----	1
6705-AK	HOLDER, SPRING -----	2
6705-AL	WASHER, PLATE -----	2
6705-AM	RING, SHAFT SNAP -----	2
6705-AN	SCREW -----	4
6705-AD	PLUG -----	2
6705-AP	RING, O -----	4
6705-AQ	RING, BACK UP -----	4
6705-AR	HOLDER, SEAL -----	2
6705-AS	SCREW -----	4
6705-AT	STOPPER -----	1
6705-AU	STOPPER -----	1
6705-AV	RING, O -----	2
6705-AW	SPRING, COMPRESSION -----	1
6705-AX	RING, O -----	3
6705-AY	RING, O -----	3
6705-AZ	COLLAR -----	1
6705-BA	SPRING, COMPRESSION -----	1
6705-BB	WIRE, ORIFICE TURNING -----	1
6705-BC	SPRING, COMPRESSION -----	2
6705-BD	PLUNGER, CHECK -----	2
6705-BE	STOPPER -----	1
6705-BG	WASHER -----	4
6705-BH	PLUG -----	1
6705-BI	PLUG -----	1
6705-BJ	SEAT, VALVE -----	1
6705-BK	VALVE, CHECK -----	1
6705-BL	SEAT, INSERT -----	2
6705-BM	VALVE SUB-ASSY, RELIEF -----	1
6705-BN	RING, O -----	1

(SV ) ( 7 ) G208

PART NAME CODE	PART NAME	QTY
6705-BD	SPRING -----	1
6705-BP	STOPPER -----	1
6705-BQ	RING, O -----	2
6705-BR	RING, O -----	2
6705-BT	FITTING -----	1
6705-BU	FITTING -----	1
6705-BV	FITTING -----	2
6705-BW	FITTING -----	1
6705-BX	FITTING -----	2
6705-BY	FITTING -----	1
6705-BZ	PLUG -----	2
6705-CA	FITTING -----	1
6705-CC	PLUG -----	2
6705-CH	NUT -----	4
6705-DW	PLUG -----	1
6705-EX	BRACKET SUB-ASSY, TILT -----	1
6705-EY	BRACKET SUB-ASSY, LIFT -----	1
6705-EZ	RING, O -----	1
6705-FA	INSULATOR -----	4
6705-FN	FITTING -----	2

(SV ) ( 8 ) G208

FIG. 6709 OIL CONTROL VALVE LINK

6709

SV

SV (3-WAY)

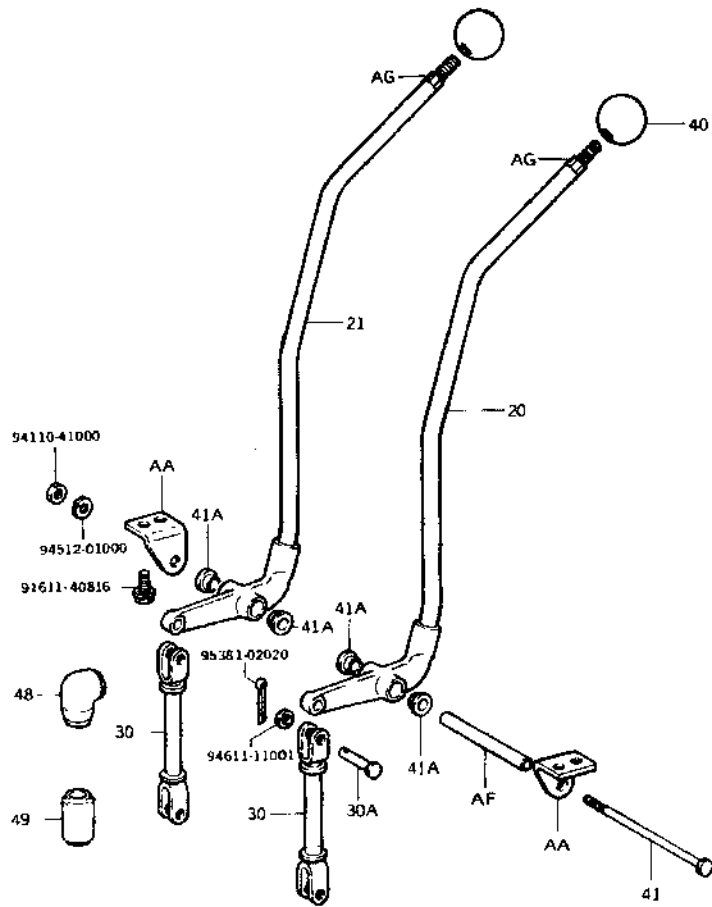

6709-016

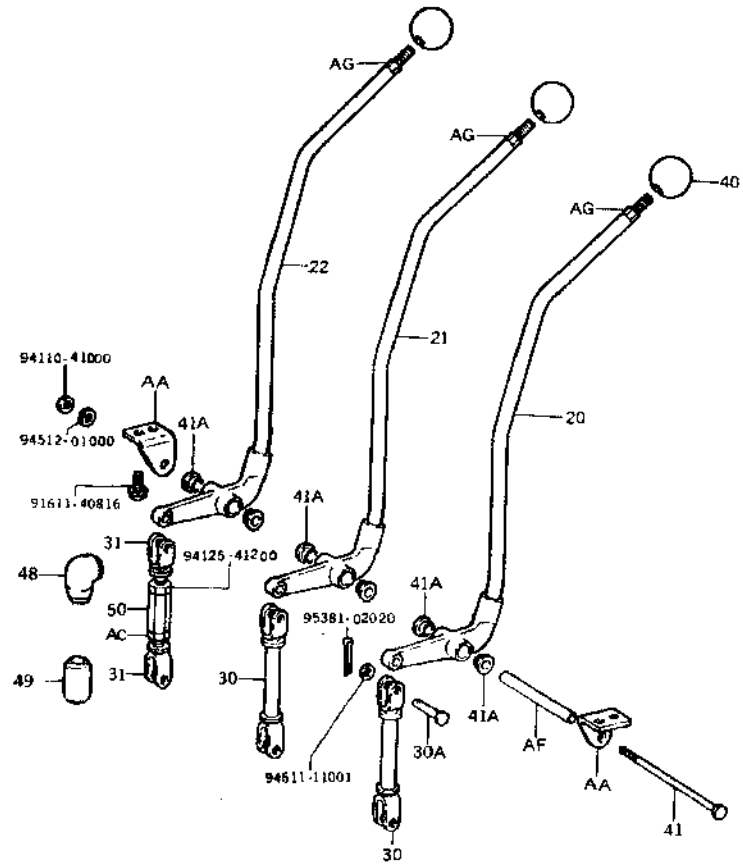

6709-017

FIG. 6709 OIL CONTROL VALVE LINK

**6709**

SV (4-WAY)

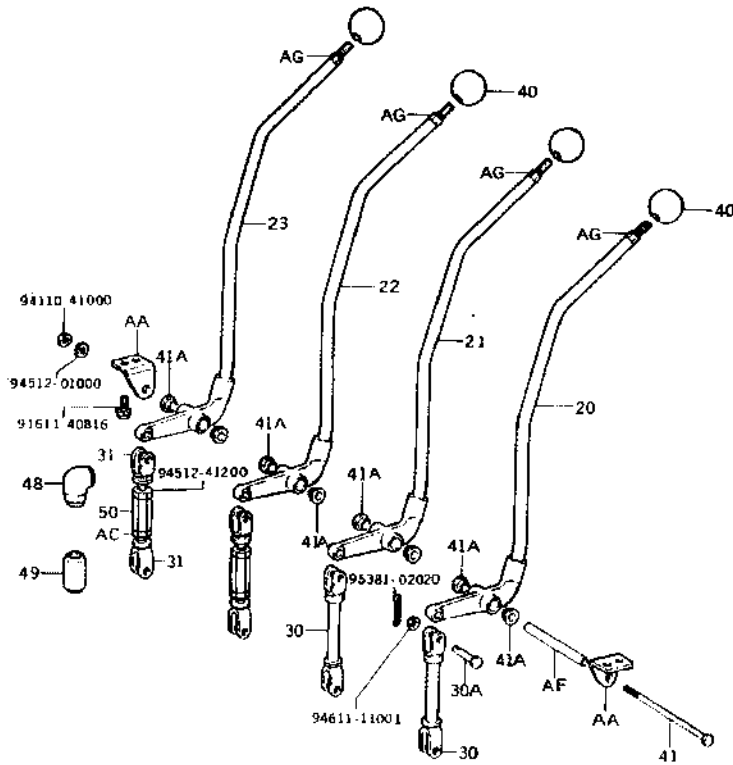

6709 018

PART NAME CODE	PART NAME	QTY
6709-20	LEVER SUB-ASSY, CONTROL VALVE, NO.1	1
6709-21	LEVER SUB-ASSY, CONTROL VALVE, NO.2	1
6709-22	LEVER SUB-ASSY, CONTROL VALVE, NO.3	1
6709-23	LEVER SUB-ASSY, CONTROL VALVE, NO.4	1
6709-30	ROD SUB-ASSY, CONTROL VALVE LEVER, NO.1	1
6709-30A	PIN (FOR CONTROL VALVE LEVER ROD)	4
6709-31	ROD SUB-ASSY, CONTROL VALVE LEVER, NO.2	1
6709-40	KNOB, OIL CONTROL VALVE LEVER	2
6709-41	PIN, OIL CONTROL VALVE LEVER	1
6709-41A	BUSH (FOR LEVER PIN)	4
6709-48	BOOT, CONTROL VALVE LINK, NO.1	2
6709-49	BOOT, CONTROL VALVE LINK, NO.2	2
6709-50	TURNBUCKLE	1
6709-AA	BRACKET SUB-ASSY	1
6709-AC	NUT	1
6709-AF	SPACER	1
6709-AG	BOLT, STUD	2

(SV ) ( 9 )

G208

FIG. 8801 BODY PIPING

6801

SV

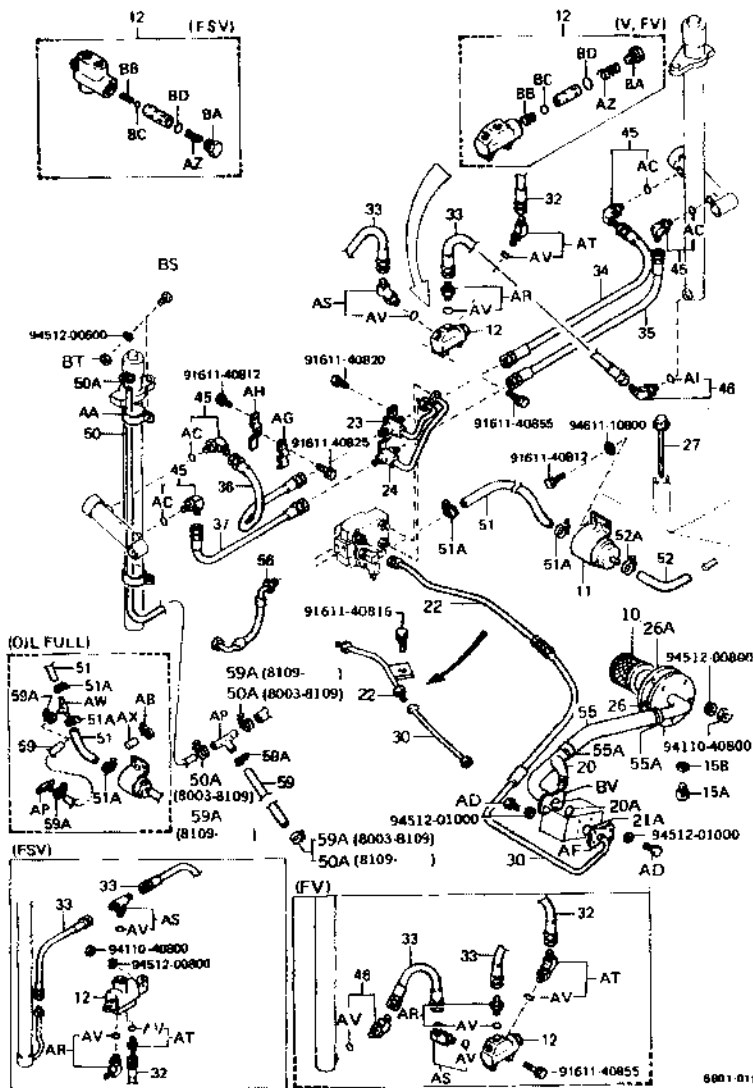

PART NAME CODE	PART NAME	QTY
6801-10	FILTER ASSY, SUCTION	1
6801-11	FILTER ASSY, RETURN	1
6801-12	VALVE ASSY, FLOW REGULATOR	1
6801-15A	PLUG (FOR OIL TANK DRAIN)	1
6801-15B	GASKET (FOR OIL TANK DRAIN PLUG)	1
6801-20	PIPE SUB-ASSY (PUMP INLET)	1
6801-20A	RING, O (FOR OIL PUMP INLET)	1
6801-21A	RING, O (FOR OIL PUMP OUTLET)	1
6801-22	PIPE SUB-ASSY (PUMP TO VALVE)	1
6801-23	PIPE SUB-ASSY (TILT CYLINDER FRONT)	1
6801-24	PIPE SUB-ASSY (TILT CYLINDER REAR)	1
6801-26	OUTLET SUB-ASSY, OIL TANK	1
6801-26A	PACKING, OIL TANK COVER	1
6801-27	CAP SUB-ASSY, OIL TANK	1
6801-30	HOSE, HIGH PRESSURE, NO.1 (PUMP TO VALVE)	1
6801-32	HOSE, HIGH PRESSURE, NO.1 (VALVE TO LIFT)	1
6801-33	HOSE, HIGH PRESSURE, NO.2 (VALVE TO LIFT)	2
6801-34	HOSE, HIGH PRESSURE, NO.1 (TILT FRONT)	1
6801-35	HOSE, HIGH PRESSURE, NO.1 (TILT REAR)	1
6801-36	HOSE, HIGH PRESSURE, NO.2 (TILT FRONT)	1
6801-37	HOSE, HIGH PRESSURE, NO.2 (TILT REAR)	1
6801-45	FITTING (FOR TILT CYLINDER)	2
6801-46	FITTING (FOR LIFT CYLINDER)	2
6801-50	HOSE, LOW PRESSURE, NO.1 (LIFT TO TANK)	2
6801-50A	CLAMP (FOR LIFT TO TANK NO.1 HOSE)	3- 4
6801-51	HOSE, LOW PRESSURE, NO.1 (VALVE TO TANK)	1
6801-51A	CLAMP (FOR VALVE TO TANK NO.1 HOSE)	2
6801-52	HOSE, LOW PRESSURE, NO.2 (VALVE TO TANK)	1
6801-52A	CLAMP (FOR VALVE TO TANK NO.2 HOSE)	2
6801-55	HOSE, LOW PRESSURE (TANK TO PUMP)	1
6801-55A	CLAMP (FOR TANK TO PUMP HOSE)	2
6801-56	HOSE, LOW PRESSURE (STEERING TO VALVE)	1
6801-59	HOSE, LOW PRESSURE, NO.2 (LIFT TO TANK)	1
6801-59A	CLAMP (FOR LIFT TO TANK NO.2 HOSE)	2- 3
6801-AA	BAND, LIFT CYLINDER OVERFLOW HOSE	4
6801-AB	CLAMP	1
6801-AC	RING, O	4
6801-AD	BOLT	8
6801-AF	FLANGE, SPLIT	1
6801-AG	CLAMP	1
6801-AH	BRACKET SUB-ASSY, TILT HOSE	1
6801-AI	RING, O	2
6801-AP	PIPE	1
6801-AR	FITTING	1
6801-AS	FITTING	1
6801-AT	FITTING	1
6801-AV	RING, O	3
6801-AX	CAP, OIL TANK OVERFLOW PIPE	1
6801-AZ	SPRING, COMPRESSION	1
6801-BA	PLUG	1
6801-BB	SPRING, COMPRESSION	1
6801-BC	BALL, STEEL	1
6801-BD	RING, O	1

(SV ) ( 10 )

G208

**6801**

PART NAME CODE	PART NAME	QTY
6801-85	BOLT -----	5
6801-87	WASHER -----	5
6801-8V	FLANGE -----	2

(SV

) ( 11)

G208



FIG. 6101 MAST

**6101**

V

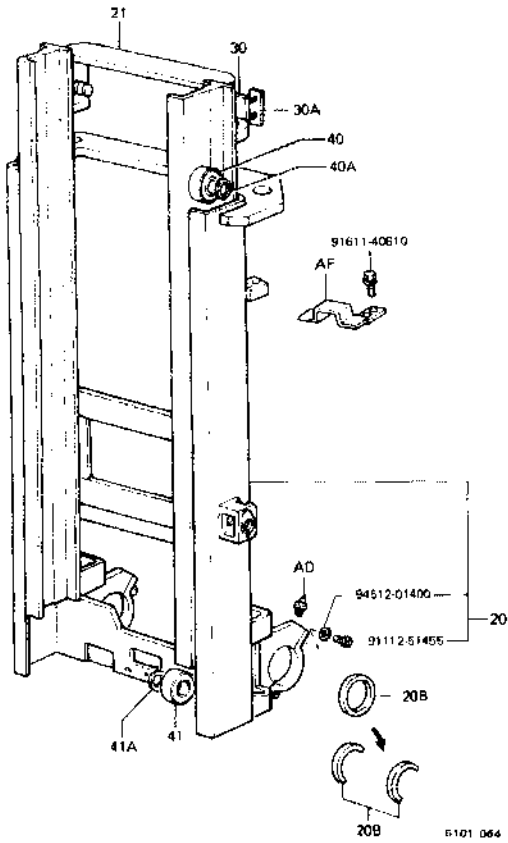

PART NAME CODE	PART NAME	QTY
6101-20	MAST SUB-ASSY, OUTER -----	1
6101-20B	BUSH, MAST SUPPORT -----	1
6101-21	MAST SUB-ASSY, INNER -----	1
6101-30	STRIP SUB-ASSY, OUTER MAST -----	2
6101-30A	SHIM, OUTER MAST STRIP -----	99
6101-40	ROLLER, LIFT (FOR OUTER MAST) -----	2
6101-40A	SHIM, LIFT ROLLER (FOR OUTER MAST) -----	99
6101-41	ROLLER, LIFT (FOR INNER MAST) -----	2
6101-41A	SHIM, LIFT ROLLER (FOR INNER MAST) -----	99
6101-AD	FITTING, GREASE -----	2
6101-AF	COVER, ROLLER -----	1

(V ) ( 1 )

G298

FIG. 6301 LIFT BRACKET & FORK

# 6301

V

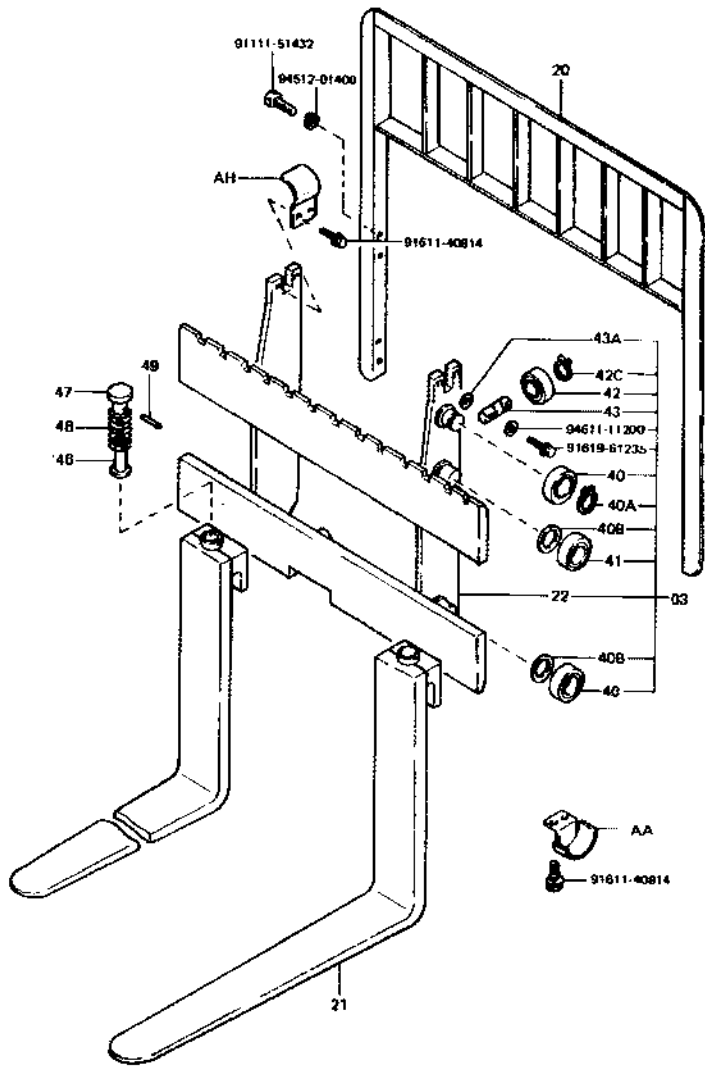

PART NAME CODE	PART NAME	QTY
6301-03	BRACKET ASSY, LIFT -----	1
6301-20	BACKREST SUB-ASSY -----	1
6301-21	FORK SUB-ASSY -----	2
6301-22	BRACKET SUB-ASSY, LIFT -----	1
6301-40	ROLLER, LIFT (UPPER, LOWER) -----	4
6301-40A	RING, SHAFT SNAP (UPPER, LOWER) -----	2
6301-40B	SHIM, LIFT ROLLER -----	99
6301-41	ROLLER, LIFT (CENTER) -----	2
6301-42	ROLLER, SIDE -----	2
6301-42C	RING, SHAFT SNAP (FOR SIDE ROLLER) -----	4
6301-43	SHAFT, SIDE ROLLER -----	2
6301-43A	SHIM (FOR SIDE ROLLER SHAFT) -----	99
6301-46	PIN, FORK STOPPER -----	2
6301-47	KNOB, FORK STOPPER PIN -----	2
6301-48	SPRING, FORK STOPPER PIN -----	2
6301-49	PIN, SPRING (FOR FORK STOPPER PIN) -----	2
6301-AA	COVER, LIFT BRACKET ROLLER -----	2
6301-AH	COVER, LIFT BRACKET ROLLER -----	2

(V ) ( 2 )

G208

FIG. 6302 CHAIN & CHAIN WHEEL

**6302**

V

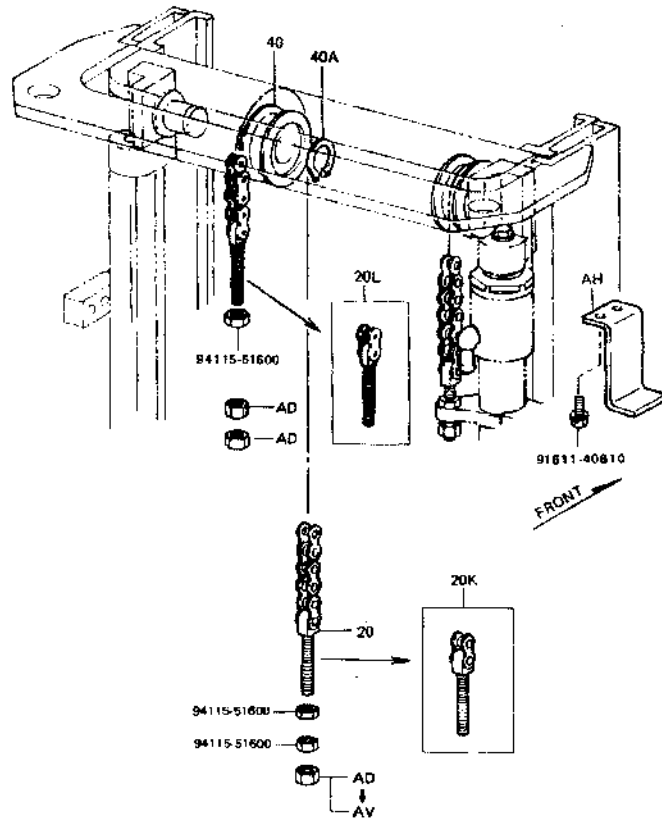

6302-0068

PART NAME CODE	PART NAME	QTY
6302-20	CHAIN SUB-ASSY -----	2
6302-20L	BOLT KIT, CHAIN ANCHOR, NO.2 -----	2
6302-21K	BOLT KIT, CHAIN ANCHOR, NO.1 (FRONT) -----	2
6302-40	WHEEL, CHAIN -----	2
6302-40A	RING, SHAFT SNAP (FOR CHAIN WHEEL) -----	2
6302-AD	NUT, HEXAGON -----	4
6302-AH	COVER, CHAIN WHEEL -----	2
6302-AV	NUT -----	2

FIG. 6501 LIFT CYLINDER

**6501**

V

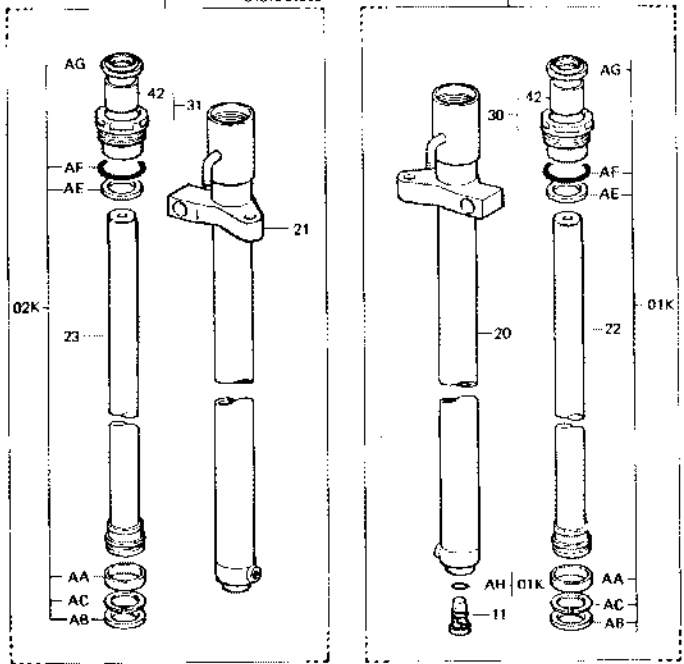
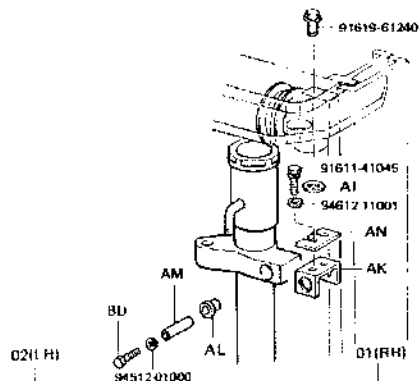

6501-003A

PART NAME CODE	PART NAME	QTY
6501-01	CYLINDER ASSY, LIFT, RH	1
6501-01K	CYLINDER O/H KIT, LIFT, RH	1
6501-02	CYLINDER ASSY, LIFT, LH	1
6501-02K	CYLINDER O/H KIT, LIFT, LH	1
6501-11	VALVE ASSY, SAFETY DOWN	1
6501-20	CYLINDER SUB-ASSY, LIFT, RH	1
6501-21	CYLINDER SUB-ASSY, LIFT, LH	1
6501-22	ROD SUB-ASSY, LIFT CYLINDER, RH	1
6501-23	ROD SUB-ASSY, LIFT CYLINDER, LH	1
6501-30	GUIDE SUB-ASSY, LIFT CYLINDER ROD, RH	1
6501-31	GUIDE SUB-ASSY, LIFT CYLINDER ROD, LH	1
6501-42	SLEEVE, LIFT CYLINDER ROD GUIDE	2
6501-AA	RING, WEAR	2
6501-AB	PACKING, U	2
6501-AC	RING, BACK UP	2
6501-AE	PACKING, U	2
6501-AF	RING, O	2
6501-AG	SEAL, DUST	2
6501-AH	RING, G	1
6501-AI	SHIM	99
6501-AK	BRACKET SUB-ASSY, LIFT CYLINDER	2
6501-AL	BUSHING	4
6501-AM	SPACER	2
6501-AN	SHIM	99
6501-BD	BOLT	2

FIG. 6511 TILT CYLINDER

6511

V

V

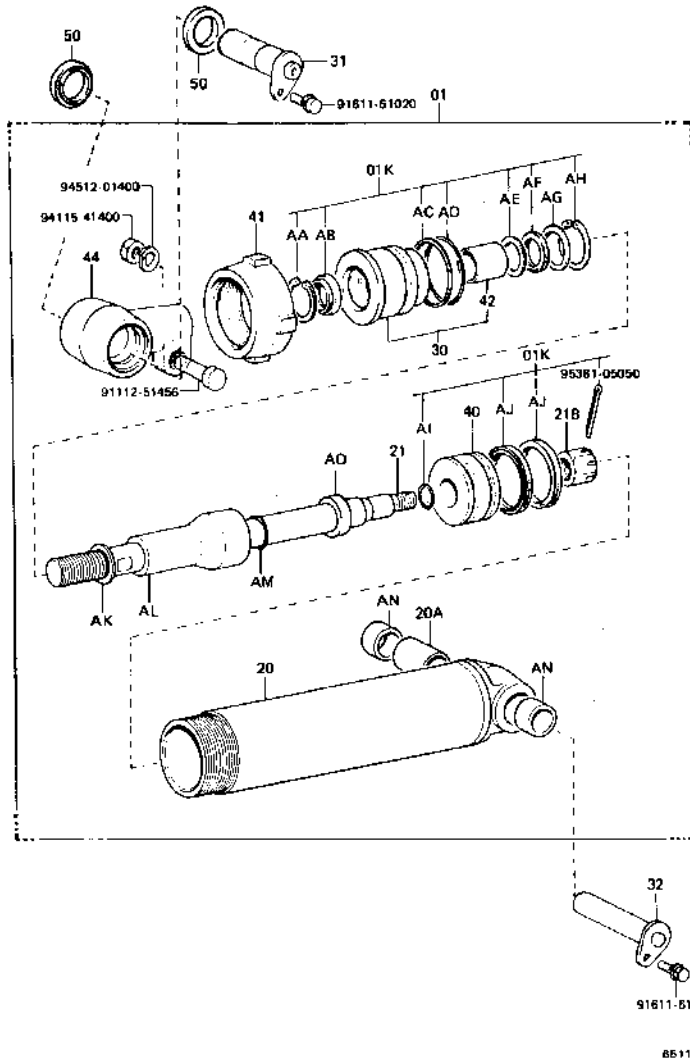

テイルト角度表  
TABLE OF TILT RANGE

生産期間 PROD DATE	型式 MODELS	タイヤ TIRE	繰 高 LIFTING HEIGHT	備 考 DESCRIPTION	テイルト角 TILT RANGE
8003-	F, FV, M, SV, V	SINGLE	H2000-H4000		6D - 12D
8003-	F, FV, M, SV, V	DOUBLE	H2000-H4500		6D - 12D
8003-	F, FV, M, SV, V	SINGLE	H4500-H5000		6D - 6D
8003-	F, FV, M, SV, V	DOUBLE	H5000		6D - 6D
8003-	F, FV, M, SV, V		H2000	FRONT GLASS	6D - 10D
8003-	FSV, FS		H3700-H4700	DOMESTIC	6D - 6D
8003-	FSV, FS		H5000-H6500	DOMESTIC	3D - 6D
8003-	FSV, FS		H3700-H6500	EXPORT	6D - 6D
8003-	F, FV, M, SV, V	SINGLE	H2000-H4000	AUSTRALIA	3D - 12D
8003-	F, FV, M, SV, V	DOUBLE	H2000-H4500	AUSTRALIA	3D - 12D
8003-	F, FV, M, SV, V	SINGLE	H4500-H5000	AUSTRALIA	3D - 6D
8003-	F, FV, M, SV, V	DOUBLE	H5000	AUSTRALIA	3D - 6D
8003-	F, FV, M, SV, V		H2000	FRONT GLASS AUSTRALIA	3D - 6D
8003-	FV, M, SV, V		H3700-H6500	AUSTRALIA	3D - 6D

FIG. 8511 TILT CYLINDER

6511

V

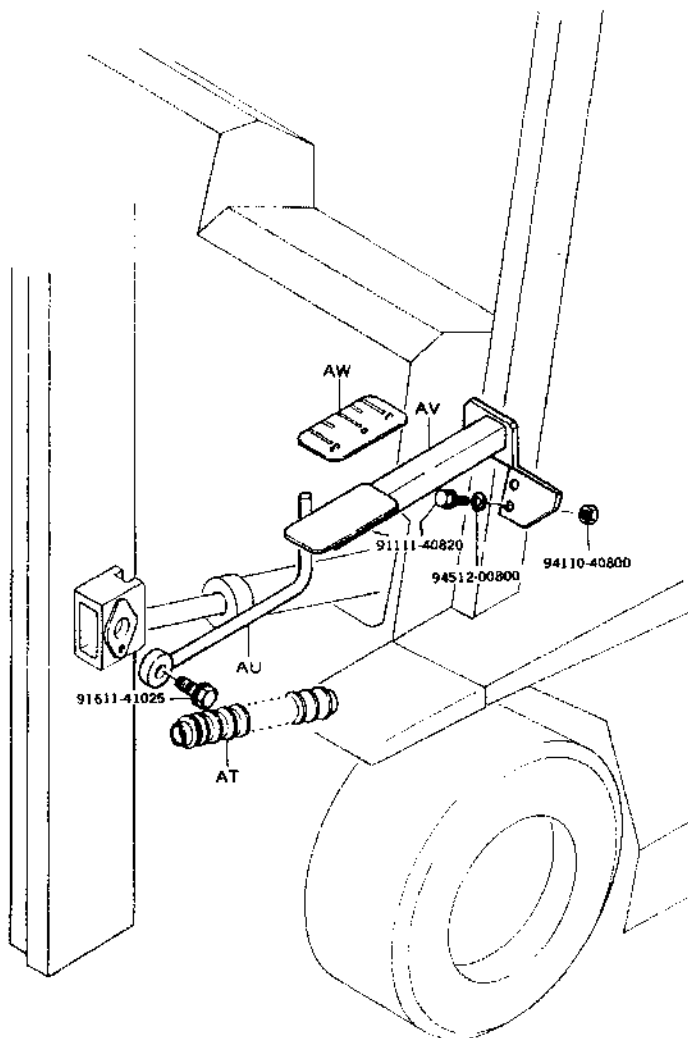

6511 013

PART NAME CODE	PART NAME	QTY
6511-01	CYLINDER ASSY, TILT -----	2
6511-01K	CYLINDER O/H KIT, TILT -----	2
6511-20	CYLINDER SUB-ASSY, TILT -----	2
6511-20A	BUSH, PIN (FOR CYLINDER) -----	2
6511-21	ROD SUB-ASSY, TILT CYLINDER PISTON -----	2
6511-21B	NUT, CASTLE -----	2
6511-30	GUIDE SUB-ASSY, TILT CYLINDER ROD -----	2
6511-31	PIN SUB-ASSY, TILT CYLINDER, FR -----	2
6511-32	PIN SUB-ASSY, TILT CYLINDER, RR -----	2
6511-40	PISTON, TILT CYLINDER -----	2
6511-41	COVER, TILT CYLINDER -----	2
6511-42	SLEEVE, TILT CYLINDER ROD GUIDE -----	2
6511-44	JOINT, PISTON ROD -----	2
6511-50	SEAL, GREASE -----	4
6511-5A	RING, HDLE SNAP -----	2
6511-5B	SEAL, DUST -----	2
6511-5C	RING, BACK UP -----	2
6511-5D	RING, O -----	2
6511-5E	RING, BACK UP -----	2
6511-5F	PACKING, U -----	2
6511-5G	PLATE, STOPPER -----	2
6511-5H	RING, HOLE SNAP -----	2
6511-5I	RING, O -----	2
6511-AJ	PACKING, U -----	4
6511-AK	SHIM, TILT CONTROL -----	99
6511-AL	SPACER, TILT CONTROL -----	2
6511-AM	RING, O -----	4
6511-AN	COLLAR -----	4
6511-AO	SPACER, TILT CONTROL -----	2
6511-AT	BOOT SUB-ASSY -----	2
6511-AU	BAR SUB-ASSY, TILT GAUGE -----	1
6511-AV	BRACKET SUB-ASSY, TILT GAUGE -----	1
6511-AW	PLATE, TILT CYLINDER INDICATOR -----	1

FIG. 6701 OIL PUMP

6701

V

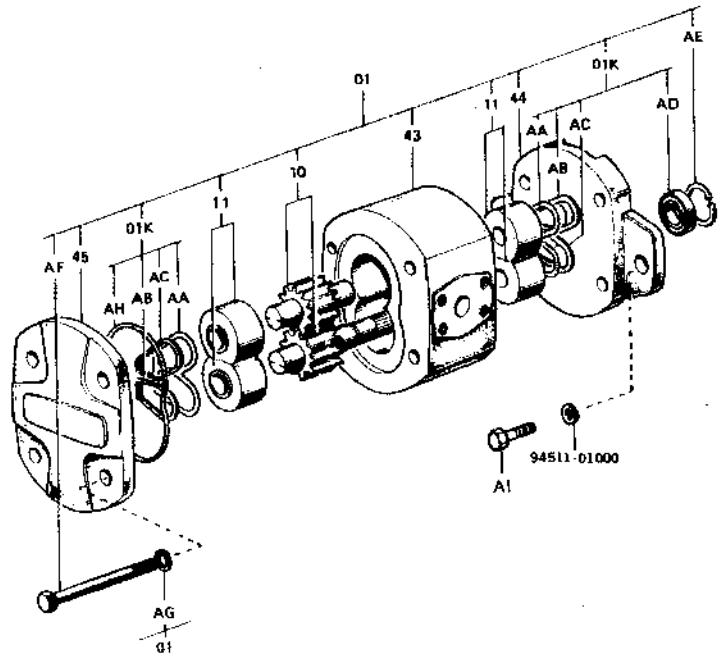

PART NAME CODE	PART NAME	QTY
6701-01	PUMP ASSY, OIL -----	1
6701-01K	PUMP O/H KIT, OIL -----	1
6701-10	GEAR SET -----	1
6701-11	BUSH SET, NO.1 -----	2
6701-43	BODY -----	1
6701-44	FLANGE, MOUNTING -----	1
6701-45	COVER -----	1
6701-AA	SEAL, BUSHING -----	2
6701-AB	RING, BACKING, RH -----	2
6701-AC	RING, BACKING, LH -----	2
6701-AD	SEAL, OIL -----	1
6701-AE	RING, SNAP -----	1
6701-AF	BOLT -----	4
6701-AG	WASHER, SPRING -----	4
6701-AH	SEAL, BODY -----	2
6701-AI	BOLT -----	2

6701-018

(V) (6)

G208

FIG. 6705 OIL CONTROL VALVE

6705

V (UL)

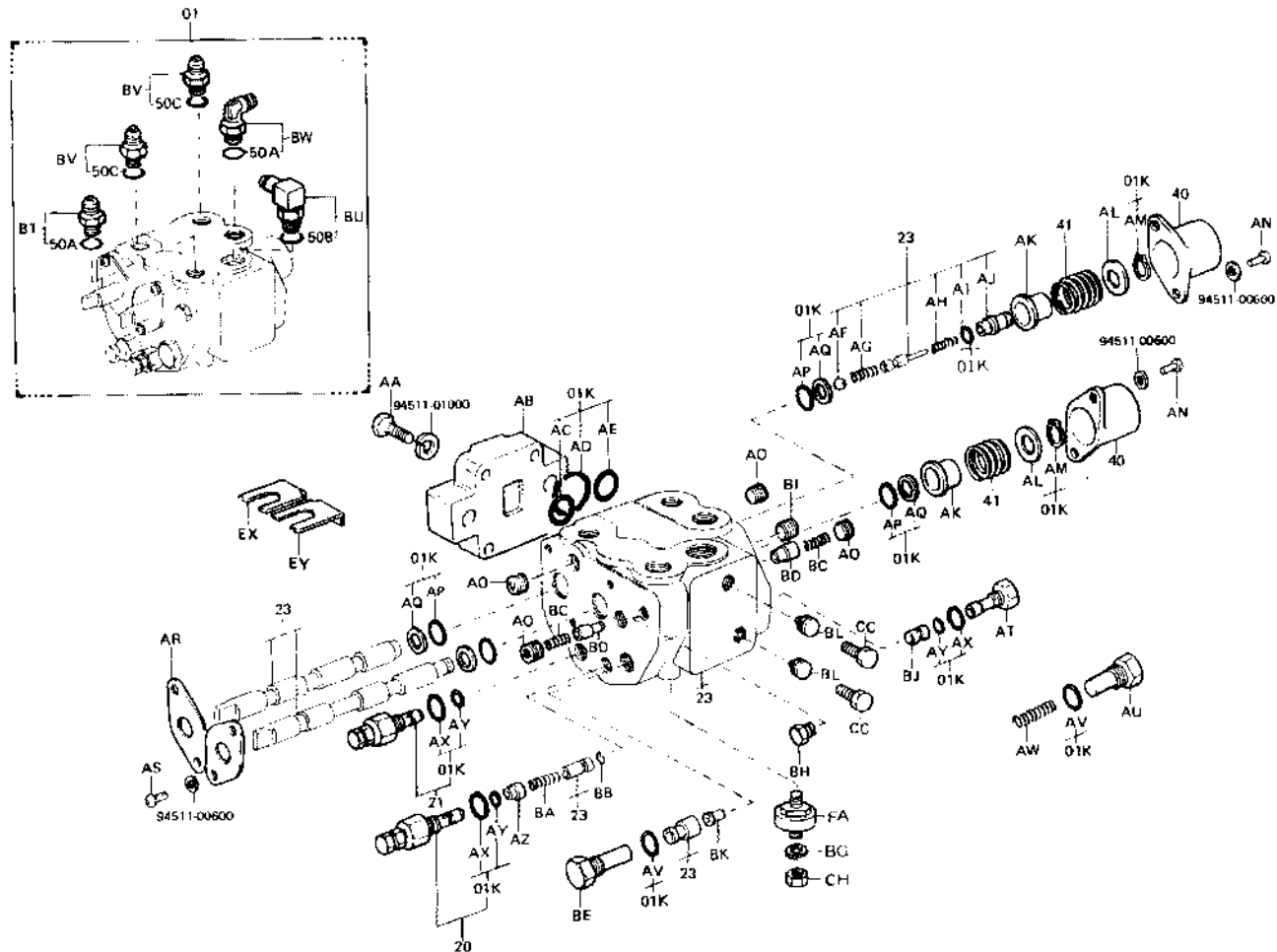





FIG. 6705 OIL CONTROL VALVE

6705

V (3-WAY..UL)

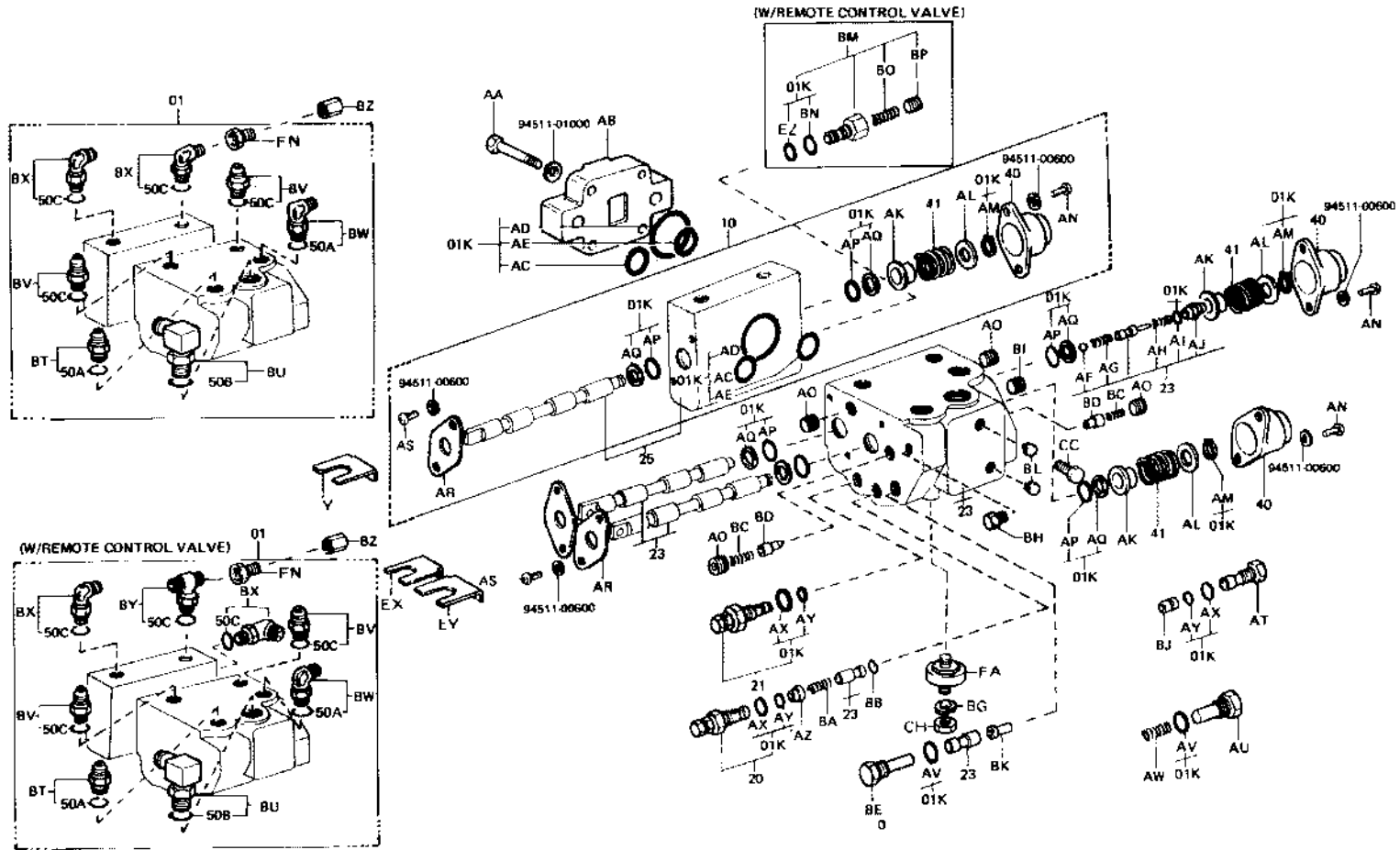

FIG. 6705 OIL CONTROL VALVE

# 6705

V (3-WAY)

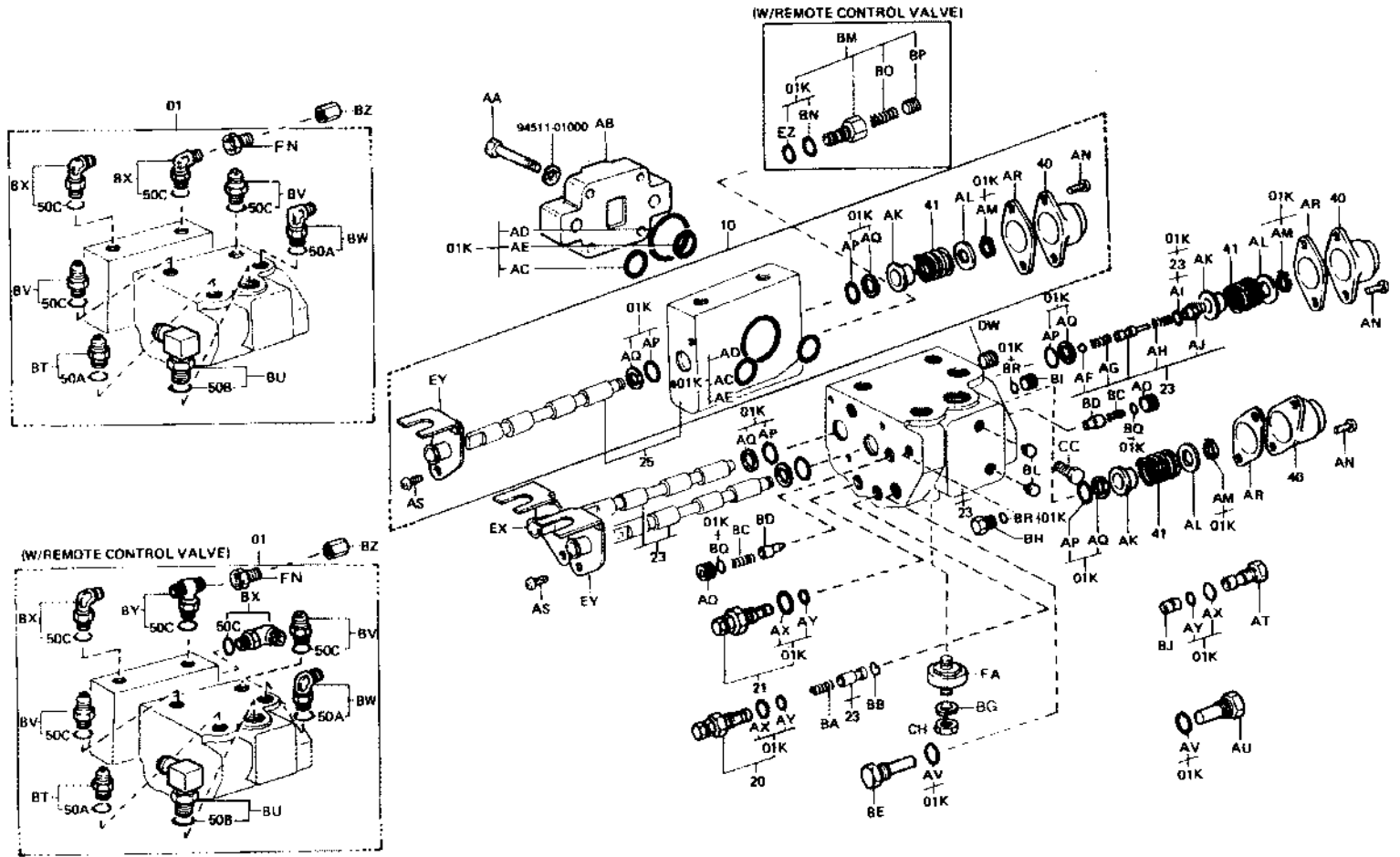
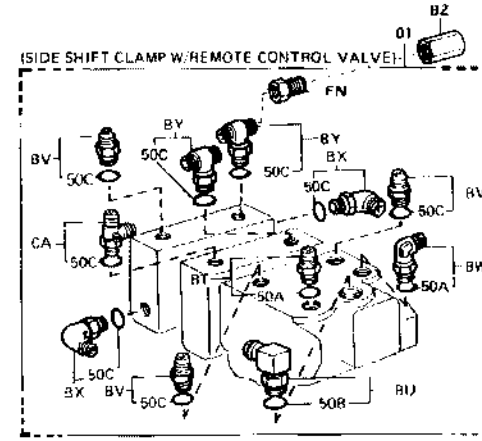
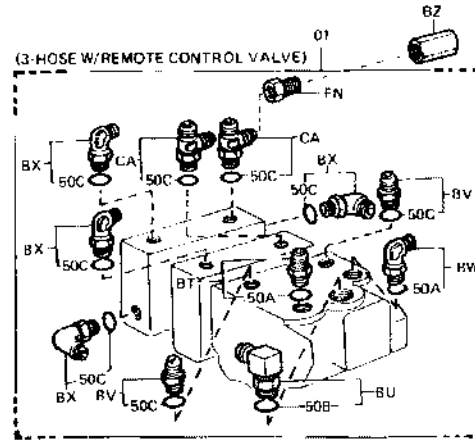
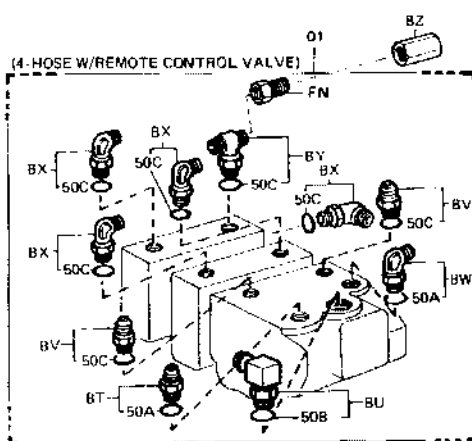
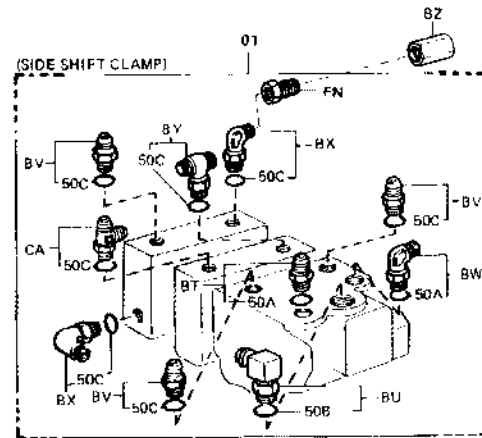
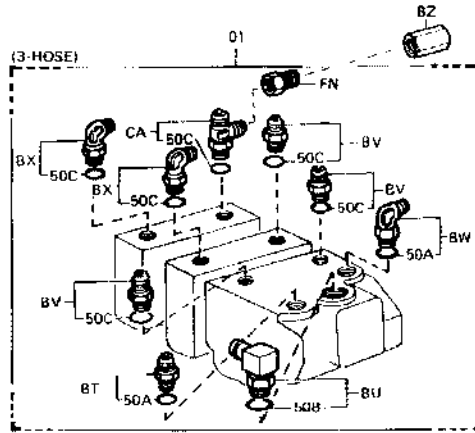
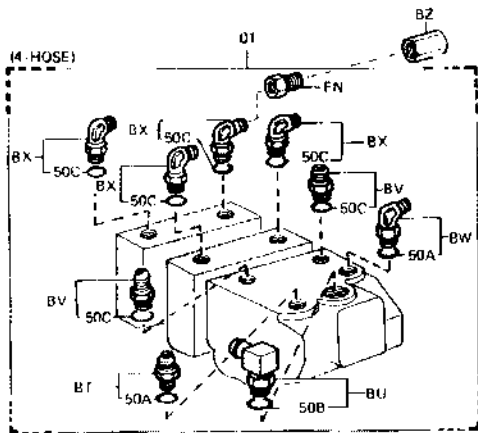

FIG. 6705 OIL CONTROL VALVE

6705

V (4-WAY)



6705 DM

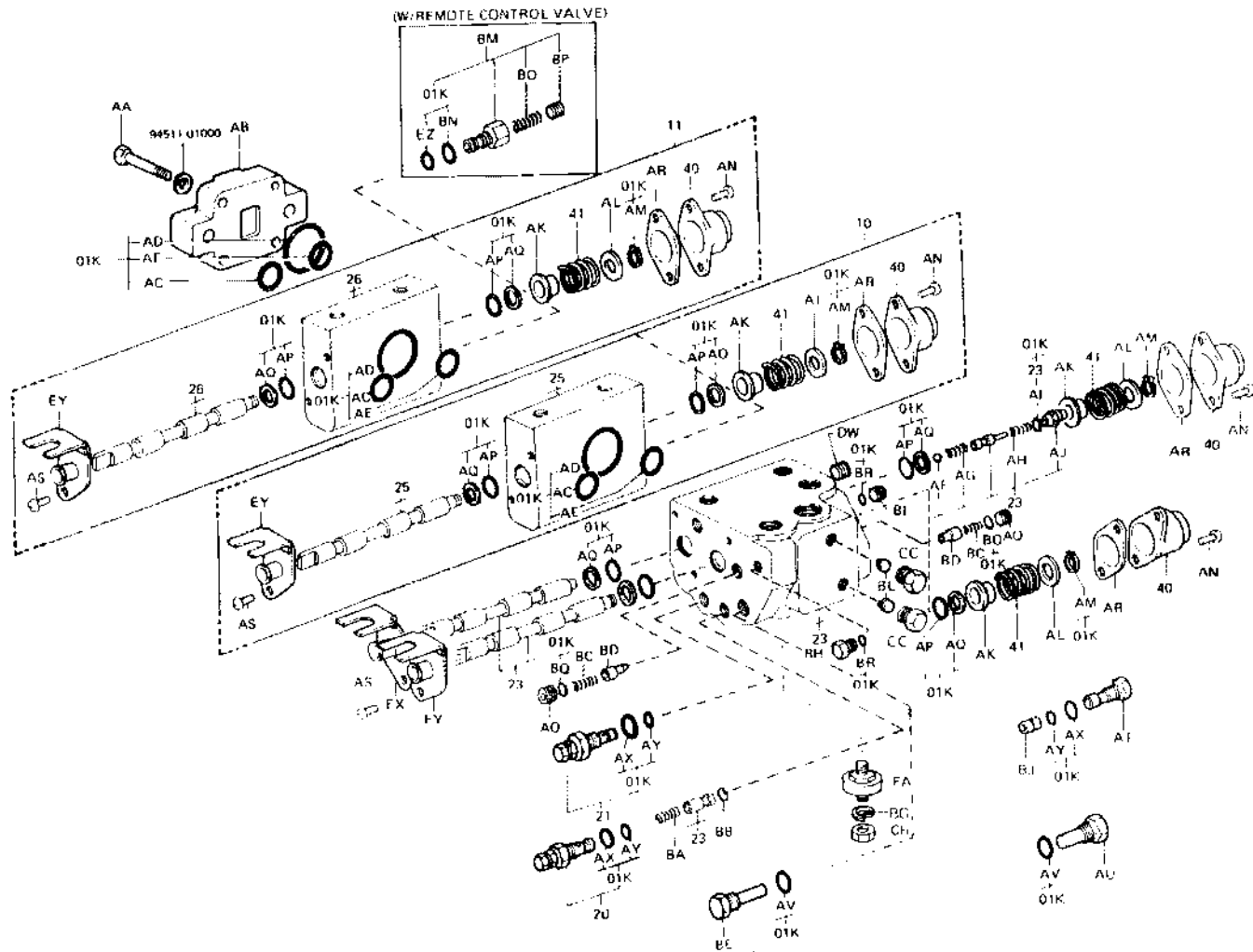



FIG. 6705 OIL CONTROL VALVE

6705

V (4-WAY)



6705 059

# 6705

PART NAME CODE	PART NAME	QTY
6705-01	VALVE ASSY, OIL CONTROL -----	1
6705-01K	VALVE O/H KIT, OIL CONTROL -----	1
6705-10	VALVE ASSY, PLUNGER SECTION, NO.1 -----	1
6705-11	VALVE ASSY, PLUNGER SECTION, NO.2 -----	1
6705-20	VALVE SET, PILOT RELIEF, NO.1 -----	1
6705-21	VALVE SET, PILOT RELIEF, NO.2 -----	1
6705-23	HOUSING & SPOOL SET, NO.1 -----	1
6705-25	HOUSING & SPOOL SET, ATTACHMENT, NO.1 -----	1
6705-26	HOUSING & SPOOL SET, ATTACHMENT, NO.2 -----	1
6705-40	COVER, SPRING -----	2
6705-41	SPRING, COMPRESSION (FOR SPOOL RETURN) -----	2
6705-50A	RING, O, NO.1 (FOR VALVE FITTING) -----	2
6705-50B	RING, O, NO.2 (FOR VALVE FITTING) -----	1
6705-50C	RING, O, NO.3 (FOR VALVE FITTING) -----	2
6705-AA	BOLT -----	4
6705-AB	HOUSING, OUTLET -----	1
6705-AC	RING, O -----	1
6705-AD	RING, O -----	1
6705-AE	RING, O -----	1
6705-AF	BALL, STEEL -----	1
6705-AG	SPRING -----	1
6705-AH	SPRING, COMPRESSION -----	1
6705-AI	RING, O -----	1
6705-AJ	STOPPER -----	1
6705-AK	HOLDER, SPRING -----	2
6705-AL	WASHER, PLATE -----	2
6705-AM	RING, SHAFT SNAP -----	2
6705-AN	SCREW -----	4
6705-AO	PLUG -----	2
6705-AP	RING, O -----	4
6705-AQ	RING, BACK UP -----	4
6705-AR	HOLDER, SEAL -----	2
6705-AS	SCREW -----	4
6705-AT	STOPPER -----	1
6705-AU	STOPPER -----	1
6705-AV	RING, O -----	2
6705-AW	SPRING, COMPRESSION -----	1
6705-AX	RING, O -----	3
6705-AY	RING, O -----	3
6705-AZ	COLLAR -----	1
6705-BA	SPRING, COMPRESSION -----	1
6705-BB	WIRE, ORIFICE TURNING -----	1
6705-BC	SPRING, COMPRESSION -----	2
6705-BD	PLUNGER, CHECK -----	2
6705-BE	STOPPER -----	1
6705-BG	WASHER -----	4
6705-BH	PLUG -----	1
6705-BI	PLUG -----	1
6705-BJ	SEAT, VALVE -----	1
6705-BK	VALVE, CHECK -----	1
6705-BL	SEAT, INSERT -----	2
6705-BM	VALVE SUB-ASSY, RELIEF -----	1
6705-BN	RING, O -----	1

( V ) ( 7 ) G208

PART NAME CODE	PART NAME	QTY
6705-BO	SPRING -----	1
6705-BP	STOPPER -----	1
6705-BQ	RING, O -----	2
6705-BR	RING, O -----	2
6705-BT	FITTING -----	1
6705-BU	FITTING -----	1
6705-BV	FITTING -----	2
6705-BW	FITTING -----	1
6705-BX	FITTING -----	2
6705-BY	FITTING -----	1
6705-BZ	PLUG -----	2
6705-CA	FITTING -----	1
6705-CC	PLUG -----	2
6705-CH	NUT -----	4
6705-DW	PLUG -----	1
6705-EX	BRACKET SUB-ASSY, TILT -----	1
6705-EY	BRACKET SUB-ASSY, LIFT -----	1
6705-EZ	RING, O -----	1
6705-FA	INSULATOR -----	4
6705-FN	FITTING -----	2

( V ) ( 8 ) G208

FIG. 6709 OIL CONTROL VALVE LINK

6709

V

V (3-WAY)

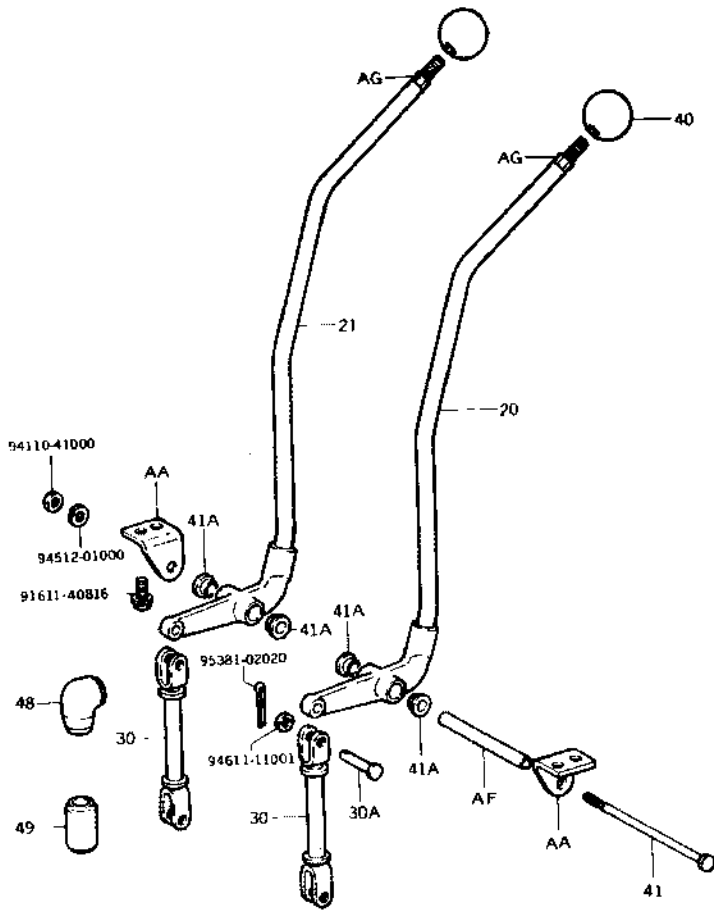

6709-016

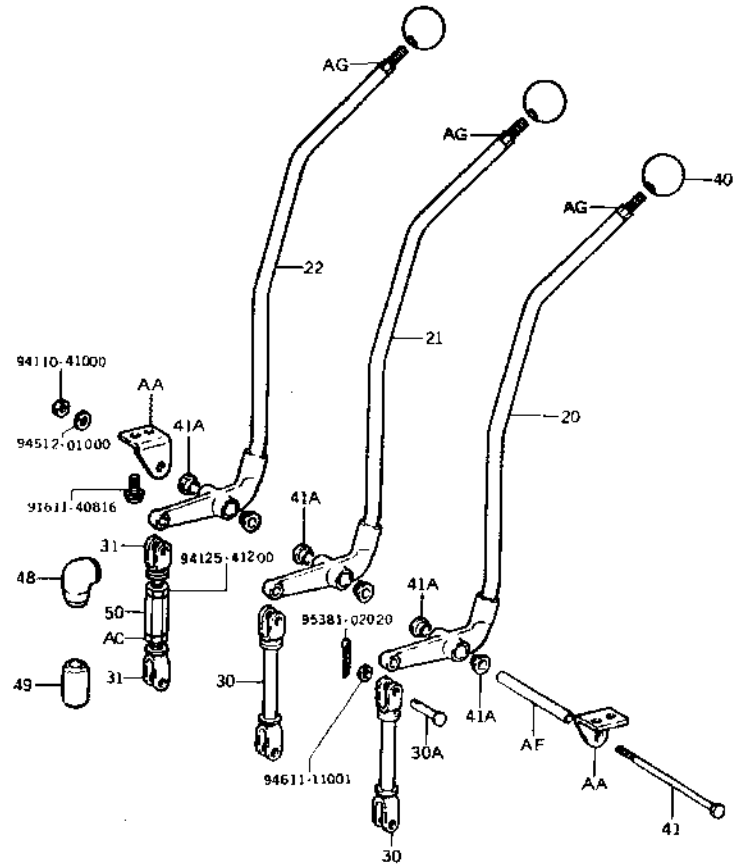

6709-017

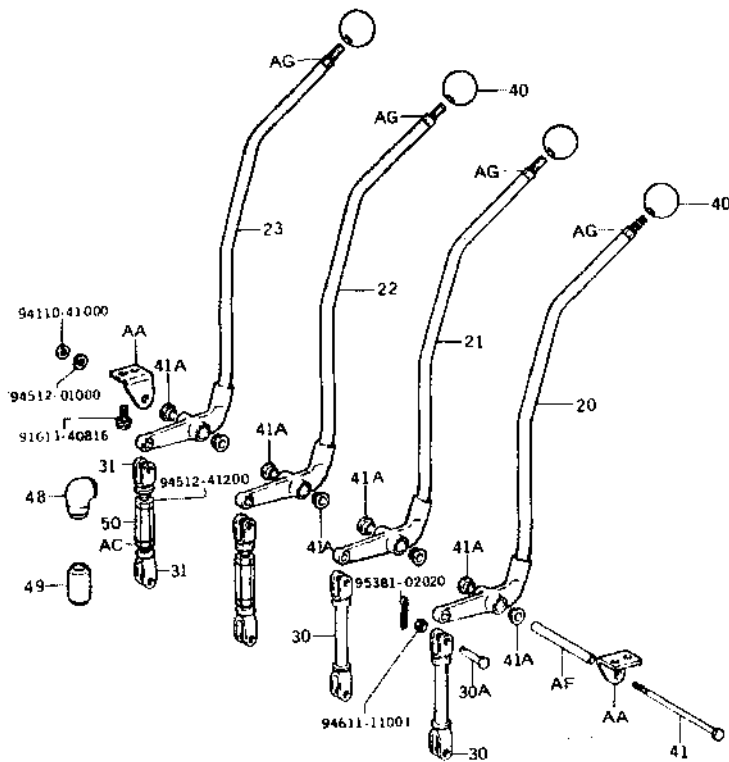



FIG. 6709 OIL CONTROL VALVE LINK

**6709**

V (4-WAY)



PART NAME CODE	PART NAME	QTY
6709-20	LEVER SUB-ASSY, CONTROL VALVE, NO.1 -----	1
6709-21	LEVER SUB-ASSY, CONTROL VALVE, NO.2 -----	1
6709-22	LEVER SUB-ASSY, CONTROL VALVE, NO.3 -----	1
6709-23	LEVER SUB-ASSY, CONTROL VALVE, NO.4 -----	1
6709-30	ROD SUB-ASSY, CONTROL VALVE LEVER, NO.1 ----	1
6709-30A	PIN (FGR CONTROL VALVE LEVER ROD) -----	4
6709-31	ROD SUB-ASSY, CONTROL VALVE LEVER, NO.2 ----	1
6709-40	KNOB, OIL CONTROL VALVE LEVER -----	2
6709-41	PIN, OIL CONTROL VALVE LEVER -----	1
6709-41A	BUSH (FOR LEVER PIN) -----	4
6709-48	BOOT, CONTROL VALVE LINK, NO.1 -----	2
6709-49	BOOT, CONTROL VALVE LINK, NO.2 -----	2
6709-50	TURNBUCKLE -----	1
6709-AA	BRACKET SUB-ASSY -----	1
6709-AC	NUT -----	1
6709-AF	SPACER -----	1
6709-AG	BOLT, STUD -----	2

FIG. 6801 BODY PIPING

6801

V

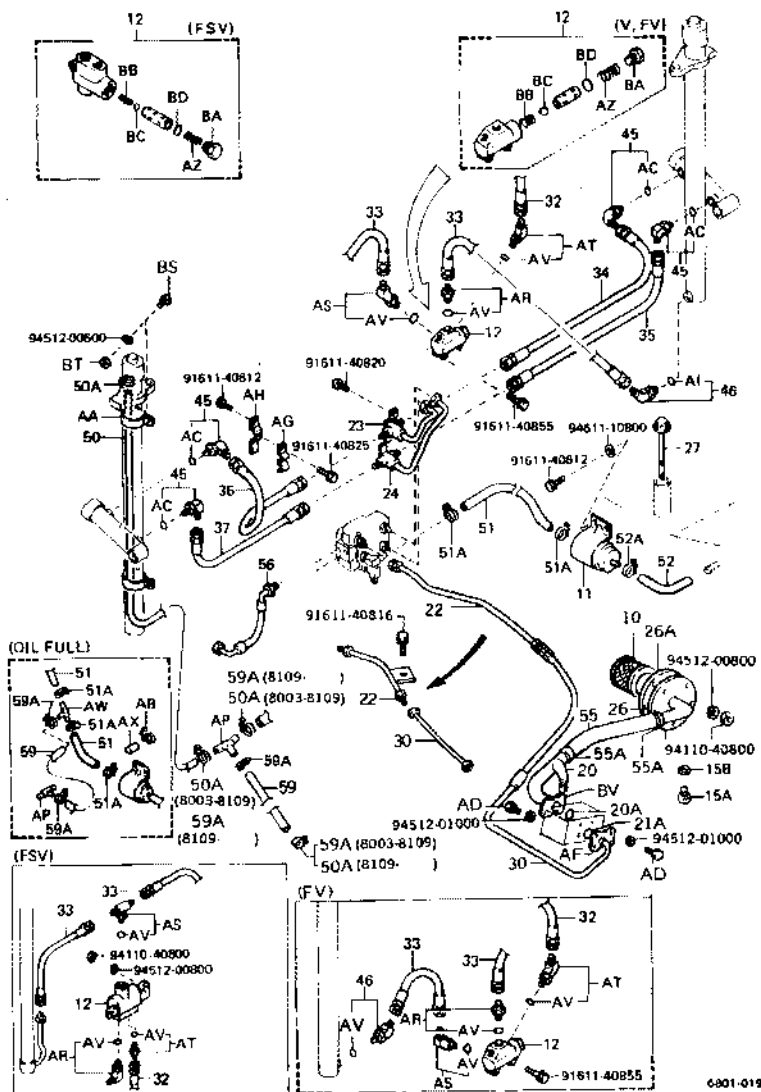

PART NAME CODE	PART NAME	QTY
6801-10	FILTER ASSY, SUCTION	1
6801-11	FILTER ASSY, RETURN	1
6801-12	VALVE ASSY, FLOW REGULATOR	1
6801-15A	PLUG (FOR OIL TANK DRAIN)	1
6801-15B	GASKET (FOR OIL TANK DRAIN PLUG)	1
6801-20	PIPE SUB-ASSY (PUMP INLET)	1
6801-20A	RING, O (FOR OIL PUMP INLET)	1
6801-21A	RING, O (FOR OIL PUMP OUTLET)	1
6801-22	PIPE SUB-ASSY (PUMP TO VALVE)	1
6801-23	PIPE SUB-ASSY (TILT CYLINDER FRONT)	1
6801-24	PIPE SUB-ASSY (TILT CYLINDER REAR)	1
6801-26	OUTLET SUB-ASSY, OIL TANK	1
6801-26A	PACKING, OIL TANK COVER	1
6801-27	CAP SUB-ASSY, OIL TANK	1
6801-30	HOSE, HIGH PRESSURE, NO.1 (PUMP TO VALVE)	1
6801-32	HOSE, HIGH PRESSURE, NO.1 (VALVE TO LIFT)	1
6801-33	HOSE, HIGH PRESSURE, NO.2 (VALVE TO LIFT)	2
6801-34	HOSE, HIGH PRESSURE, NO.1 (TILT FRONT)	1
6801-35	HOSE, HIGH PRESSURE, NO.1 (TILT REAR)	1
6801-36	HOSE, HIGH PRESSURE, NO.2 (TILT FRONT)	1
6801-37	HOSE, HIGH PRESSURE, NO.2 (TILT REAR)	1
6801-45	FITTING (FOR TILT CYLINDER)	2
6801-46	FITTING (FOR LIFT CYLINDER)	2
6801-50	HOSE, LOW PRESSURE, NO.1 (LIFT TO TANK)	2
6801-50A	CLAMP (FOR LIFT TO TANK NO.1 HOSE)	3- 4
6801-51	HOSE, LOW PRESSURE, NO.1 (VALVE TO TANK)	1
6801-51A	CLAMP (FOR VALVE TO TANK NO.1 HOSE)	2
6801-52	HOSE, LOW PRESSURE, NO.2 (VALVE TO TANK)	1
6801-52A	CLAMP (FOR VALVE TO TANK NO.2 HOSE)	2
6801-55	HOSE, LOW PRESSURE (TANK TO PUMP)	1
6801-55A	CLAMP (FOR TANK TO PUMP HOSE)	2
6801-56	HOSE, LOW PRESSURE (STEERING TO VALVE)	1
6801-59	HOSE, LOW PRESSURE, NO.2 (LIFT TO TANK)	1
6801-59A	CLAMP (FOR LIFT TO TANK NO.2 HOSE)	2- 3
6801-AA	BAND, LIFT CYLINDER OVERFLOW HOSE	4
6801-AB	CLAMP	1
6801-AC	RING, O	4
6801-AD	BOLT	8
6801-AF	FLANGE, SPLIT	1
6801-AG	CLAMP	1
6801-AH	BRACKFT SUB-ASSY, TILT HOSE	1
6801-AI	RING, O	2
6801-AP	PIPE	1
6801-AR	FITTING	1
6801-AS	FITTING	1
6801-AT	FITTING	1
6801-AV	RING, O	3
6801-AW	ELBOW SUB-ASSY, 3-WAY	1
6801-AX	CAP, OIL TANK OVERFLOW PIPE	1
6801-AZ	SPRING, COMPRESSION	1
6801-BA	PLUG	1
6801-BB	SPRING, COMPRESSION	1
6801-BC	BALL, STEEL	1

(V) (10)

G208

**6801**

PART NAME CODE	PART NAME	QTY
6801-BD	RING, O -----	1
6801-BS	BOLT -----	5
6801-BT	WASHER -----	5
6801-BV	FLANGE -----	2

(V ) ( 11)

G208